

Alkaline Battery

Type Designation ANSI:	D	
Designation IEC:	LR20	
System:	Electrolyte-zinc-manganese dioxide (mercury & cadmium free)	
Nominal Voltage (V):	1.5	
Typical Capacity (mAh):	14,800	
Operating Temperature (°C):	-20 to +54	
Storage Temperature (°C):	-20 to +35	
Dimensions (mm):	min.	max.
H Height (mm):	59.5	61.5
D Diameter Ø (mm):	32.3	34.2
Weight (g):	≤	145.0
Storing temperature (°C):	20±2	
Storing Humidity (%):	60±5	

Figure:



Drawing:

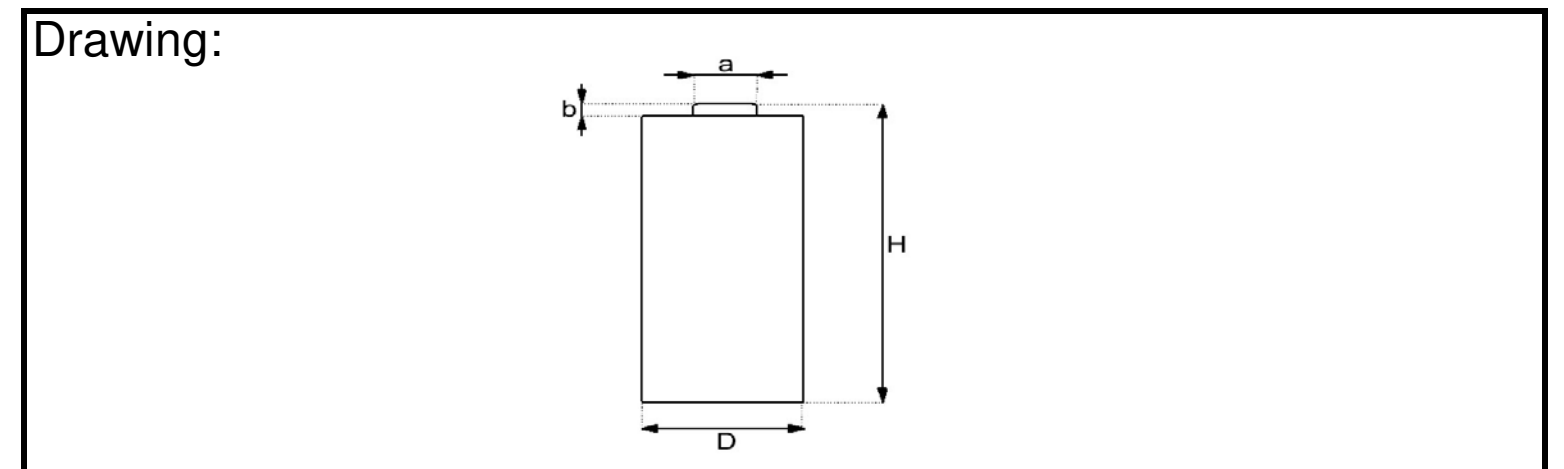

Discharge Characteristics

Discharge test (service life) (Test environment: 20°C±2,45%--75%R.H)

Load	2.2 Ω	3.9 Ω	10 Ω
Discharge mode	1h/day	1h/day	4hrs/day
End voltage	0.8V	0.9V	0.9V
Initial	20h	38h	118h
After 12 months storage	18.5h	34.5h	110h

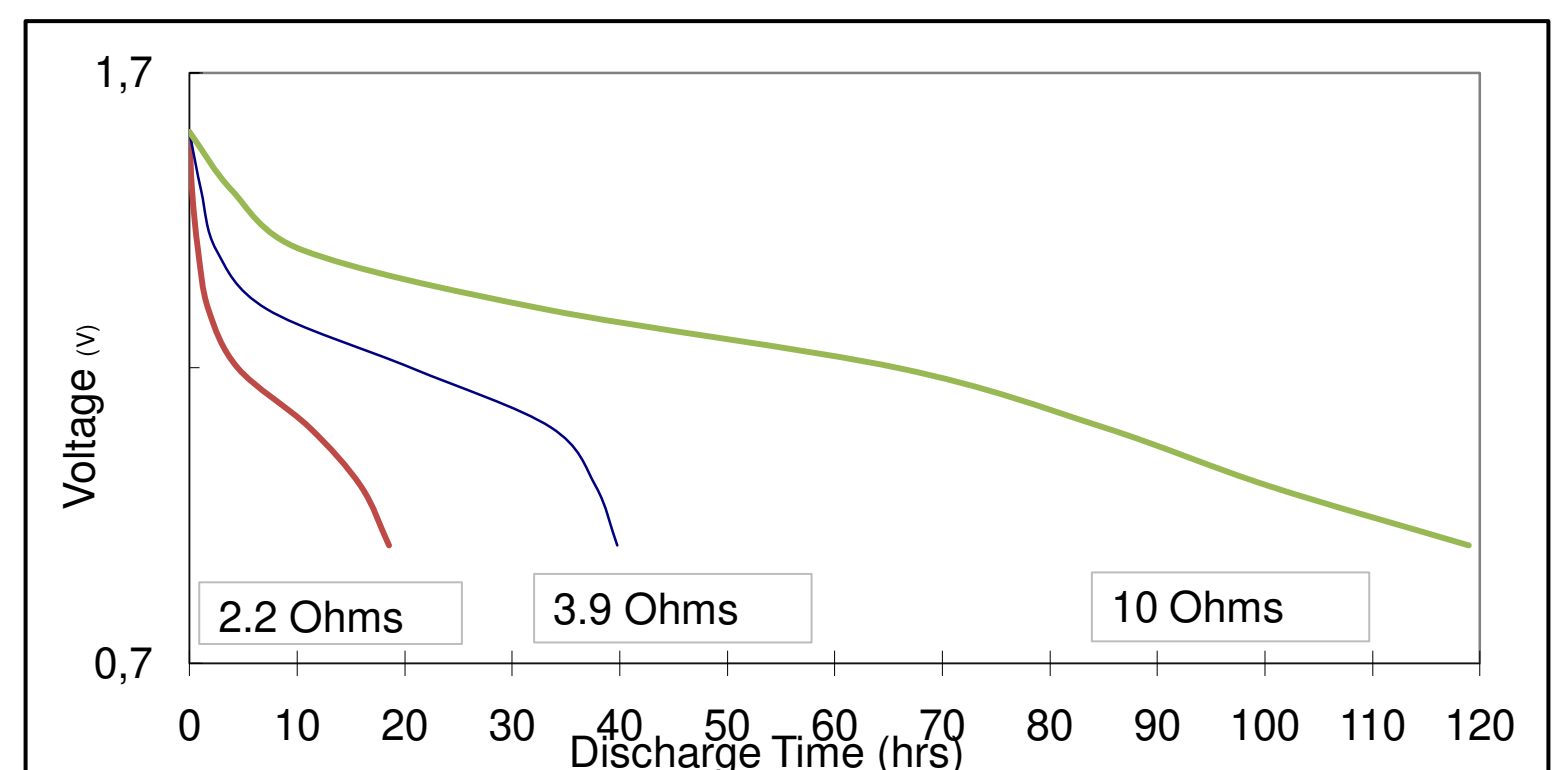

Test environment: 20°C±2,60%±15%R.H, Load resistance: 3.9 ohms, Measure time: 0.3s

	OCV (V)	CCV (V)	SCC (A)
Initial	≥1.59	≥1.50	≥10
After 12 months storage	≥1.57	≥1.45	≥8

Remark: OCV: Open Circuit Voltage; CCV: Close Circuit Voltage; SCC: Short Circuit Current

Heavy Metal content (%):

Material	Mercury	Cadmium	Lead
Content	≤1ppm	≤10ppm	≤40ppm

Safety Instructions

- ▶ Keep batteries safely away from children!
- ▶ Do not charge, short-circuit, stab, deform, or otherwise damage batteries!
- ▶ Do not heat up batteries or expose them to fire or temperatures in excess of 85°C!
- ▶ Never disassemble and do not mix batteries with other battery types!
- ▶ Never expose batteries to water!
- ▶ Avoid short-circuiting the battery terminals!
- ▶ Store batteries in cool and dry ambiances lower than 30°C at a constant temperature.
- ▶ Avoid placing or storing batteries next to heaters and avoid direct sun light.
- ▶ There's a risk of bursting if heated up in excess of 100°C or by overcharging them.
- ▶ According to IATA Regulations, tecXus™ batteries are not considered dangerous goods.
- ▶ Remove batteries when not in use for longer periods.
- ▶ The safety regulation IEC 60086-5 contains additional recommendations for producers and users.

Disposal Instructions

Batteries must not be disposed with household waste. Its components must be recycled or disposed separately from each other. Otherwise contaminative and hazardous substances may pollute the environment.

You as a consumer are committed by law to return batteries to the producer, the dealer, or public collecting points at the end of its lifetime, free of charge. Particulars are regulated according to national right. The symbol on the product, in the user's manual, or at the packing refers to these regulations. With this kind of waste separation, application, and waste disposal of used batteries an important contribution can be made to environmental protection.

2006/66/EC

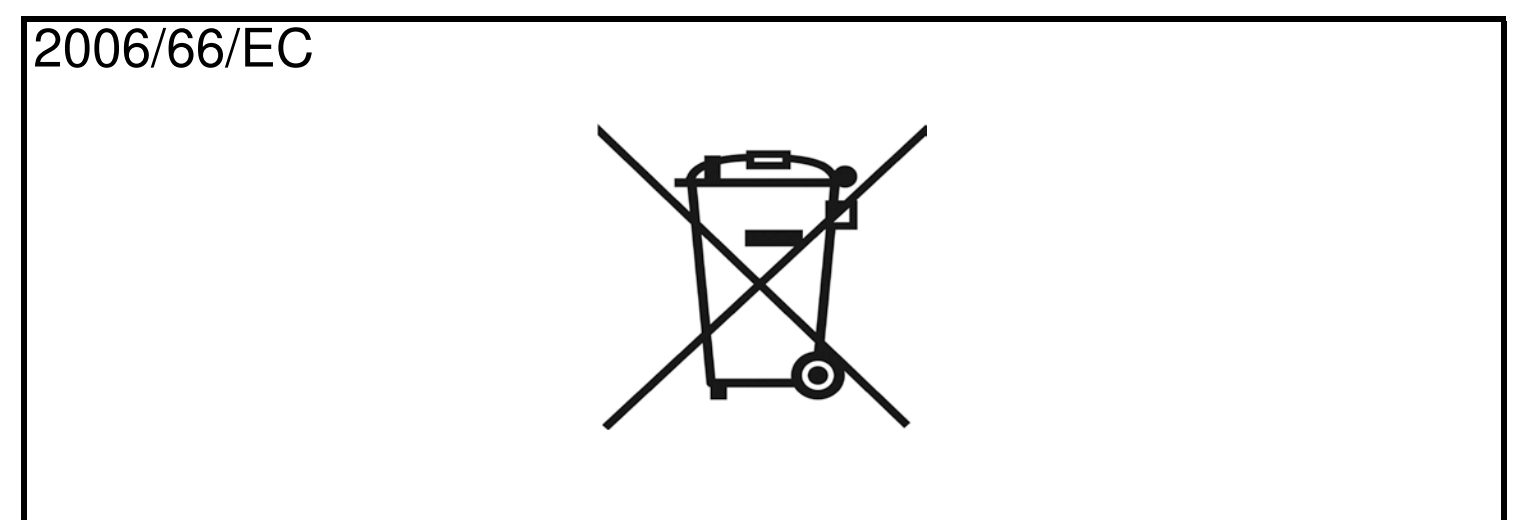

Delivered capacity is dependent on the applied load, operating and cut-off voltage. Referring to the charts and discharge data shown for examples of the energy / service life that the battery will provide for various load conditions.