

REVISION RECORD				
REV	ECN	DESCRIPTION	DRFT	DATE

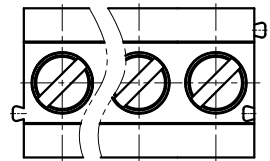

NOTES1:

UL Standard

- 1.Rated voltage/current : 300V / 7A
- 2.Torque Value : M2 , 1.77Lb.in
- 3.Wire range : 24~18AWG

IEC Standard

- 1.Rated voltage/current : 130V / 10A
- 2.Torque Value : M2 , 0.2N.m
- 3.Wire range : 0.5~1.0mm²

NOTES2:

- 1.Dimension shall be interpreted per ASME Y14.5-2009
- 2.Pitch : 3.5/3.96mm, Poles : N=02~24P
- 3.Stripping length : 5mm
- 4.Withstanding voltage : AC1250V/1Min
- 5.Operating temperature: -40°C~+105°C
- 6.Undimensioned tolerances:

Pitch range in mm		Nominal dimension range in mm				-	∩	□
TO	Over	Over	Over	Over	Over	0.1/10	∩	□
6	6 TO 10	10 TO 24	30 TO 60	60 TO 100	100 TO 150			
±0.15	±0.20	±0.30	±0.30	±0.50	±0.70	±1.00	±1.30	±2'

7.RoHS Compliance

DG350 - 3.5/3.96 - XXP - 1Y - 00A (H)

(Series No.) (Pitch) (Poles) (Single Pitch) (Color):1.(Grey)
 2.(Blue)
 3.(Black)
 4.(Green)
 5.(Orange)
 6.(Red)
 7.(Transparent)
 8.(Yellow)
 9.(White)

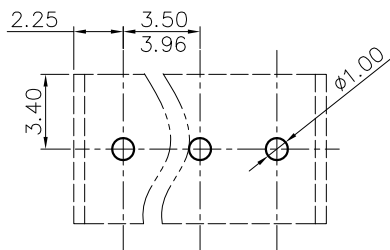
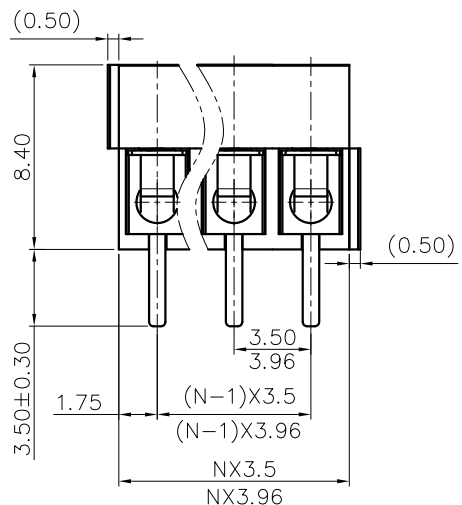
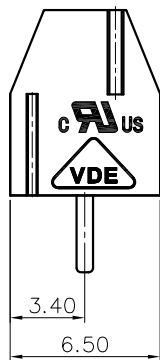

PCB LAYOUT

DETACHED LISTS	PART NO.:	NINGBO DEGSON ELECTRICAL CO., LTD			
	APPD:	NAME: DG350-3.5/3.96-XXP-1Y-00A(H)			
	CHKD:	TITLE: CUSTOMER DRAWING		REV	DO
	DRFT:	DRAWING NO.:		SHEET	1/1
THIRD ANGLE PROJECTION		MM (INCH)	DO NOT SCALE DRAWING	SCALE	1:1