

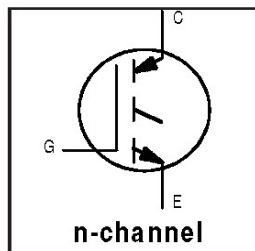
# IRG4PH30KPbF

## INSULATED GATE BIPOLAR TRANSISTOR

## Short Circuit Rated UltraFast IGBT

### Features

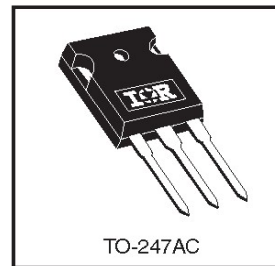
- High short circuit rating optimized for motor control,  $t_{sc} = 10\mu s$ ,  $V_{CC} = 720V$ ,  $T_J = 125^\circ C$ ,  $V_{GE} = 15V$
- Combines low conduction losses with high switching speed
- Latest generation design provides tighter parameter distribution and higher efficiency than previous generations
- Lead-Free



|                             |
|-----------------------------|
| $V_{CES} = 1200V$           |
| $V_{CE(on) typ.} = 3.10V$   |
| @ $V_{GE} = 15V, I_C = 10A$ |

### Benefits

- As a Freewheeling Diode we recommend our HEXFRED™ ultrafast, ultrasoft recovery diodes for minimum EMI / Noise and switching losses in the Diode and IGBT
- Latest generation 4 IGBT's offer highest power density motor controls possible
- This part replaces the IRGPH30K and IRGPH30M devices



### Absolute Maximum Ratings

|                           | Parameter                          | Max.                              | Units      |
|---------------------------|------------------------------------|-----------------------------------|------------|
| $V_{CES}$                 | Collector-to-Emitter Voltage       | 1200                              | V          |
| $I_C @ T_C = 25^\circ C$  | Continuous Collector Current       | 20                                | A          |
| $I_C @ T_C = 100^\circ C$ | Continuous Collector Current       | 10                                |            |
| $I_{CM}$                  | Pulsed Collector Current ①         | 40                                |            |
| $I_{LM}$                  | Clamped Inductive Load Current ②   | 40                                |            |
| $t_{sc}$                  | Short Circuit Withstand Time       | 10                                | $\mu s$    |
| $V_{GE}$                  | Gate-to-Emitter Voltage            | $\pm 20$                          | V          |
| $E_{ARV}$                 | Reverse Voltage Avalanche Energy ③ | 121                               | mJ         |
| $P_D @ T_C = 25^\circ C$  | Maximum Power Dissipation          | 100                               | W          |
| $P_D @ T_C = 100^\circ C$ | Maximum Power Dissipation          | 42                                |            |
| $T_J$                     | Operating Junction and             | -55 to +150                       | $^\circ C$ |
| $T_{STG}$                 | Storage Temperature Range          |                                   |            |
|                           | Soldering Temperature, for 10 sec. | 300 (0.063 in. (1.6mm) from case) |            |
|                           | Mounting torque, 6-32 or M3 screw. | 10 lbf•in (1.1N•m)                |            |

### Thermal Resistance

|                 | Parameter                                 | Typ.     | Max. | Units        |
|-----------------|---|----------|------|--------------|
| $R_{\theta JC}$ | Junction-to-Case                          | —        | 1.2  | $^\circ C/W$ |
| $R_{\theta CS}$ | Case-to-Sink, Flat, Greased Surface       | 0.24     | —    |              |
| $R_{\theta JA}$ | Junction-to-Ambient, typical socket mount | —        | 40   |              |
| $Wt$            | Weight                                    | 6 (0.21) | —    | g (oz)       |

## Electrical Characteristics @ $T_J = 25^\circ\text{C}$ (unless otherwise specified)

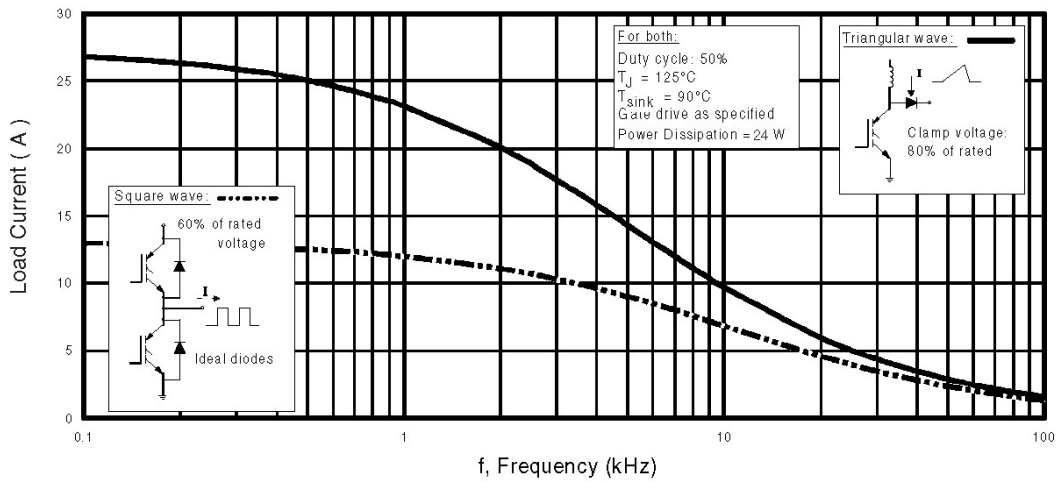
|                                 | Parameter                                | Min. | Typ. | Max.      | Units   | Conditions   |
|---------------------------------|--|------|------|-----------|---------|--|
| $V_{(BR)CES}$                   | Collector-to-Emitter Breakdown Voltage   | 1200 | —    | —         | V       | $V_{GE} = 0V, I_C = 250\mu A$                          |
| $V_{(BR)ECS}$                   | Emitter-to-Collector Breakdown Voltage ④ | 18   | —    | —         | V       | $V_{GE} = 0V, I_C = 1.0A$                              |
| $\Delta V_{(BR)CES}/\Delta T_J$ | Temperature Coeff. of Breakdown Voltage  | —    | 0.19 | —         | V/°C    | $V_{GE} = 0V, I_C = 2.0mA$                             |
| $V_{CE(ON)}$                    | Collector-to-Emitter Saturation Voltage  | —    | 3.10 | 4.2       | V       | $I_C = 10A, V_{GE} = 15V$<br>See Fig.2, 5              |
|                                 |  | —    | 3.90 | —         |         |  |
|                                 |  | —    | 3.01 | —         |         |  |
| $V_{GE(th)}$                    | Gate Threshold Voltage                   | 3.0  | —    | 6.0       |         | $V_{CE} = V_{GE}, I_C = 250\mu A$                      |
| $\Delta V_{GE(th)}/\Delta T_J$  | Temperature Coeff. of Threshold Voltage  | —    | -12  | —         | mV/°C   | $V_{CE} = V_{GE}, I_C = 250\mu A$                      |
| $g_{fe}$                        | Forward Transconductance ⑤               | 4.3  | 6.5  | —         | S       | $V_{CE} = 100V, I_C = 10A$                             |
| $I_{CES}$                       | Zero Gate Voltage Collector Current      | —    | —    | 250       | $\mu A$ | $V_{GE} = 0V, V_{CE} = 1200V$                          |
|                                 |  | —    | —    | 2.0       |         | $V_{GE} = 0V, V_{CE} = 10V, T_J = 25^\circ\text{C}$    |
|                                 |  | —    | —    | 2000      |         | $V_{GE} = 0V, V_{CE} = 1200V, T_J = 150^\circ\text{C}$ |
| $I_{GES}$                       | Gate-to-Emitter Leakage Current          | —    | —    | $\pm 100$ | nA      | $V_{GE} = \pm 20V$                                     |

## Switching Characteristics @ $T_J = 25^\circ\text{C}$ (unless otherwise specified)

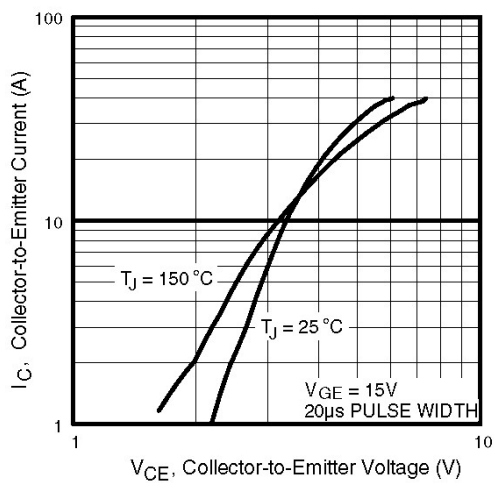
|              | Parameter                         | Min. | Typ. | Max. | Units   | Conditions   |
|--------------|-----------------------------------|------|------|------|---------|--|
| $Q_g$        | Total Gate Charge (turn-on)       | —    | 53   | 80   | nC      | $I_C = 10A$<br>$V_{CC} = 400V$ See Fig.8<br>$V_{GE} = 15V$   |
| $Q_{ge}$     | Gate - Emitter Charge (turn-on)   | —    | 9.0  | 14   |         |  |
| $Q_{gc}$     | Gate - Collector Charge (turn-on) | —    | 21   | 32   |         |  |
| $t_{d(on)}$  | Turn-On Delay Time                | —    | 28   | —    | ns      | $T_J = 25^\circ\text{C}$<br>$I_C = 10A, V_{CC} = 960V$<br>$V_{GE} = 15V, R_G = 23\Omega$                                   |
| $t_r$        | Rise Time                         | —    | 23   | —    |         |  |
| $t_{d(off)}$ | Turn-Off Delay Time               | —    | 200  | 300  |         |  |
| $t_f$        | Fall Time                         | —    | 110  | 170  |         |  |
| $E_{on}$     | Turn-On Switching Loss            | —    | 0.64 | —    | mJ      | Energy losses include "tail"<br>See Fig. 9,10,14   |
| $E_{off}$    | Turn-Off Switching Loss           | —    | 0.92 | —    |         |  |
| $E_{ts}$     | Total Switching Loss              | —    | 1.56 | 2.4  |         |  |
| $t_{sc}$     | Short Circuit Withstand Time      | 10   | —    | —    | $\mu s$ | $V_{CC} = 720V, T_J = 125^\circ\text{C}$<br>$V_{GE} = 15V, R_G = 23\Omega$   |
| $t_{d(on)}$  | Turn-On Delay Time                | —    | 27   | —    | ns      | $T_J = 150^\circ\text{C},$<br>$I_C = 10A, V_{CC} = 960V$<br>$V_{GE} = 15V, R_G = 23\Omega$<br>Energy losses include "tail" |
| $t_r$        | Rise Time                         | —    | 26   | —    |         |  |
| $t_{d(off)}$ | Turn-Off Delay Time               | —    | 310  | —    |         |  |
| $t_f$        | Fall Time                         | —    | 330  | —    |         |  |
| $E_{ts}$     | Total Switching Loss              | —    | 3.18 | —    | mJ      | See Fig. 10,11,14  |
| $L_E$        | Internal Emitter Inductance       | —    | 13   | —    | nH      | Measured 5mm from package  |
| $C_{res}$    | Input Capacitance                 | —    | 800  | —    | pF      | $V_{GE} = 0V$<br>$V_{CC} = 30V$ See Fig. 7<br>$f = 1.0MHz$   |
| $C_{oes}$    | Output Capacitance                | —    | 60   | —    |         |  |
| $C_{res}$    | Reverse Transfer Capacitance      | —    | 14   | —    |         |  |

### Notes:

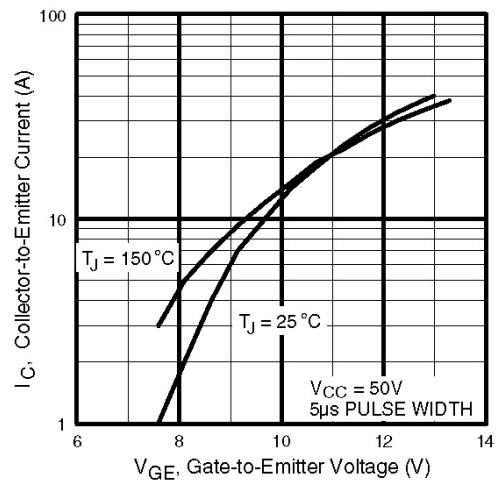
- ① Repetitive rating;  $V_{GE} = 20V$ , pulse width limited by max. junction temperature. ( See fig. 13b )
- ②  $V_{CC} = 80\%(V_{CES}), V_{GE} = 20V, L = 10\mu H, R_G = 23\Omega$ , (See fig. 13a)
- ③ Repetitive rating; pulse width limited by maximum junction temperature.
- ④ Pulse width  $\leq 80\mu s$ ; duty factor  $\leq 0.1\%$ .
- ⑤ Pulse width  $5.0\mu s$ , single shot.



**Fig. 1** - Typical Load Current vs. Frequency  
(Load Current =  $I_{\text{RMS}}$  of fundamental)



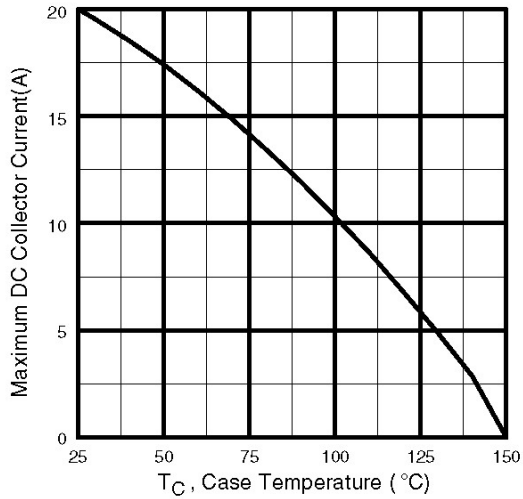
**Fig. 2** - Typical Output Characteristics



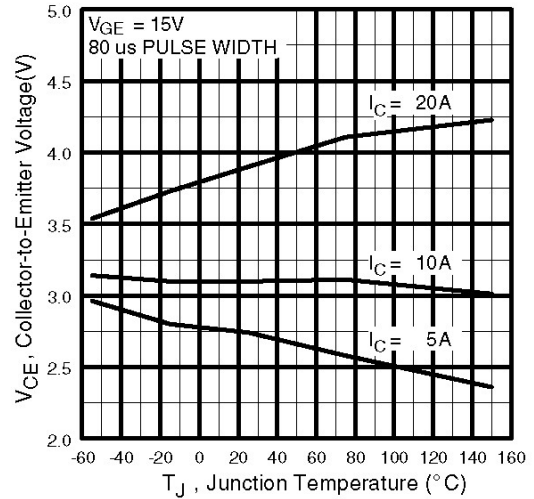
**Fig. 3** - Typical Transfer Characteristics

# IRG4PH30KPbF

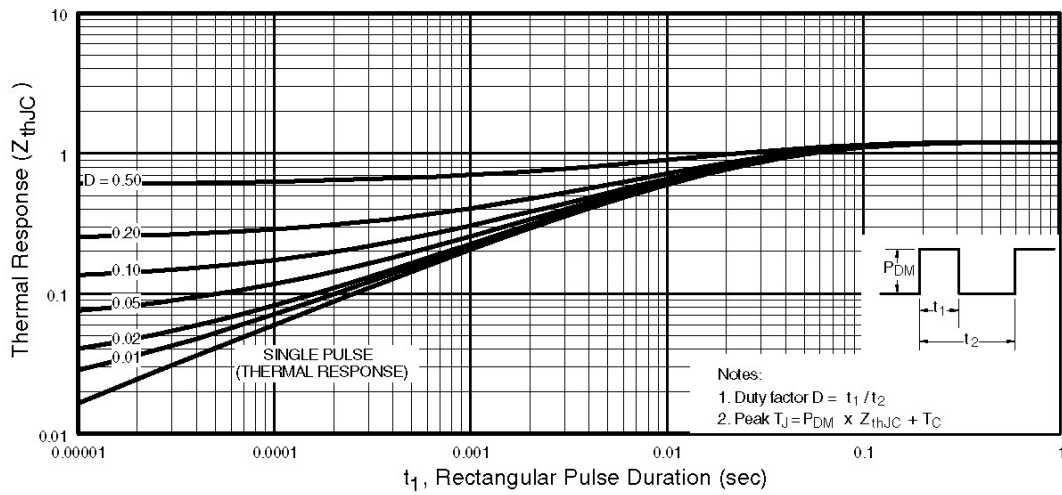
International  
**IR** Rectifier



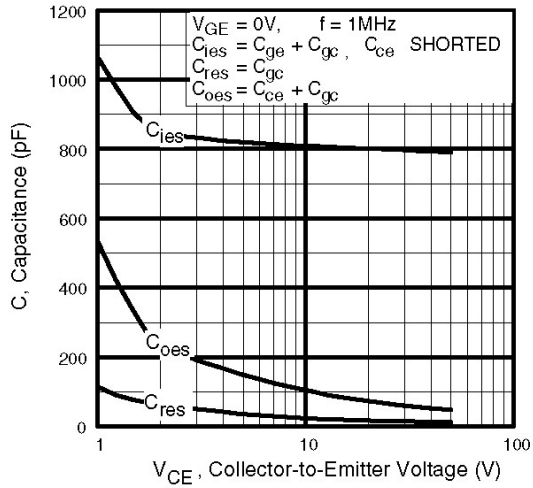
**Fig. 4** - Maximum Collector Current vs. Case Temperature



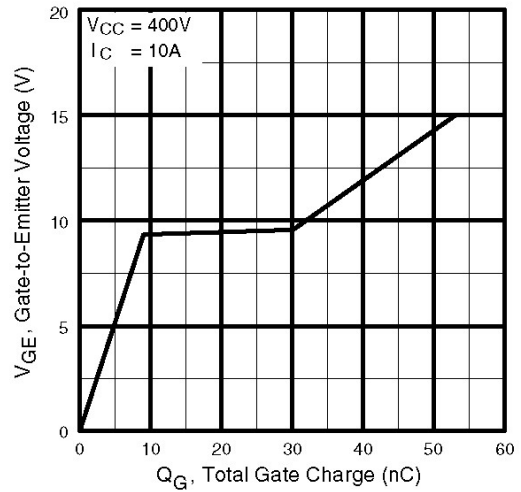
**Fig. 5** - Typical Collector-to-Emitter Voltage vs. Junction Temperature



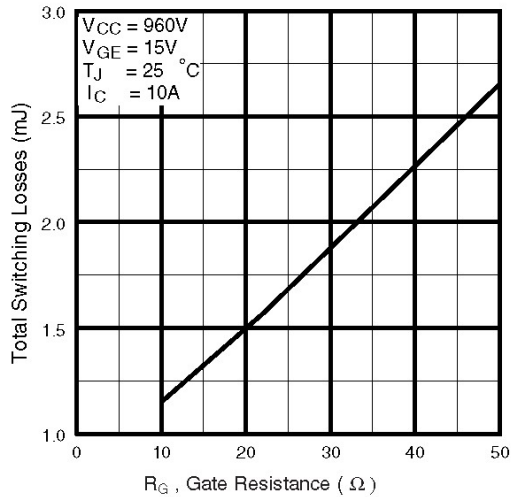
**Fig. 6** - Maximum Effective Transient Thermal Impedance, Junction-to-Case



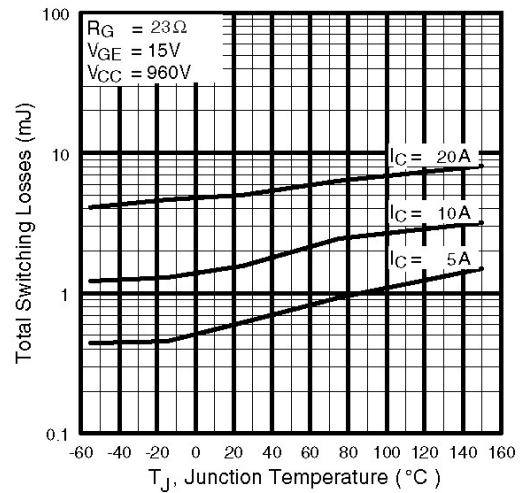
**Fig. 7** - Typical Capacitance vs. Collector-to-Emitter Voltage



**Fig. 8** - Typical Gate Charge vs. Gate-to-Emitter Voltage

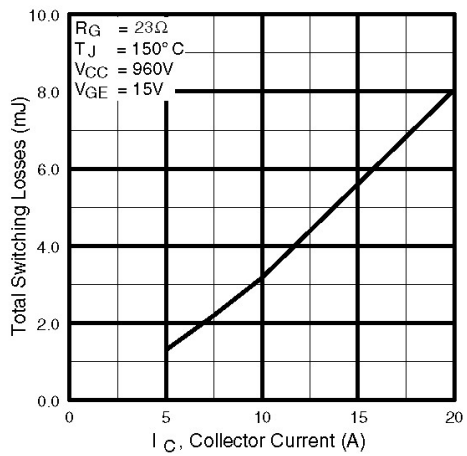


**Fig. 9** - Typical Switching Losses vs. Gate Resistance

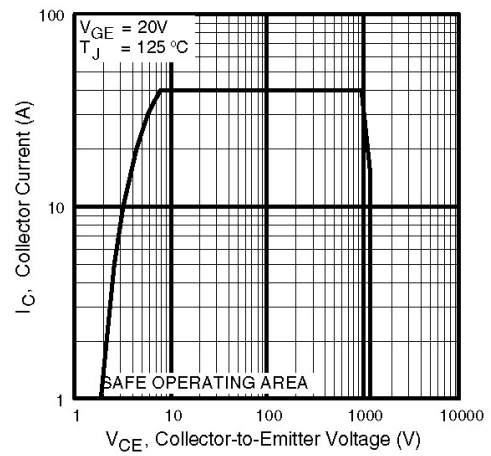


**Fig. 10** - Typical Switching Losses vs. Junction Temperature

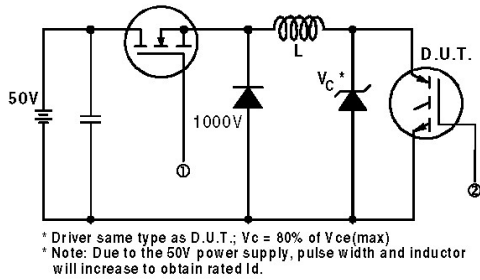
# IRG4PH30KPbF



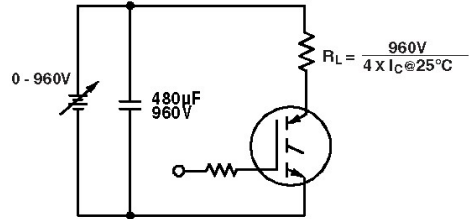
**Fig. 11** - Typical Switching Losses vs. Collector-to-Emitter Current



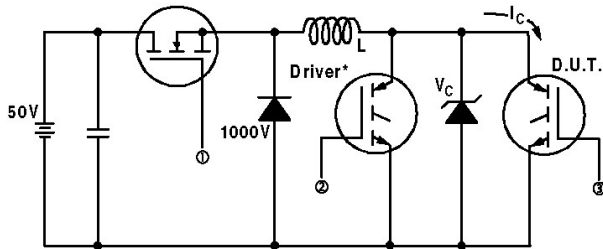
**Fig. 12** - Turn-Off SOA



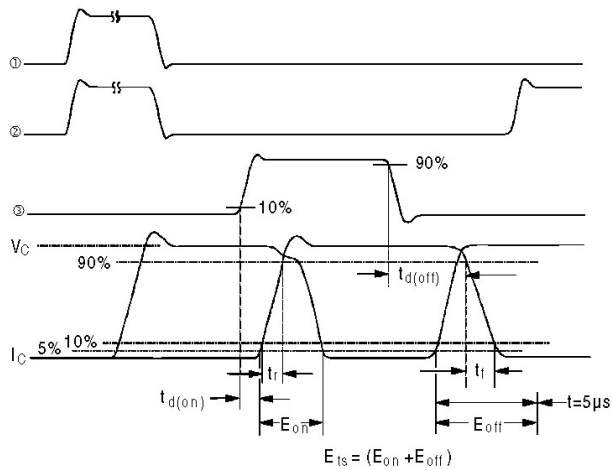
**Fig. 13a** - Clamped Inductive Load Test Circuit



**Fig. 13b** - Pulsed Collector Current Test Circuit



**Fig. 14a** - Switching Loss Test Circuit



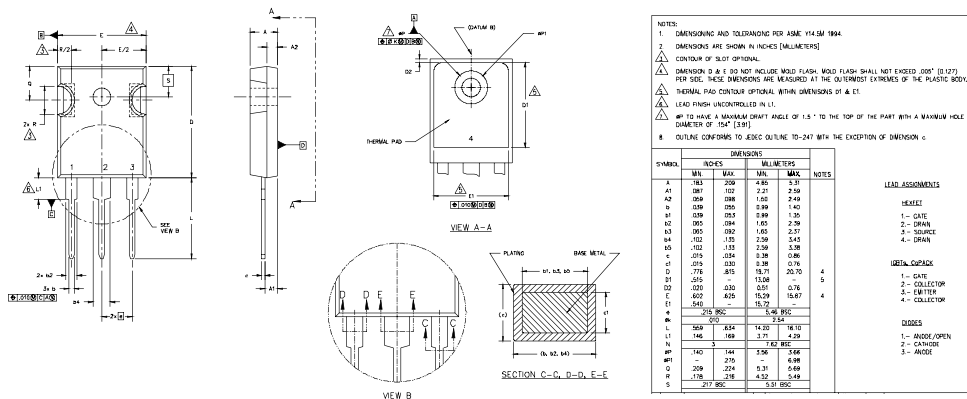
**Fig. 14b** - Switching Loss Waveforms

# IRG4PH30KPbF

International  
**IR** Rectifier

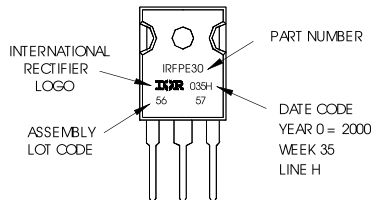
## TO-247AC Package Outline

Dimensions are shown in millimeters (inches)



## TO-247AC Part Marking Information

EXAMPLE: THIS IS AN IRFPE30  
WITH ASSEMBLY  
LOT CODE 5667  
ASSEMBLED ON WW 35, 2000  
IN THE ASSEMBLY LINE "H"  
**Note:** "P" in assembly line  
position indicates "Lead-Free"



Data and specifications subject to change without notice.

International  
**IR** Rectifier

IR WORLD HEADQUARTERS: 233 Kansas St., El Segundo, California 90245, USA Tel: (310) 252-7105  
TAC Fax: (310) 252-7903

Visit us at [www.irf.com](http://www.irf.com) for sales contact information.06/04

[www.irf.com](http://www.irf.com)



Note: For the most current drawings please refer to the IR website at:  
<http://www.irf.com/package/>