

# AZ696

## PCN Notice

Discontinuation date of silver cadmium oxide contacts: 31.12.2017

## 10 AMP SUBMINIATURE POWER RELAY

### FEATURES

- High sensitivity, 110 mW pickup
- Dielectric strength 4000 Vrms
- Isolation spacing greater than 8 mm
- Proof tracking index (PTI/CTI) 250
- 10 Amp switching capability
- Epoxy sealed version available
- Reinforced insulation, EN 60730-1 (VDE 0631, part 1) EN 60335-1 (VDE 0700, part 1)
- UL, CUR file E43203
- VDE file 40012571



### CONTACTS

<b>Arrangement</b>	SPST (1 Form C) SPST (1 Form A and 1 Form B)
<b>Ratings</b>	Resistive load:  Max. switched power: 300 W or 2500 VA Max. switched current: 10 A Max. switched voltage: 240 VDC* or 440 VAC  * Note: If switching voltage is greater than 30 VDC, special precautions must be taken. Please contact the factory.
<b>Rated Load UL</b>	10 A at 30 VDC, resistive 10 A at 250 VAC, general use 1/4 HP at 250 VAC 1/2 HP at 250 VAC B300
<b>VDE</b>	1 Form A / 1 Form B (unsealed) 10 A at 250VAC, resistive, 85°C, 50k cycles [2] 8 A at 250VAC, resistive, 40°C, 100k cycles [1] 5 A at 250VAC, cos phi 0.9, 70°C, 50k cycles [1]  1 Form C (unsealed) 10 A at 250VAC, resistive, 85°C, 50k cycles [2] 8 A at 250VAC, resistive, 40°C, 50k cycles [1] 4 A at 250VAC, cos phi 0.9, 70°C, 50k cycles [1]  1 Form A / 1 Form B / 1 Form C (sealed) 10 A at 250VAC, resistive, 85°C, 10k cycles [2]
<b>Material</b>	Silver cadmium oxide [1]*, silver tin oxide [2]  * Note: Silver cadmium oxide will be discontinued on 31.12.2017.
<b>Resistance</b>	< 30 milliohms initially (at 6 V, 1 A, voltage drop method)

### NOTES

1. All values at 20°C (68°F).
2. Relay may pull in with less than "Must Operate" value.
3. Specifications subject to change without notice.
4. It's recommended to remove vent nipple on sealed versions to expand life expectancy when switching higher loads.

### GENERAL DATA

<b>Life Expectancy</b> <b>Mechanical</b> <b>Electrical</b>	Minimum operations 1 x 10 <sup>7</sup> 1 x 10 <sup>5</sup> at 8 A 250 VAC Res.
<b>Operate Time (typical)</b>	10 ms at nominal coil voltage
<b>Release Time (typical)</b>	5 ms at nominal coil voltage (with no coil suppression)
<b>Dielectric Strength (at sea level for 1 min.)</b>	4000 Vrms coil to contact 1000 Vrms between open contacts
<b>Insulation Resistance</b>	1000 megohms min. at 20°C, 500 VDC, 50% RH
<b>Insulation (according to DIN VDE 0110, IEC 60664-1)</b>	C250 Overvoltage category: III Pollution degree: 3 Nominal voltage: 250 VAC
<b>Dropout</b>	Greater than 10% of nominal coil voltage
<b>Ambient Temperature Operating</b>	At nominal coil voltage -40°C (-40°F) to 85°C (185°F)
<b>Vibration</b>	0.062" (1.5 mm) DA at 10–55 Hz
<b>Shock</b>	20 g
<b>Enclosure</b>	P.B.T. polyester, UL94 V-0
<b>Terminals</b>	Tinned copper alloy, P.C.
<b>Max. Solder Temp.</b>	270°C (518°F)
<b>Max. Solder Time</b>	5 seconds
<b>Max. Solvent Temp.</b>	80°C (176°F)
<b>Max. Immersion Time</b>	30 seconds
<b>Weight</b>	11 grams
<b>Packing unit in pcs</b>	50 per plastic tray / 1500 per carton box

### COIL

<b>Power</b>	
<b>At Pickup Voltage (typical)</b>	110 mW 140 mW (48 VDC coil)
<b>Max. Continuous Dissipation</b>	1.5 W at 20°C (68°F) ambient
<b>Temperature Rise</b>	20°C (36°F) at nominal coil voltage
<b>Temperature</b>	Max. 110°C (230°F)

## ZETTLER electronics GmbH - A ZETTLER GROUP Company

Junkersstr. 3, D-82178 Puchheim, Germany

phone: +49 89 800 97-0 office@ZETTLERelectronics.com

fax: +49 89 800 97-200 www.ZETTLERelectronics.com

This product specification to be used only together with the application notes which can be downloaded from <http://www.ZETTLERelectronics.com/pdfs/relais/ApplicationNotes.pdf>

2016-04-05

## RELAY ORDERING DATA

COIL SPECIFICATIONS				ORDER NUMBER*	
Nominal Coil VDC	Must Operate VDC	Max. Continuous VDC	Coil Resistance Ohm $\pm 10\%$	1 Form A (SPST-NO)	1 Form C (SPDT)
5	3.5	12.0	110	AZ696-1A-5D	AZ696-1C-5D
6	4.2	14.5	160	AZ696-1A-6D	AZ696-1C-6D
9	6.3	22.0	360	AZ696-1A-9D	AZ696-1C-9D
12	8.4	29.5	660	AZ696-1A-12D	AZ696-1C-12D
18	12.6	44.0	1,500	AZ696-1A-18D	AZ696-1C-18D
24	16.8	54.0	2,200	AZ696-1A-24D	AZ696-1C-24D
48	33.6	102.0	8,000	AZ696-1A-48D	AZ696-1C-48D

\* Substitute "1B" in place of "1A" for 1 Form B contact. Add suffix "E" to "1A" or "1B" or "1C" for silver tin oxide contacts. Add suffix "E" at the end of order number for sealed version.

Note: Silver cadmium oxide will be discontinued on 31.12.2017.

## MECHANICAL DATA

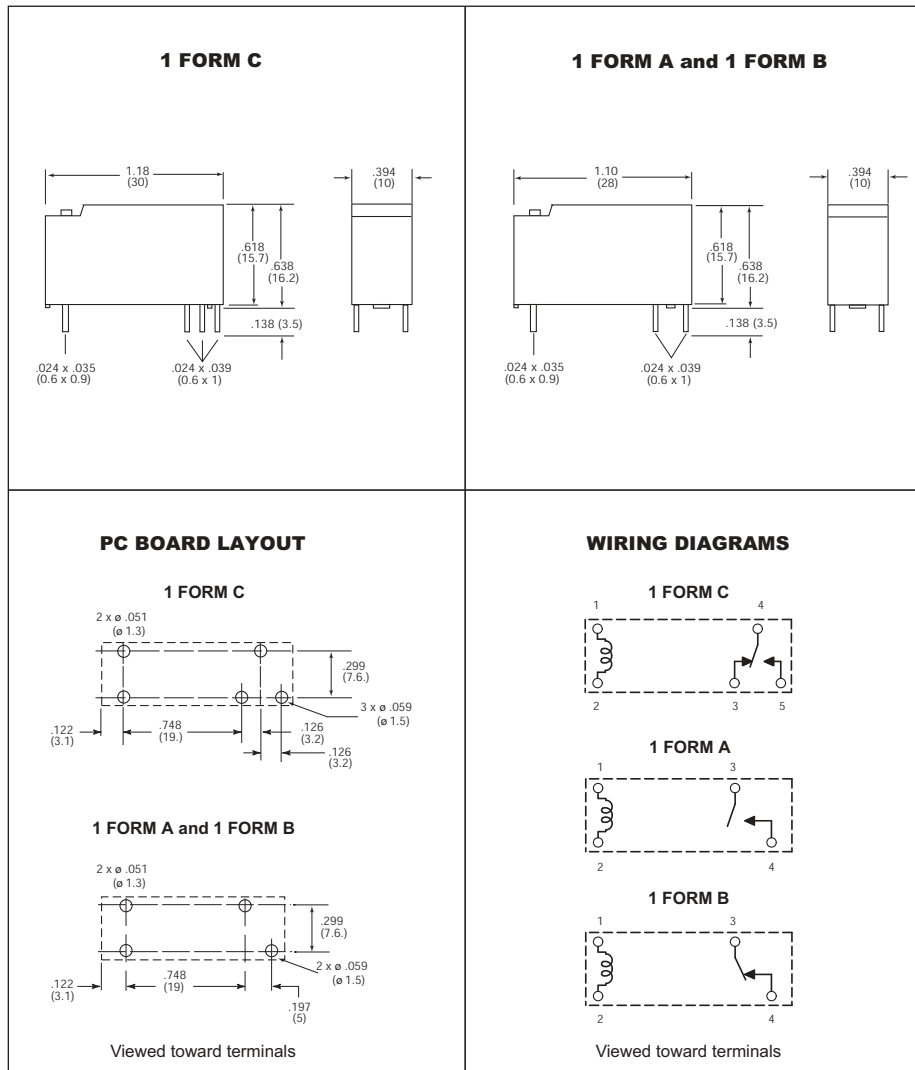

Dimensions in inches with metric equivalents in parentheses. Tolerance:  $\pm .010$ "

## Coil Temperature Rise

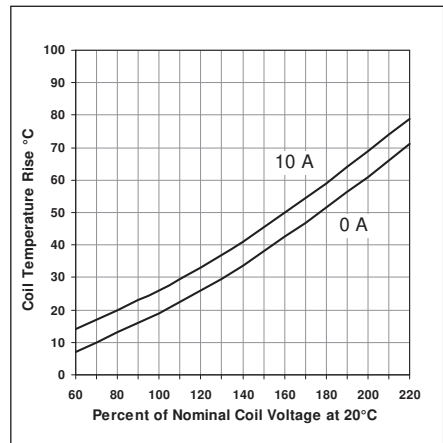

## Maximum Switching Capacity

