

DATASHEET

WLAN 11N USB MODULE 1R1T MODEL: M-RTL8188ETV

1. Application: SET-TOP BOX & Dongle

2. Key features

Item	Description
Chipset	Realtek RTL8188ETV
WiFi Standard	IEEE 802.11N,G,B
USB Connector	USB 2.0
Frequency Range	2.4...2.484 GHz
Channel quantity	14
Modulation	OFDM/DBPSK/DQPSK/CCK
Working Model	Infrastructure & Ad-Hoc
Transmitting Speed	150 Mbps
Sensitivity	54/135M: -68dBm@10%PER 11M: -85dBm@8%PER 6M: -88dBm@10%PER 1M: -90dBm@8%PER
RF	2 dbi
Transmitting Distance	100 Meters Indoor & 300 Meters Outdoor
Supporting System	WIN2000/XP/VISTA/7/8 & LINUX
Working Power	DC5.0V +/- 0.2V
Environmental	Operating Temperature: -10 °C to 60 °C Storage Temperature : -40 °C to 70 °C Operating Humidity : 5 to 95%
Size	27x12x2,2 mm

3. Product Working Diagram

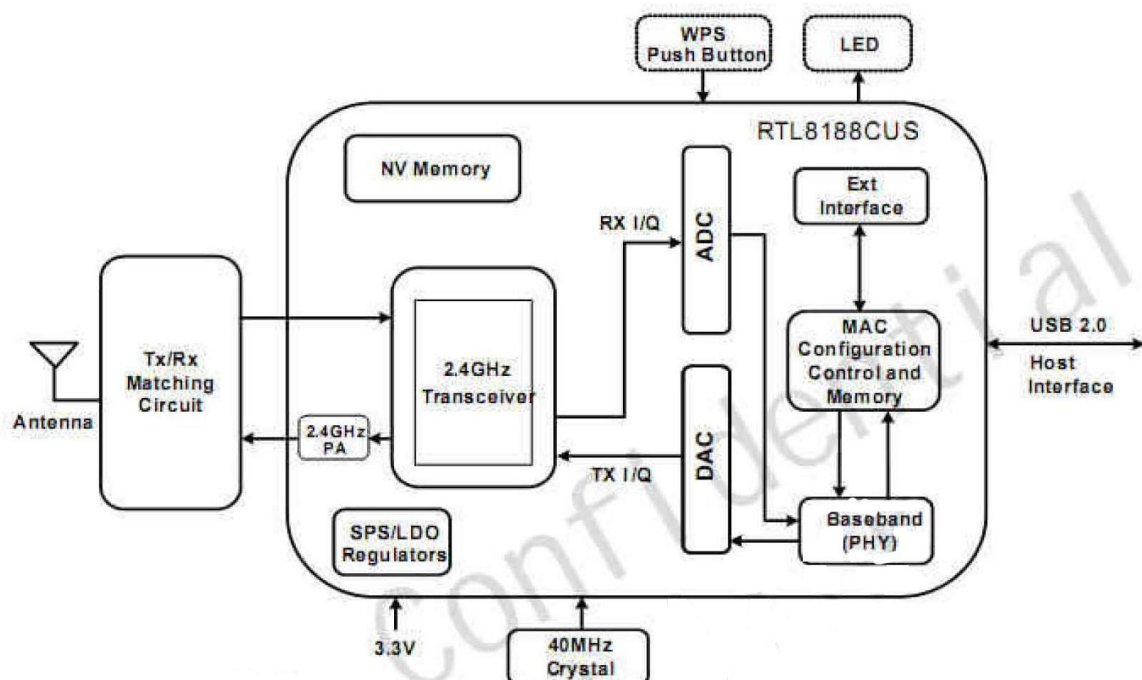

4. Testing Parameters

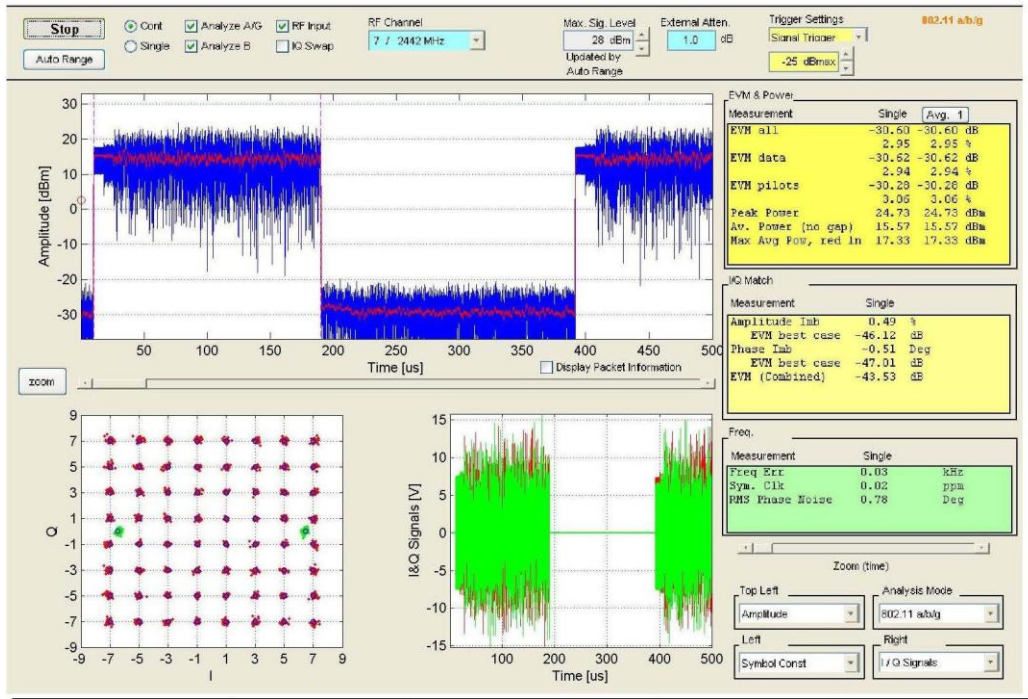

5. Product Structure

PIN ASSIGNMENT: 5pin pitch 2.0mm pin header



Pin.	Pin Define	Status
1	+5V	YES
2	USB D-	YES
3	USB D+	YES
4	GND	YES
5	NC	

6. Mechanical

