

## Aluminum Capacitors Power Printed Wiring Style

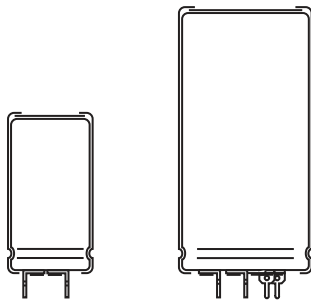

Component outlines



RoHS  
COMPLIANT

### FEATURES

- Polarized aluminum electrolytic capacitors, non-solid electrolyte
- Large types, cylindrical aluminum case, insulated
- Provided with keyed polarity
- Very long useful life: 15 000 h at 85 °C
- Low ESR, high ripple current capability
- High resistance to shock and vibration

### APPLICATIONS

- Computer, telecommunication and industrial systems
- Smoothing and filtering
- Standard and switched mode power supplies
- Energy storage in pulse systems

### MARKING

The capacitors are marked (where possible) with the following information:

- Rated capacitance (in  $\mu\text{F}$ )
- Tolerance on rated capacitance, code letter in accordance with IEC 60062 (Q for - 10 %/+ 30 %)
- Rated voltage (in V)
- Date code (YYMM)
- Name of manufacturer
- Code for factory of origin
- Polarity of the terminals and '-' sign to indicate the negative terminal, visible from the top and/or side of the capacitor
- Code number
- Climatic category in accordance with IEC 60068

### QUICK REFERENCE DATA

DESCRIPTION	VALUE	
	$\leq 100 \text{ V}$	$> 100 \text{ V}$
Nominal case size ( $\varnothing D \times L$ in mm)	25 x 30 to 40 x 100	
Rated capacitance range (E6 series), $C_R$	470 $\mu\text{F}$ to 68 000 $\mu\text{F}$	47 $\mu\text{F}$ to 1000 $\mu\text{F}$
Tolerance on $C_R$	- 10 % to + 30 %	
Rated voltage range, $U_R$	10 V to 100 V	250 V to 400 V
Category temperature range	- 40 °C to + 85 °C	
Endurance test at 85 °C	5000 h	
Useful life at 85 °C	15 000 h	
Useful life at 40 °C, 1.4 x $I_R$ applied	200 000 h	
Shelf life at 0 V, 85 °C	500 h	
Based on sectional specification	IEC 60384-4/EN130300	
Climatic category IEC 60068	40/085/56	

### SELECTION CHART FOR $C_R$ , $U_R$ AND RELEVANT NOMINAL CASE SIZES ( $\varnothing D \times L$ in mm)

$C_R$ ( $\mu\text{F}$ )	$U_R$ (V)					
	10	16	25	40	63	100
470	-	-	-	-	-	25 x 30
680	-	-	-	-	-	25 x 40
1000	-	-	-	-	25 x 30	30 x 40
1500	-	-	-	25 x 30	25 x 40	35 x 40
2200	-	-	25 x 30	25 x 40	30 x 40	35 x 50
	-	-	-	-	-	40 x 40
3300	-	25 x 30	25 x 40	30 x 40	35 x 40	40 x 50
	25 x 30	25 x 40	30 x 40	35 x 40	35 x 50	40 x 70
4700	-	-	-	-	40 x 40	-
	25 x 40	30 x 40	35 x 40	35 x 50	40 x 50	40 x 100
6800	-	-	-	40 x 40	-	-
	30 x 40	35 x 40	35 x 50	40 x 50	40 x 70	-
10 000	-	-	40 x 40	-	-	-
	35 x 40	35 x 50	40 x 50	40 x 70	40 x 100	-
15 000	-	40 x 40	-	-	-	-
	35 x 50	40 x 50	40 x 70	40 x 100	-	-
22 000	40 x 40	-	-	-	-	-
	40 x 50	40 x 70	40 x 100	-	-	-
33 000	40 x 70	40 x 100	-	-	-	-
47 000	40 x 100	-	-	-	-	-
68 000	-	-	-	-	-	-



SELECTION CHART FOR $C_R$ , $U_R$ AND RELEVANT NOMINAL CASE SIZES ( $\varnothing D \times L$ in mm)			
$C_R$ ( $\mu F$ )	$U_R$ (V)		
	250	385	400
47	-	25 x 30	25 x 30
68	-	25 x 40	25 x 40
100	25 x 30	30 x 40	30 x 40
150	25 x 40	35 x 40	35 x 40
220	30 x 40	35 x 50	35 x 50
	-	40 x 40	40 x 40
330	35 x 40	40 x 50	40 x 50
470	35 x 50	40 x 70	40 x 70
	40 x 40	-	-
680	40 x 50	-	40 x 100
1000	40 x 70	-	-

**DIMENSIONS** in millimeters **AND AVAILABLE FORMS**

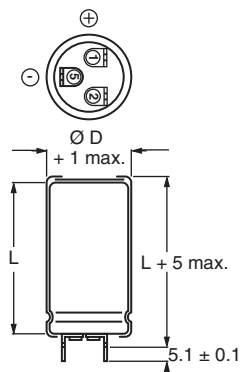

1 = Positive terminal  
5 = Negative terminal  
Case  $\varnothing D = 25$  mm

Fig.1 Printed wiring pin version

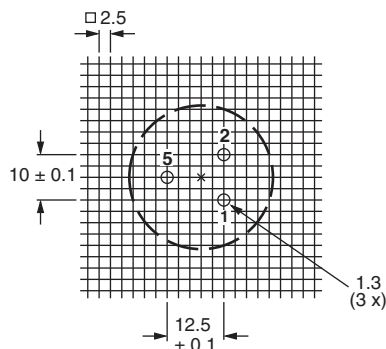

Case  $\varnothing D = 25$  mm

Fig.2 Mounting hole pattern viewed from the component side

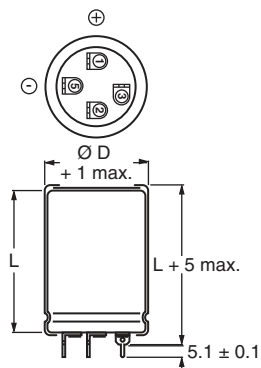

1 = Positive terminal  
5 = Negative terminal  
Case  $\varnothing D = 30$  mm and 35 mm

Fig.3 Printed wiring pin version

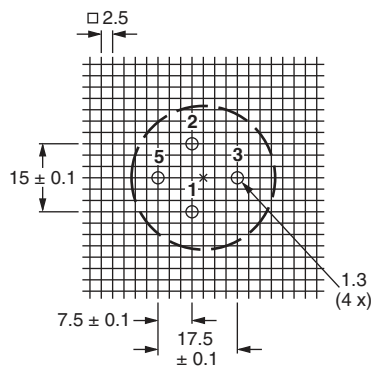

Case  $\varnothing D = 30$  mm and 35 mm

Fig.4 Mounting hole pattern viewed from the component side

**DIMENSIONS** in millimeters **AND AVAILABLE FORMS**

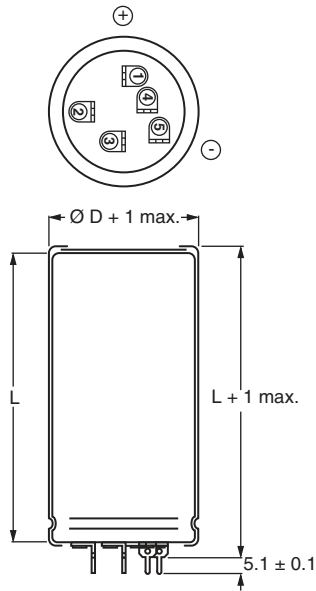

1 = Positive terminal  
5 = Negative terminal  
Case Ø D = 40 mm

Fig.5 Printed wiring pin version

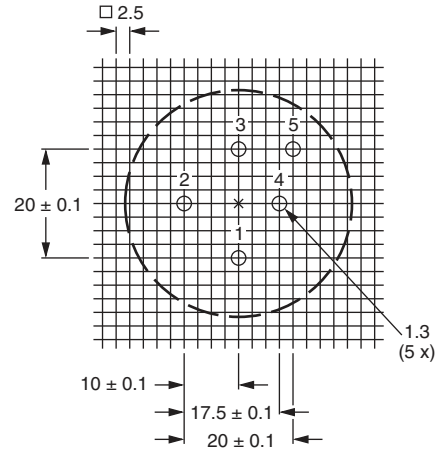

1 = Positive terminal  
5 = Negative terminal  
Case Ø D = 40 mm

Fig.6 Mounting hole pattern viewed from the component side

<b>DIMENSIONS</b> in millimeters, <b>MASS AND PACKAGING QUANTITIES</b>					
NOMINAL CASE SIZE Ø D x L	Ø D <sub>max.</sub>	L <sub>max.</sub>	MASS (g)	PACKAGING QUANTITIES (units per box)	CARDBOARD BOX DIMENSIONS L x W x H
25 x 30	26	35	≈ 24	100	290 x 280 x 50
25 x 40	26	45	≈ 28	100	290 x 280 x 60
30 x 40	31	45	≈ 38	100	340 x 330 x 60
35 x 40	36	45	≈ 51	50	390 x 198 x 60
35 x 50	36	55	≈ 66	50	390 x 198 x 70
40 x 40	41	45	≈ 78	50	440 x 223 x 60
40 x 50	41	55	≈ 82	50	440 x 223 x 70
40 x 70	41	75	≈ 110	25	230 x 230 x 90
40 x 100	41	105	≈ 176	25	230 x 230 x 120

**MOUNTING**

When a number of capacitors are connected in a bank, they must not be closer together than 15 mm, when no derating of ripple current and/or temperature is applied.

**Pin numbers 2, 3 and 4 (if present) must be free from the electrical circuit.**



Aluminum Capacitors  
Power Printed Wiring Style

Vishay Roederstein

ELECTRICAL DATA	
SYMBOL	DESCRIPTION
$C_R$	rated capacitance at 100 Hz
$I_R$	rated RMS ripple current at 100 Hz, 85 °C or at 20 kHz, 70 °C
$I_{L1}$	max. leakage current after 1 minute at $U_R$
$I_{L5}$	max. leakage current after 5 minutes at $U_R$
ESR	max. equivalent series resistance at 100 Hz
Z	max. impedance at 10 kHz

**ORDERING EXAMPLE**

10 000  $\mu$ F/25 V; - 10 %/+ 30 %

Nominal case size:  $\varnothing$  35 mm x 50 mm

Ordering code: MALPEYV00CD510E02W

**Note**

- Unless otherwise specified, all electrical values apply at  $T_{amb} = 20 \text{ }^\circ\text{C}$ ,  $P = 86 \text{ kPa}$  to  $106 \text{ kPa}$ ,  $RH = 45 \text{ \%}$  to  $75 \text{ \%}$

ELECTRICAL DATA AND ORDERING INFORMATION									
$U_R$ (V)	$C_R$ 100 Hz ( $\mu$ F)	NOMINAL CASE SIZE $\varnothing$ D x L (mm)	$I_R$ 100 Hz 85 °C (A)	$I_R$ 20 kHz 70 °C (A)	$I_{L1}$ 1 min (mA)	$I_{L5}$ 5 min (mA)	ESR 100 Hz (m $\Omega$ )	Z 10 kHz (m $\Omega$ )	ORDERING CODE
10	4700	25 x 30	2.4	4.6	0.28	0.10	74	50	MALPEYV00AV447C02W
	6800	25 x 40	3.2	6.1	0.41	0.14	51	37	MALPEYV00AB468C02W
	10 000	30 x 40	3.8	7.2	0.60	0.20	39	29	MALPEYV00BB510C02W
	15 000	35 x 40	4.1	7.8	0.90	0.30	35	26	MALPEYV00CB515C02W
	22 000	35 x 50	5.0	9.5	1.32	0.44	27	21	MALPEYV00CD522C02W
	22 000	40 x 40	4.2	8.0	1.32	0.44	36	27	MALPEYV00DB522C02W
	33 000	40 x 50	5.0	9.5	1.98	0.66	29	22	MALPEYV00DD533C02W
	47 000	40 x 70	6.8	12.9	2.82	0.94	20	17	MALPEYV00DG547C02W
	68 000	40 x 100	9.2	17.5	4.08	1.36	15	14	MALPEYV00DM568C02W
16	3300	25 x 30	2.4	4.6	0.32	0.11	75	50	MALPEYV00AV433D02W
	4700	25 x 40	3.1	5.9	0.45	0.15	52	37	MALPEYV00AB447D02W
	6800	30 x 40	3.7	7.0	0.65	0.22	40	30	MALPEYV00BB468D02W
	10 000	35 x 40	4.1	7.8	0.96	0.32	36	27	MALPEYV00CB510D02W
	15 000	35 x 50	5.0	9.5	1.44	0.48	28	21	MALPEYV00CD515D02W
	15 000	40 x 40	4.2	8.0	1.44	0.48	36	27	MALPEYV00DB515D02W
	22 000	40 x 50	5.0	9.5	2.12	0.71	29	22	MALPEYV00DD522D02W
	33 000	40 x 70	6.7	12.7	3.17	1.06	20	17	MALPEYV00DG533D02W
	47 000	40 x 100	9.1	17.3	4.51	1.51	15	14	MALPEYV00DM547D02W
25	2200	25 x 30	2.3	4.4	0.33	0.11	78	52	MALPEYV00AV422E02W
	3300	25 x 40	3.1	5.9	0.49	0.17	53	38	MALPEYV00AB433E02W
	4700	30 x 40	3.7	7.0	0.70	0.24	42	31	MALPEYV00BB447E02W
	6800	35 x 40	4.1	7.8	1.02	0.34	37	28	MALPEYV00CB468E02W
	10 000	35 x 50	5.0	9.5	1.50	0.50	28	21	MALPEYV00CD510E02W
	10 000	40 x 40	4.2	8.0	1.50	0.50	36	27	MALPEYV00DB510E02W
	15 000	40 x 50	5.0	9.5	2.25	0.75	29	22	MALPEYV00DD515E02W
	22 000	40 x 70	6.8	12.9	3.30	1.10	20	17	MALPEYV00DG522E02W
	33 000	40 x 100	9.2	17.5	4.95	1.65	15	14	MALPEYV00DM533E02W
40	1500	25 x 30	2.0	3.8	0.36	0.12	112	68	MALPEYV00AV415G02W
	2200	25 x 40	2.7	5.1	0.53	0.18	76	51	MALPEYV00AB422G02W
	3300	30 x 40	3.3	6.3	0.79	0.27	57	41	MALPEYV00BB433G02W
	4700	35 x 40	3.8	7.2	1.13	0.38	48	35	MALPEYV00CB447G02W
	6800	35 x 50	4.7	8.9	1.64	0.55	36	27	MALPEYV00CD468G02W
	6800	40 x 40	4.1	7.8	1.64	0.55	45	33	MALPEYV00DB468G02W
	10 000	40 x 50	4.9	9.3	2.40	0.80	35	27	MALPEYV00DD510G02W
	15 000	40 x 70	6.6	12.5	3.60	1.20	25	20	MALPEYV00DG515G02W
	22 000	40 x 100	9.0	17.1	5.28	1.76	18	16	MALPEYV00DM522G02W
63	1000	25 x 30	1.8	3.4	0.38	0.13	122	74	MALPEYV00AV410J02W
	1500	25 x 40	2.5	4.7	0.57	0.19	83	54	MALPEYV00AB415J02W
	2200	30 x 40	3.1	5.9	0.83	0.28	57	41	MALPEYV00BB422J02W
	3300	35 x 40	3.6	6.8	1.25	0.42	48	35	MALPEYV00CB433J02W
	4700	35 x 50	4.4	8.3	1.78	0.60	36	27	MALPEYV00CD447J02W
	4700	40 x 40	3.8	7.2	1.78	0.60	45	33	MALPEYV00DB447J02W
	6800	40 x 50	4.7	8.9	2.57	0.86	35	27	MALPEYV00DD468J02W
	10 000	40 x 70	6.2	11.8	3.78	1.26	25	20	MALPEYV00DG510J02W
	15 000	40 x 100	8.5	16.1	5.67	1.89	18	16	MALPEYV00DM515J02W

ELECTRICAL DATA AND ORDERING INFORMATION									
U <sub>R</sub> (V)	C <sub>R</sub> 100 Hz (μF)	NOMINAL CASE SIZE Ø D x L (mm)	I <sub>R</sub> 100 Hz 85 °C (A)	I <sub>R</sub> 20 kHz 70 °C (A)	I <sub>L1</sub> 1 min (mA)	I <sub>L5</sub> 5 min (mA)	ESR 100 Hz (mΩ)	Z 10 kHz (mΩ)	ORDERING CODE
100	470	25 x 30	1.4	2.7	0.28	0.10	247	172	MALPEYV00AV347L02W
	680	25 x 40	1.9	3.6	0.41	0.14	170	116	MALPEYV00AB368L02W
	1000	30 x 40	2.5	4.7	0.60	0.20	123	88	MALPEYV00BB410L02W
	1500	35 x 40	3.1	5.8	0.90	0.30	94	71	MALPEYV00CB415L02W
	2200	35 x 50	3.9	7.4	1.32	0.44	69	55	MALPEYV00CD422L02W
	2200	40 x 40	3.6	6.8	1.32	0.44	81	65	MALPEYV00DB422L02W
	3300	40 x 50	4.6	8.7	1.98	0.66	59	48	MALPEYV00DD433L02W
	4700	40 x 70	6.2	11.7	2.82	0.94	42	36	MALPEYV00DG447L02W
6800	40 x 100	8.2	15.5	4.08	1.36	32	28	MALPEYV00DM468L02W	
250	100	25 x 30	0.6	1.15	0.15	0.05	1800	1300	MALPEYV00AV310N02W
	150	25 x 40	0.8	1.5	0.23	0.08	1100	850	MALPEYV00AB315N02W
	220	30 x 40	1.0	1.9	0.33	0.11	750	550	MALPEYV00BB322N02W
	330	35 x 40	1.4	2.65	0.49	0.17	500	400	MALPEYV00CB333N02W
	470	35 x 50	1.8	3.4	0.70	0.24	360	290	MALPEYV00CD347N02W
	470	40 x 40	1.8	3.4	0.70	0.24	420	350	MALPEYV00DB347N02W
	680	40 x 50	2.3	4.4	1.02	0.34	250	190	MALPEYV00DD368N02W
	1000	40 x 70	3.0	5.7	1.50	0.50	170	140	MALPEYV00DG410N02W
385	47	25 x 30	0.5	0.94	0.11	0.04	2370	1550	MALPEYV00AV247R02W
	68	25 x 40	0.67	1.27	0.16	0.06	1640	1100	MALPEYV00AB268R02W
	100	30 x 40	0.84	1.59	0.23	0.08	1275	950	MALPEYV00BB310R02W
	150	35 x 40	1.13	2.14	0.34	0.11	850	635	MALPEYV00CB315R02W
	220	35 x 50	1.48	2.8	0.50	0.17	580	430	MALPEYV00CD322R02W
	220	40 x 40	1.48	2.8	0.50	0.17	580	430	MALPEYV00DB322R02W
	330	40 x 50	1.97	3.73	0.75	0.25	385	300	MALPEYV00DD333R02W
	470	40 x 70	2.7	5.11	1.06	0.36	270	215	MALPEYV00DG347R02W
400	47	25 x 30	0.47	0.89	0.11	0.04	2700	2125	MALPEYV00AV247X02W
	68	25 x 40	0.63	1.29	0.16	0.06	1875	1470	MALPEYV00AB268X02W
	100	30 x 40	0.84	1.59	0.24	0.08	1275	1000	MALPEYV00BB310X02W
	150	35 x 40	1.13	2.14	0.36	0.12	850	665	MALPEYV00CB315X02W
	220	35 x 50	1.41	2.67	0.52	0.17	650	450	MALPEYV00CD322X02W
	220	40 x 40	1.41	2.67	0.52	0.17	650	450	MALPEYV00DB322X02W
	330	40 x 50	1.86	3.52	0.79	0.26	435	315	MALPEYV00DD333X02W
	470	40 x 70	2.54	4.81	1.12	0.37	305	225	MALPEYV00DG347X02W
680	40 x 100	3.56	6.75	1.63	0.54	210	155	MALPEYV00DM368X02W	

Note

- 450 V on request

ADDITIONAL ELECTRICAL DATA		
PARAMETER	CONDITIONS	VALUE
<b>Voltage</b>		
Surge voltage	≤ 250 V versions	U <sub>s</sub> = 1.15 x U <sub>R</sub>
	≥ 385 V versions	U <sub>s</sub> = 1.1 x U <sub>R</sub>
Reverse voltage		U <sub>rev</sub> ≤ 1 V
<b>Current</b>		
Leakage current	After 1 minute at U <sub>R</sub>	I <sub>L1</sub> ≤ 0.006 C <sub>R</sub> x U <sub>R</sub> + 4 μA
	After 5 minutes at U <sub>R</sub>	I <sub>L5</sub> ≤ 0.002 C <sub>R</sub> x U <sub>R</sub> + 4 μA
<b>Inductance</b>		
Equivalent series inductance (ESL)	Case Ø D = 25 mm	max. 25 nH
	Case Ø D = 30 mm and 35 mm	max. 30 nH
	Case Ø D = 40 mm	max. 35 nH



Aluminum Capacitors  
Power Printed Wiring Style

Vishay Roederstein

**LIFETIME TABLE** rated voltage: ≤ 100 V

<b>INTERRELATION BETWEEN ALTERNATING CURRENT, AMBIENT TEMPERATURE AND LIFETIME</b>																
$I/I_R$ (frequency dependent)						SURFACE TEMPERATURE RISE $\Delta T_0$ (°C)	LIFETIME MULTIPLIER (depending on $I/I_R$ and $T_{amb}$ )									
FREQUENCY (Hz)							AMBIENT TEMPERATURE $T_{amb}$ (°C)									
50	100	250	500	1000	> 2500		40	45	50	55	60	65	70	75	80	85
0.19	0.20	0.21	0.22	0.22	0.23	0.2	63	40	26	17	11	7.3	5.0	3.4	2.3	1.63
0.38	0.40	0.42	0.43	0.45	0.47	0.7	55	35	23	15	9.9	6.7	4.5	3.1	2.2	1.51
0.56	0.60	0.63	0.65	0.67	0.70	1.5	45	29	19	13	8.5	5.7	3.9	2.7	1.9	1.33
0.75	0.80	0.84	0.86	0.89	0.94	2.5	35	23	15	10	6.9	4.7	3.3	2.3	1.6	1.13
0.94	1.00	1.05	1.08	1.12	1.17	3.8	26	17	12	7.9	5.4	3.7	2.6	1.8	1.3	1.00
1.13	1.20	1.26	1.29	1.34	1.41	5.4	18	13	8.6	5.9	4.1	2.9	2.0	1.4	1.0	
1.31	1.40	1.47	1.51	1.56	1.64	7.4	13	8.7	6.1	4.2	3.0	2.1	1.5	1.1		
1.50	1.60	1.68	1.72	1.79	1.87	9.6	8.3	5.9	4.2	3.0	2.1	1.5	1.1			
1.69	1.80	1.89	1.94	2.01	2.11	12	5.4	3.9	2.8	2.0	1.4	1.0				
1.88	2.00	2.10	2.15	2.23	2.34	15	3.4	2.5	1.8	1.3						
2.06	2.20	2.30	2.37	2.45	2.58	18	2.1	1.5	1.1							
2.25	2.40	2.51	2.58	2.68	2.81	21	1.2									

**Notes**

- $I_R$  100 Hz alternating current (A) at upper category temperature  $T_{UC}$  taken from datasheet
- $I$  User current (A)
- $T_{amb}$  Ambient temperature of capacitor (°C)
- $\Delta T_0$  Surface temperature rise of capacitor caused by AC load (°C)
- $L$  Lifetime multiplier

**LIFETIME TABLE** rated voltage: > 100 V

<b>INTERRELATION BETWEEN ALTERNATING CURRENT, AMBIENT TEMPERATURE AND LIFETIME</b>																
$I/I_R$ (frequency dependent)						SURFACE TEMPERATURE RISE $\Delta T_0$ (°C)	LIFETIME MULTIPLIER (depending on $I/I_R$ and $T_{amb}$ )									
FREQUENCY (Hz)							AMBIENT TEMPERATURE $T_{amb}$ (°C)									
50	100	250	500	1000	> 2500		40	45	50	55	60	65	70	75	80	85
0.16	0.20	0.26	0.29	0.31	0.33	0.2	78	50	32	21	14	9.2	6.2	4.2	2.3	1.64
0.31	0.40	0.51	0.58	0.63	0.66	0.6	68	44	29	19	12	8.4	5.7	3.1	2.2	1.53
0.47	0.60	0.77	0.87	0.94	0.99	1.3	56	37	24	16	11	7.3	5.0	2.8	1.9	1.36
0.62	0.80	1.03	1.16	1.25	1.32	2.3	43	29	19	13	8.9	6.1	4.2	2.4	1.7	1.18
0.78	1.00	1.29	1.45	1.57	1.65	3.4	32	22	15	10	7.1	4.9	2.8	2.0	1.4	1.00
0.93	1.20	1.54	1.74	1.88	1.98	5.3	23	16	11	7.8	5.5	3.1	2.2	1.6	1.1	
1.09	1.40	1.80	2.04	2.19	2.31	7.2	16	12	8.2	5.8	4.1	2.4	1.7	1.2		
1.24	1.60	2.06	2.33	2.51	2.64	9.3	11	8.0	5.8	4.2	2.4	1.7	1.3			
1.40	1.80	2.31	2.62	2.82	2.97	12	7.4	5.4	3.2	2.3	1.7	1.3				
1.56	2.00	2.57	2.91	3.13	3.30	14	4.9	2.9	2.2	1.6	1.2					
1.71	2.20	2.83	3.20	3.45	3.63	17	2.5	1.9	1.5	1.1						
1.86	2.40	3.09	3.49	3.76	3.96	19	1.6	1.2								
2.02	2.60	3.34	3.78	4.07	4.29	22	1.0									

**Notes**

- $I_R$  100 Hz alternating current (A) at upper category temperature  $T_{UC}$  taken from datasheet
- $I$  User current (A)
- $T_{amb}$  Ambient temperature of capacitor (°C)
- $\Delta T_0$  Surface temperature rise of capacitor caused by AC load (°C)
- $L$  Lifetime multiplier



## **Disclaimer**

ALL PRODUCT, PRODUCT SPECIFICATIONS AND DATA ARE SUBJECT TO CHANGE WITHOUT NOTICE TO IMPROVE RELIABILITY, FUNCTION OR DESIGN OR OTHERWISE.

Vishay Intertechnology, Inc., its affiliates, agents, and employees, and all persons acting on its or their behalf (collectively, "Vishay"), disclaim any and all liability for any errors, inaccuracies or incompleteness contained in any datasheet or in any other disclosure relating to any product.

Vishay makes no warranty, representation or guarantee regarding the suitability of the products for any particular purpose or the continuing production of any product. To the maximum extent permitted by applicable law, Vishay disclaims (i) any and all liability arising out of the application or use of any product, (ii) any and all liability, including without limitation special, consequential or incidental damages, and (iii) any and all implied warranties, including warranties of fitness for particular purpose, non-infringement and merchantability.

Statements regarding the suitability of products for certain types of applications are based on Vishay's knowledge of typical requirements that are often placed on Vishay products in generic applications. Such statements are not binding statements about the suitability of products for a particular application. It is the customer's responsibility to validate that a particular product with the properties described in the product specification is suitable for use in a particular application. Parameters provided in datasheets and / or specifications may vary in different applications and performance may vary over time. All operating parameters, including typical parameters, must be validated for each customer application by the customer's technical experts. Product specifications do not expand or otherwise modify Vishay's terms and conditions of purchase, including but not limited to the warranty expressed therein.

Except as expressly indicated in writing, Vishay products are not designed for use in medical, life-saving, or life-sustaining applications or for any other application in which the failure of the Vishay product could result in personal injury or death. Customers using or selling Vishay products not expressly indicated for use in such applications do so at their own risk. Please contact authorized Vishay personnel to obtain written terms and conditions regarding products designed for such applications.

No license, express or implied, by estoppel or otherwise, to any intellectual property rights is granted by this document or by any conduct of Vishay. Product names and markings noted herein may be trademarks of their respective owners.