

DRAFT ANGLE OF APPROXIMATELY 1°

SIDE VIEW OF BOX

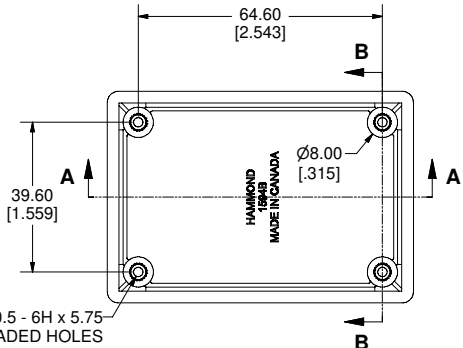

TOP VIEW OF BOX

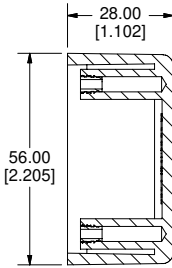

SECTION B-B  
SCALE 1 : 1

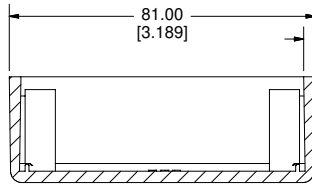

SECTION A-A  
SCALE 1 : 1

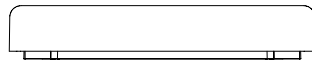

SIDE VIEW OF LID

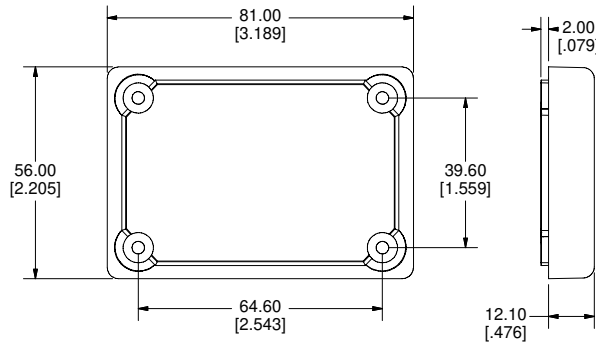

BOTTOM OF LID

SIDE VIEW OF LID

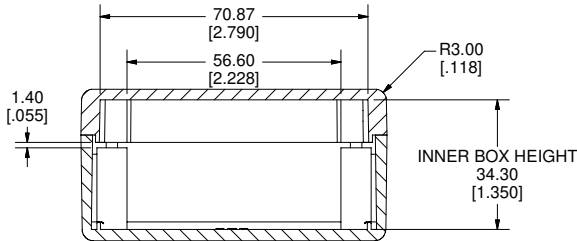
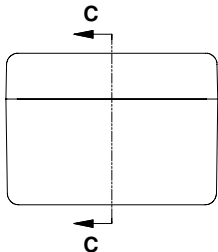

SECTION C-C  
SCALE 1 : 1

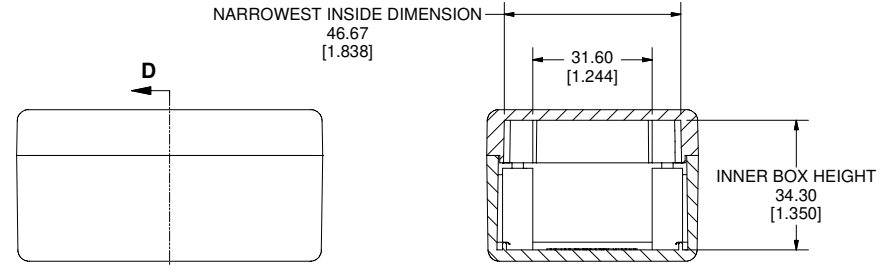

SECTION D-D  
SCALE 1 : 1

1594B Enclosure	
FLAME RETARDANT ABS	
Black - RAL 9011	1594BBK
Grey - RAL 7018	1594BGY
NON-FLAME RETARDANT ABS	
Grey - RAL 7035	1594BSGY
Black - RAL 9011	1594BSBK
LIQUID RESISTANT	
Black - RAL 9011	1594BWBK
ACCESSORIES	
Cover Screws Non-Flame Retardant (pkg. 100) [#4 x 1" Self-Tapping]	1594TS100
Cover Screws Flame Retardant (pkg. 100) [M3 - 0.5 x 20mm]	1594MS100
Cover Screws Liquid Resistant (pkg. 100) [M3 - 0.5 x 20mm]	1594WMS100
Circuit Board Holders	(See 1594Z Series)

Enclosures can be Factory Modified ( Milling, Drilling, Printing etc. )  
Solid models of this enclosure available in STEP or IGES.  
Contact Factory [mjm@hammondmfg.com](mailto:mjm@hammondmfg.com)