



ULN2001A-ULN2002A ULN2003A-ULN2004A

SEVEN DARLINGTON ARRAYS

- SEVEN DARLINGTONS PER PACKAGE
- OUTPUT CURRENT 500mA PER DRIVER (600mA PEAK)
- OUTPUT VOLTAGE 50V
- INTEGRATED SUPPRESSION DIODES FOR INDUCTIVE LOADS
- OUTPUTS CAN BE PARALLELED FOR HIGHER CURRENT
- TTL/CMOS/PMOS/DTL COMPATIBLE INPUTS
- INPUTS PINNED OPPOSITE OUTPUTS TO SIMPLIFY LAYOUT

DESCRIPTION

The ULN2001A, ULN2002A, ULN2003 and ULN2004A are high voltage, high current darlington arrays each containing seven open collector darlington pairs with common emitters. Each channel rated at 500mA and can withstand peak currents of 600mA. Suppression diodes are included for inductive load driving and the inputs are pinned opposite the outputs to simplify board layout.

The four versions interface to all common logic families :

| | |
|----------|---------------------------------------|
| ULN2001A | General Purpose, DTL, TTL, PMOS, CMOS |
| ULN2002A | 14-25V PMOS |
| ULN2003A | 5V TTL, CMOS |
| ULN2004A | 6-15V CMOS, PMOS |

These versatile devices are useful for driving a wide range of loads including solenoids, relays DC motors, LED displays filament lamps, thermal print-heads and high power buffers.

The ULN2001A/2002A/2003A and 2004A are supplied in 16 pin plastic DIP packages with a copper leadframe to reduce thermal resistance. They are available also in small outline package (SO-16) as ULN2001D/2002D/2003D/2004D.

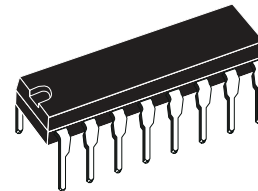

DIP16

ORDERING NUMBERS: ULN2001A/2A/3A/4A

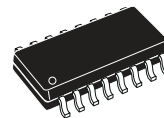

SO16

ORDERING NUMBERS: ULN2001D/2D/3D/4D

PIN CONNECTION

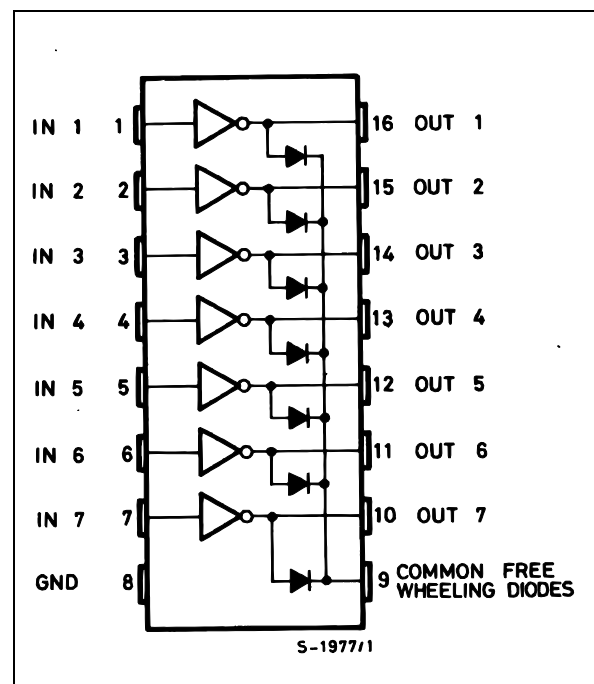

ULN2001A - ULN2002A - ULN2003A - ULN2004A

SCHEMATIC DIAGRAM

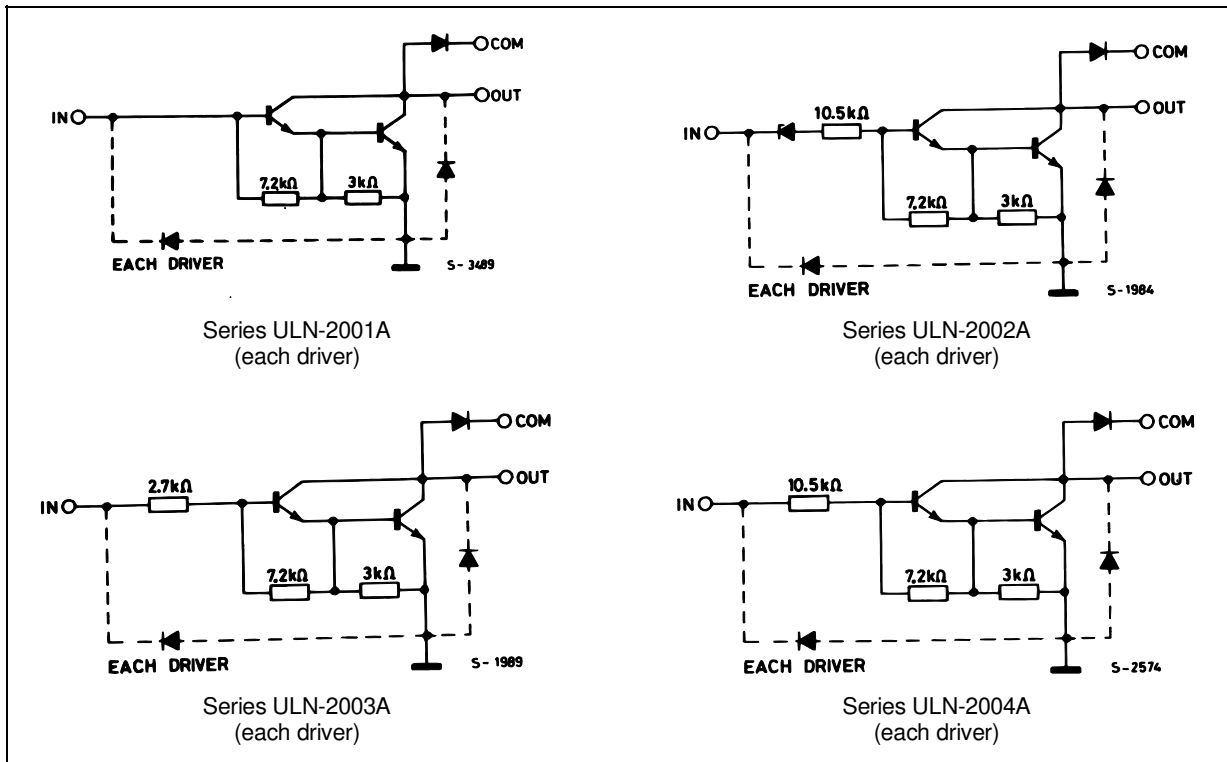

ABSOLUTE MAXIMUM RATINGS

| Symbol | Parameter | Value | Unit |
|-----------|--|-------------|------|
| V_o | Output Voltage | 50 | V |
| V_{in} | Input Voltage (for ULN2002A/D - 2003A/D - 2004A/D) | 30 | V |
| I_c | Continuous Collector Current | 500 | mA |
| I_b | Continuous Base Current | 25 | mA |
| T_{amb} | Operating Ambient Temperature Range | - 20 to 85 | °C |
| T_{stg} | Storage Temperature Range | - 55 to 150 | °C |
| T_j | Junction Temperature | 150 | °C |

THERMAL DATA

| Symbol | Parameter | DIP16 | SO16 | Unit |
|----------------|-------------------------------------|---------|------|------|
| $R_{th j-amb}$ | Thermal Resistance Junction-ambient | Max. 70 | 120 | °C/W |

ULN2001A - ULN2002A - ULN2003A - ULN2004A

ELECTRICAL CHARACTERISTICS ($T_{amb} = 25^{\circ}\text{C}$ unless otherwise specified)

| Symbol | Parameter | Test Conditions | Min. | Typ. | Max. | Unit | Fig. |
|---------------|--------------------------------------|--|------|------|------|---------------|------|
| I_{CEX} | Output Leakage Current | $V_{CE} = 50\text{V}$ | | | 50 | μA | 1a |
| | | $T_{amb} = 70^{\circ}\text{C}, V_{CE} = 50\text{V}$ | | | 100 | μA | 1a |
| | | $T_{amb} = 70^{\circ}\text{C}$ for ULN2002A $V_{CE} = 50\text{V}, V_i = 6\text{V}$ | | | 500 | μA | 1b |
| | | for ULN2004A $V_{CE} = 50\text{V}, V_i = 1\text{V}$ | | | 500 | μA | 1b |
| $V_{CE(sat)}$ | Collector-emitter Saturation Voltage | $I_C = 100\text{mA}, I_B = 250\mu\text{A}$ | | 0.9 | 1.1 | V | 2 |
| | | $I_C = 200\text{mA}, I_B = 350\mu\text{A}$ | | 1.1 | 1.3 | V | 2 |
| | | $I_C = 350\text{mA}, I_B = 500\mu\text{A}$ | | 1.3 | 1.6 | V | 2 |
| $I_{i(on)}$ | Input Current | for ULN2002A, $V_i = 17\text{V}$ | | 0.82 | 1.25 | mA | 3 |
| | | for ULN2003A, $V_i = 3.85\text{V}$ | | 0.93 | 1.35 | mA | 3 |
| | | for ULN2004A, $V_i = 5\text{V}$ | | 0.35 | 0.5 | mA | 3 |
| | | $V_i = 12\text{V}$ | | 1 | 1.45 | mA | 3 |
| $I_{i(off)}$ | Input Current | $T_{amb} = 70^{\circ}\text{C}, I_C = 500\mu\text{A}$ | 50 | 65 | | μA | 4 |
| $V_{i(on)}$ | Input Voltage | $V_{CE} = 2\text{V}$ for ULN2002A $I_C = 300\text{mA}$ | | | 13 | V | 5 |
| | | for ULN2003A $I_C = 200\text{mA}$ | | | 2.4 | | |
| | | $I_C = 250\text{mA}$ | | | 2.7 | | |
| | | $I_C = 300\text{mA}$ | | | 3 | | |
| | | for ULN2004A $I_C = 125\text{mA}$ | | | 5 | | |
| | | $I_C = 200\text{mA}$ | | | 6 | | |
| | | $I_C = 275\text{mA}$ | | | 7 | | |
| | | $I_C = 350\text{mA}$ | | | 8 | | |
| h_{FE} | DC Forward Current Gain | for ULN2001A $V_{CE} = 2\text{V}, I_C = 350\text{mA}$ | 1000 | | | | 2 |
| C_i | Input Capacitance | | | 15 | 25 | pF | |
| t_{PLH} | Turn-on Delay Time | $0.5 V_i$ to $0.5 V_o$ | | 0.25 | 1 | μs | |
| t_{PHL} | Turn-off Delay Time | $0.5 V_i$ to $0.5 V_o$ | | 0.25 | 1 | μs | |
| I_R | Clamp Diode Leakage Current | $V_R = 50\text{V}$ | | | 50 | μA | 6 |
| | | $T_{amb} = 70^{\circ}\text{C}, V_R = 50\text{V}$ | | | 100 | μA | 6 |
| V_F | Clamp Diode Forward Voltage | $I_F = 350\text{mA}$ | | 1.7 | 2 | V | 7 |

TEST CIRCUITS

Figure 1a.

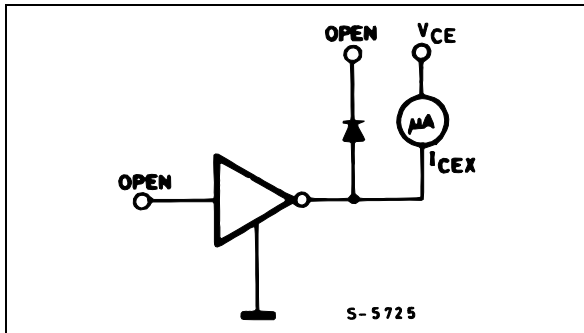

Figure 1b.

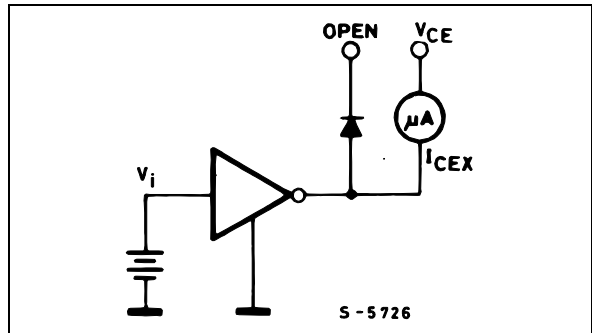

Figure 2.

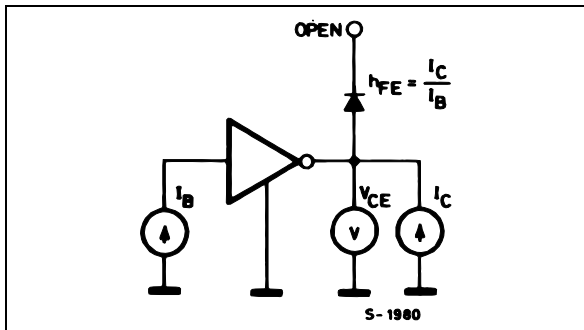

Figure 3.

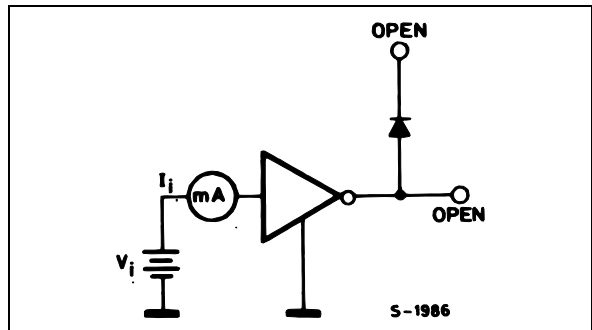

Figure 4.

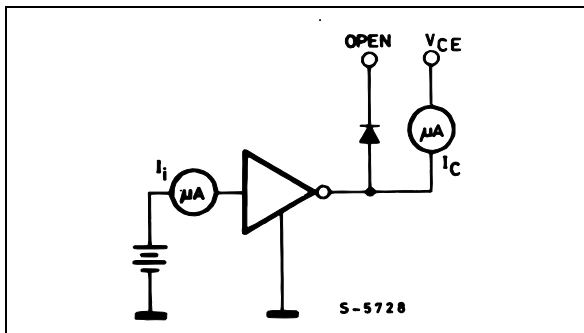

Figure 5.

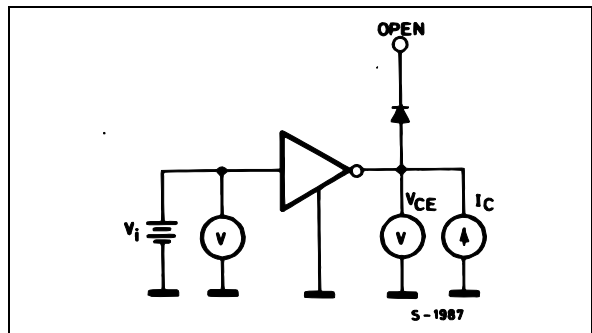

Figure 6.

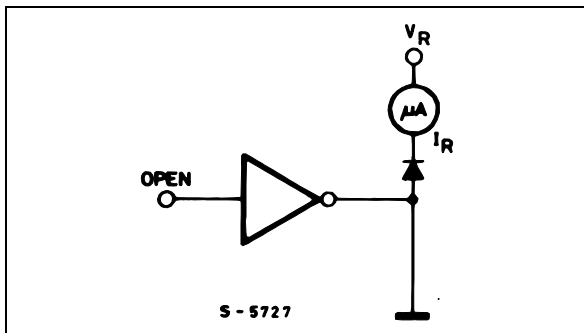

Figure 7.

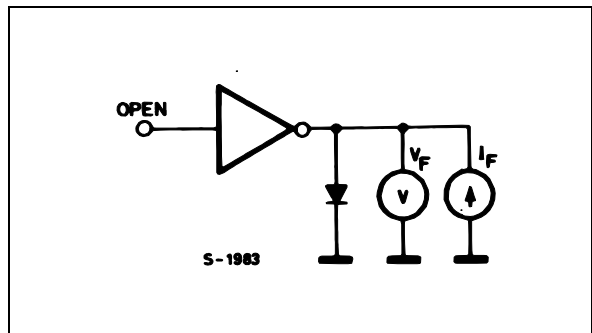

Figure 8: Collector Current versus Input Current

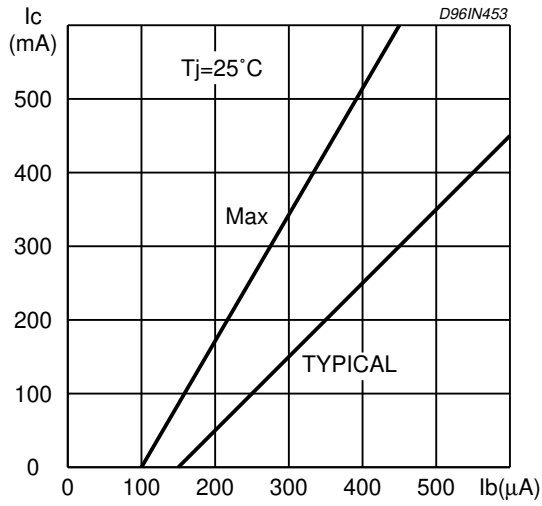

Figure 9: Collector Current versus Saturation Voltage

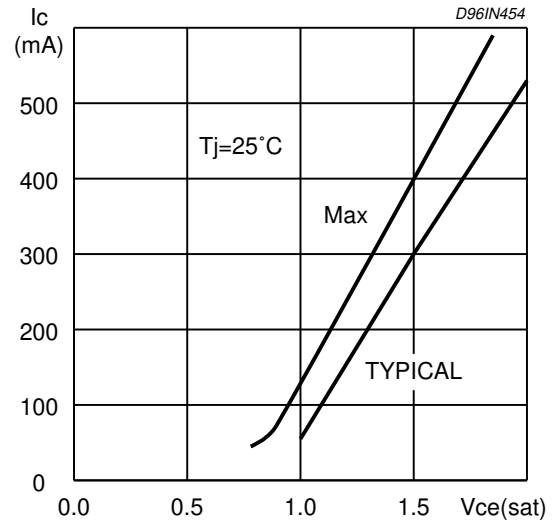

Figure 10: Peak Collector Current versus Duty Cycle

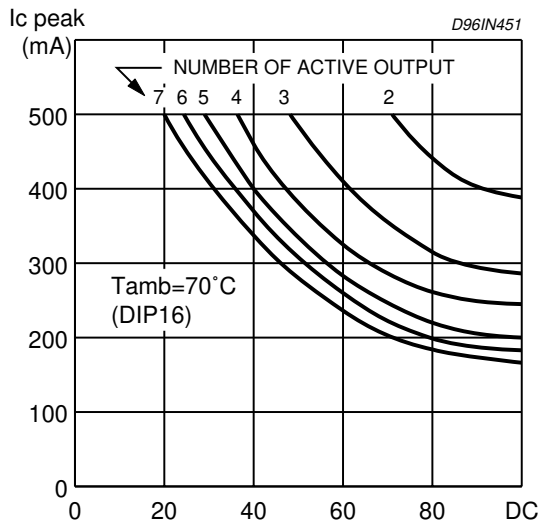
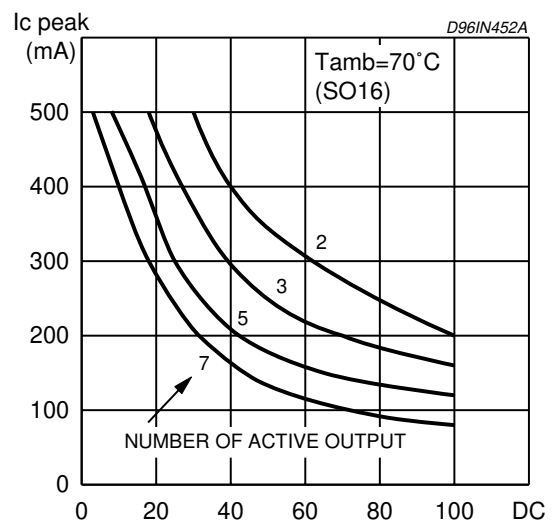

Figure 11: Peak Collector Current versus Duty Cycle



ULN2001A - ULN2002A - ULN2003A - ULN2004A

| DIM. | mm | | | inch | | |
|------|------|-------|------|-------|-------|-------|
| | MIN. | TYP. | MAX. | MIN. | TYP. | MAX. |
| a1 | 0.51 | | | 0.020 | | |
| B | 0.77 | | 1.65 | 0.030 | | 0.065 |
| b | | 0.5 | | | 0.020 | |
| b1 | | 0.25 | | | 0.010 | |
| D | | | 20 | | | 0.787 |
| E | | 8.5 | | | 0.335 | |
| e | | 2.54 | | | 0.100 | |
| e3 | | 17.78 | | | 0.700 | |
| F | | | 7.1 | | | 0.280 |
| I | | | 5.1 | | | 0.201 |
| L | | 3.3 | | | 0.130 | |
| Z | | | 1.27 | | | 0.050 |

OUTLINE AND MECHANICAL DATA

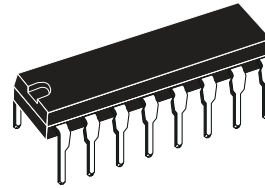

DIP16

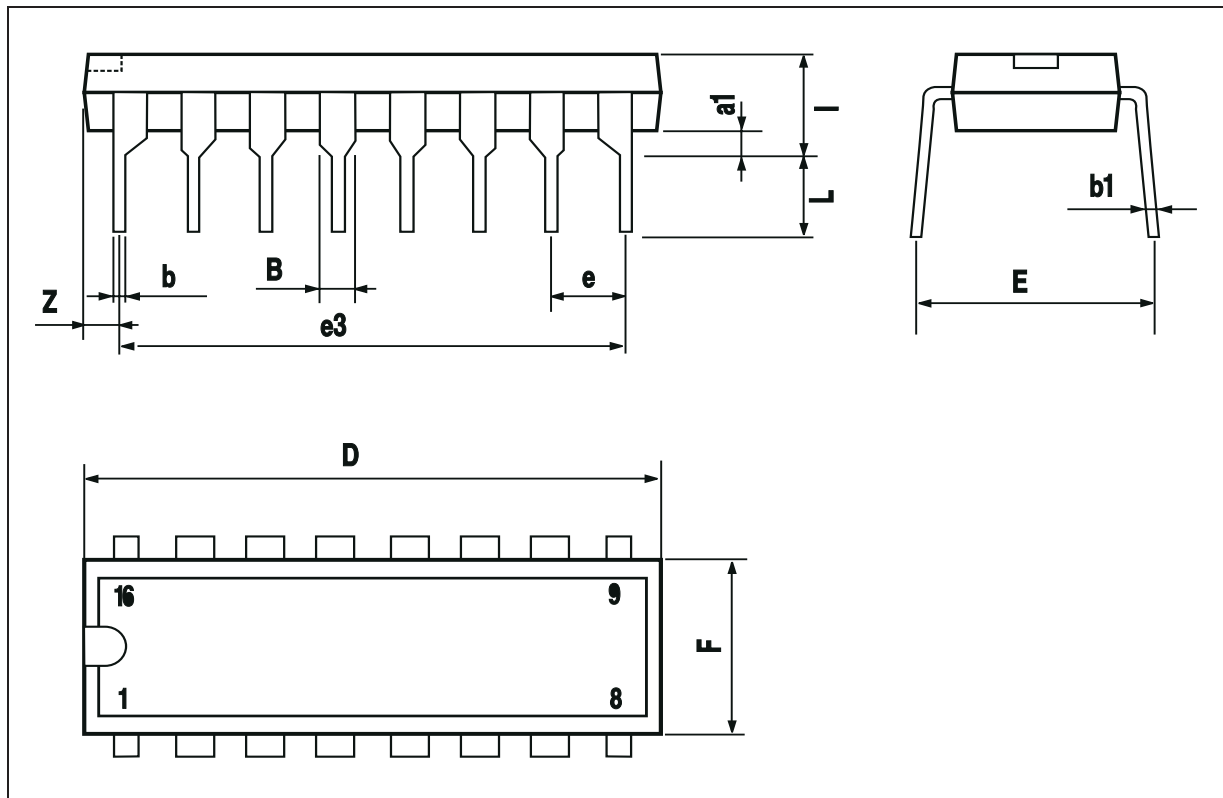

| DIM. | mm | | | inch | | |
|-------|------------|------|------|-------|-------|-------|
| | MIN. | TYP. | MAX. | MIN. | TYP. | MAX. |
| A | | | 1.75 | | | 0.069 |
| a1 | 0.1 | | 0.25 | 0.004 | | 0.009 |
| a2 | | | 1.6 | | | 0.063 |
| b | 0.35 | | 0.46 | 0.014 | | 0.018 |
| b1 | 0.19 | | 0.25 | 0.007 | | 0.010 |
| C | | 0.5 | | | 0.020 | |
| c1 | 45° (typ.) | | | | | |
| D (1) | 9.8 | | 10 | 0.386 | | 0.394 |
| E | 5.8 | | 6.2 | 0.228 | | 0.244 |
| e | | 1.27 | | | 0.050 | |
| e3 | | 8.89 | | | 0.350 | |
| F (1) | 3.8 | | 4 | 0.150 | | 0.157 |
| G | 4.6 | | 5.3 | 0.181 | | 0.209 |
| L | 0.4 | | 1.27 | 0.016 | | 0.050 |
| M | | | 0.62 | | | 0.024 |
| S | 8°(max.) | | | | | |

OUTLINE AND MECHANICAL DATA

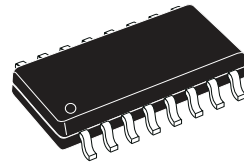

SO16 Narrow

(1) D and F do not include mold flash or protrusions. Mold flash or protrusions shall not exceed 0.15mm (.006inch).

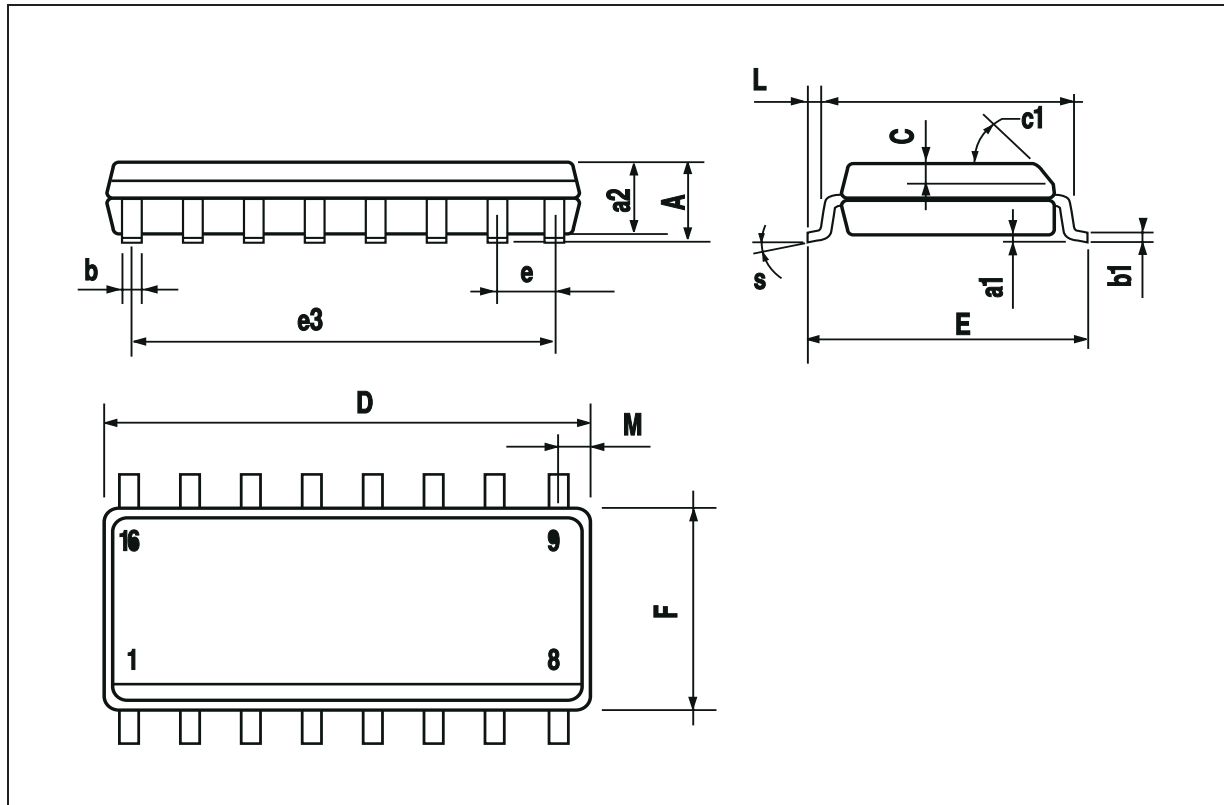

Information furnished is believed to be accurate and reliable. However, STMicroelectronics assumes no responsibility for the consequences of use of such information nor for any infringement of patents or other rights of third parties which may result from its use. No license is granted by implication or otherwise under any patent or patent rights of STMicroelectronics. Specification mentioned in this publication are subject to change without notice. This publication supersedes and replaces all information previously supplied. STMicroelectronics products are not authorized for use as critical components in life support devices or systems without express written approval of STMicroelectronics.

The ST logo is a registered trademark of STMicroelectronics
© 2002 STMicroelectronics – Printed in Italy – All Rights Reserved
STMicroelectronics GROUP OF COMPANIES

Australia - Brazil - Canada - China - Finland - France - Germany - Hong Kong - India - Israel - Italy - Japan - Malaysia - Malta - Morocco -
Singapore - Spain - Sweden - Switzerland - United Kingdom - United States.

<http://www.st.com>

This datasheet has been download from:

www.datasheetcatalog.com

Datasheets for electronics components.