

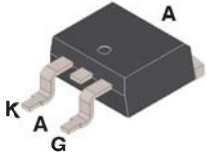
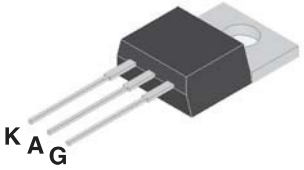
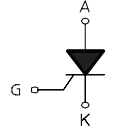

STANDARD 16A SCR

<p>TO-263AB (D2PAK) (FS40xxxG)</p>  <p>TO-220AB (FS40xxxH)</p>  	<p>On-State Current 16 Amp</p>	<p>Gate Trigger Current 2mA to 25mA 2mA to 40mA</p>	
	<p>Off-State Voltage 400 V ÷ 800 V</p>		
	<p>FEATURES</p> <ul style="list-style-type: none"> • Glass/passivated die junctions • Low current SCR • Low thermal resistance • High surge current capability • Low forward voltage drop • Solder dip 260°C, 10s • Component in accordance to RoHS 2011/65/EU and WEEE 2002/96/EC • Meets MSL level 3, per J-STD-020, LF maximum peak of 260° C 		  RoHS COMPLIANT
	<p>MECHANICAL DATA</p> <ul style="list-style-type: none"> • Case: (D2PAK) / (TO-220AB). Epoxy meets UL 94V-0 flammability rating. • Polarity: As marked on the body. • Terminals: Matte tin plated leads, solderable per MIL-STD-750 Method 2026, J-STD-002 and JESD22-B102. Consumer grade, meets JESD 201 class 1A whisker test. 		
<p>TYPICAL APPLICATIONS</p> <p>The standard gate SCR FS1610 and FS1614 series is suitable for a wide range of applications, e.g., Overvoltage Crowbar protection, Motor Control circuits in Power Tools and domestic appliances, inrush current limiting circuits, capacitive discharge ignition and voltage regulation circuits.</p>			

Maximun Ratings and Electrical Characteristics at 25°C

SYMBOL	PARAMETER	CONDITIONS	Value	Unit
$I_{T(RMS)}$	On-state Current	180 ° Conduction Angle, $T_C = 110\text{ °C}$	16	A
$I_{T(AV)}$	Average On-state Current	180 ° Conduction Angle, $T_C = 110\text{ °C}$	10	A
I_{TSM}	Non-repetitive On-State Current	Half Cycle, 60 Hz	200	A
I_{TSM}	Non-repetitive On-State Current	Half Cycle, 50 Hz	190	A
I^2t	Fusing Current	$t_p = 10\text{ ms}$, Half Cycle	180	A ² s
I_{GM}	Peak Gate Current	20 μ s max.	4	A
P_{GM}	Peak Gate Dissipation	20 μ s max.	10	W
$P_{G(AV)}$	Gate Dissipation	20ms max.	1	W
T_j	Operating Temperature		(-40 to +125)	°C
T_{stg}	Storage Temperature		(-40 to +150)	°C
T_{sld}	Soldering Temperature	10s max.	260	°C
V_{RGM}	Max. Peak Reverse Gate Voltage (For FS1610 and FS1614)		5	V

SYMBOL	PARAMETER	VOLTAGE			Unit
		D	M	N	
V_{DRM} V_{RRM}	Repetitive Peak Off State Voltage	400	600	800	V

STANDARD 16A SCR

Electrical Characteristics at Tamb = 25 °C

SYMBOL	PARAMETER	CONDITIONS	SENSITIVITY		Unit	
			10	14		
I _{GT}	Gate Trigger Current	V _D = 12 V _{DC} , R _L = 33Ω.	MIN	2	4	m A
			MAX	25	40	
V _{GT}	Gate Trigger Voltage	V _D = 12 V _{DC} , R _L = 33Ω.	MAX	1.3		V
V _{GD}	Gate Non Trigger Voltage	V _D = V _{DRM} , R _L = 3.3kΩ, T _j = 125 °C	MIN	0.2		V
I _H	Holding Current	I _T = 500 mA,	MAX	40	50	m A
I _L	Latching Current	I _G = 1.2 I _{GT}	MAX	60	90	m A
dV / dt	Critical Rate of Voltage Rise	V _D = 0.67 x V _{DRM} , Gate open T _j = 125 °C	MIN	500	1000	V/μs
dI / dt	Critical Rate of Current Rise	I _G = 2 x I _{GT} Tr ≤ 100 ns, f = 60 Hz, T _j = 125 °C	MIN	50		A/μs
V _{TM}	On-state Voltage	at I _T = 50 Amp, tp = 380 μs, T _j = 25 °C	MAX	1.6		V
V _{TO}	Threshold Voltage	T _j = 125 °C	MAX	0.77		V
r _d	Dynamic resistance	T _j = 125 °C	MAX	23		mΩ.
I _{DRM} / I _{RRM}		V _D = V _{DRM} , V _R = V _{RRM} ,	T _j = 125 °C	MAX	2	mA
			T _j = 25 °C	MAX	5	μA
R _{th(j-c)}	Thermal Resistance Junction-Case for DC	for AC 360 ° conduction angle		1.1		°C/W
R _{th(j-a)}	Thermal Resistance Junction-Amb for DC	S = 1 cm ²	D2PAK	45		°C/W
			TO-220AB	60		

Part Number Information

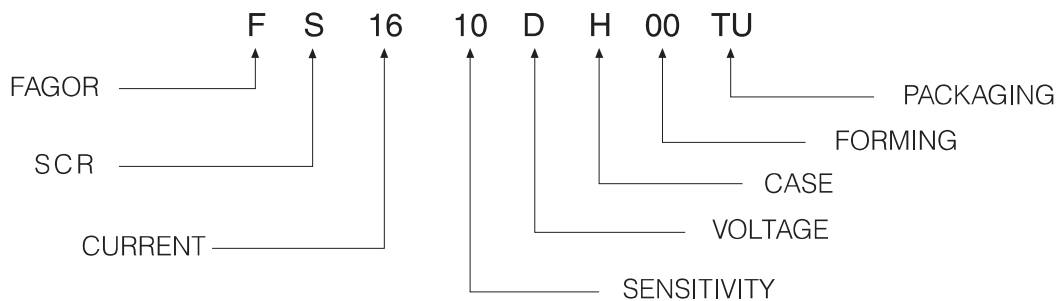

STANDARD 16A SCR

Ordering information

PREFERRED P/N	PACKAGE CODE	DELIVERY MODE	BASE QUANTITY	UNIT WEIGHT (g)
FS1610DG 00TR	TR	13" diameter tape and reel	800	1.50

PREFERRED P/N	PACKAGE CODE	DELIVERY MODE	BASE QUANTITY	UNIT WEIGHT (g)
FS1610DH 00TU	TU	TUBE	1000	2.30

Package Outline Dimensions: (mm) TO-263AB (D2PAK)

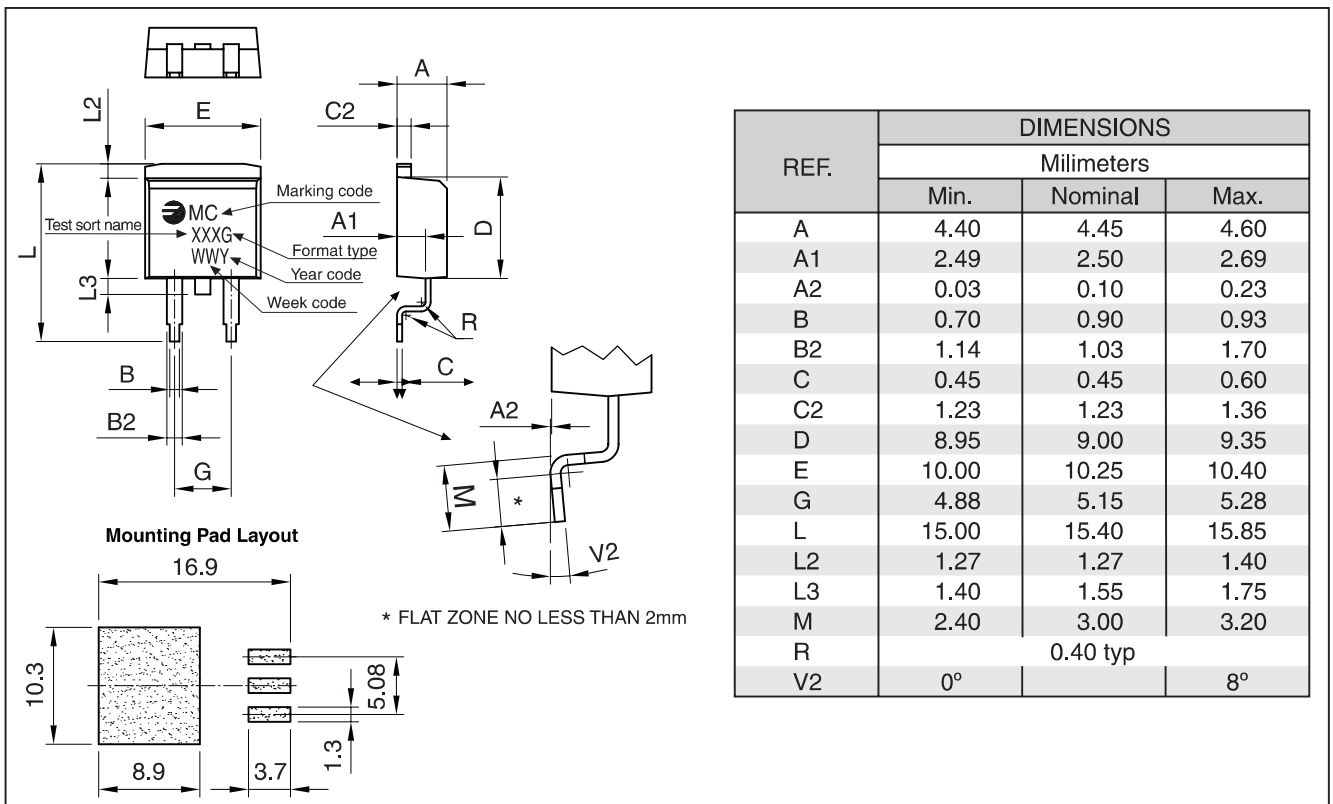

STANDARD 16A SCR

Package Outline Dimensions: (mm) TO-220AB

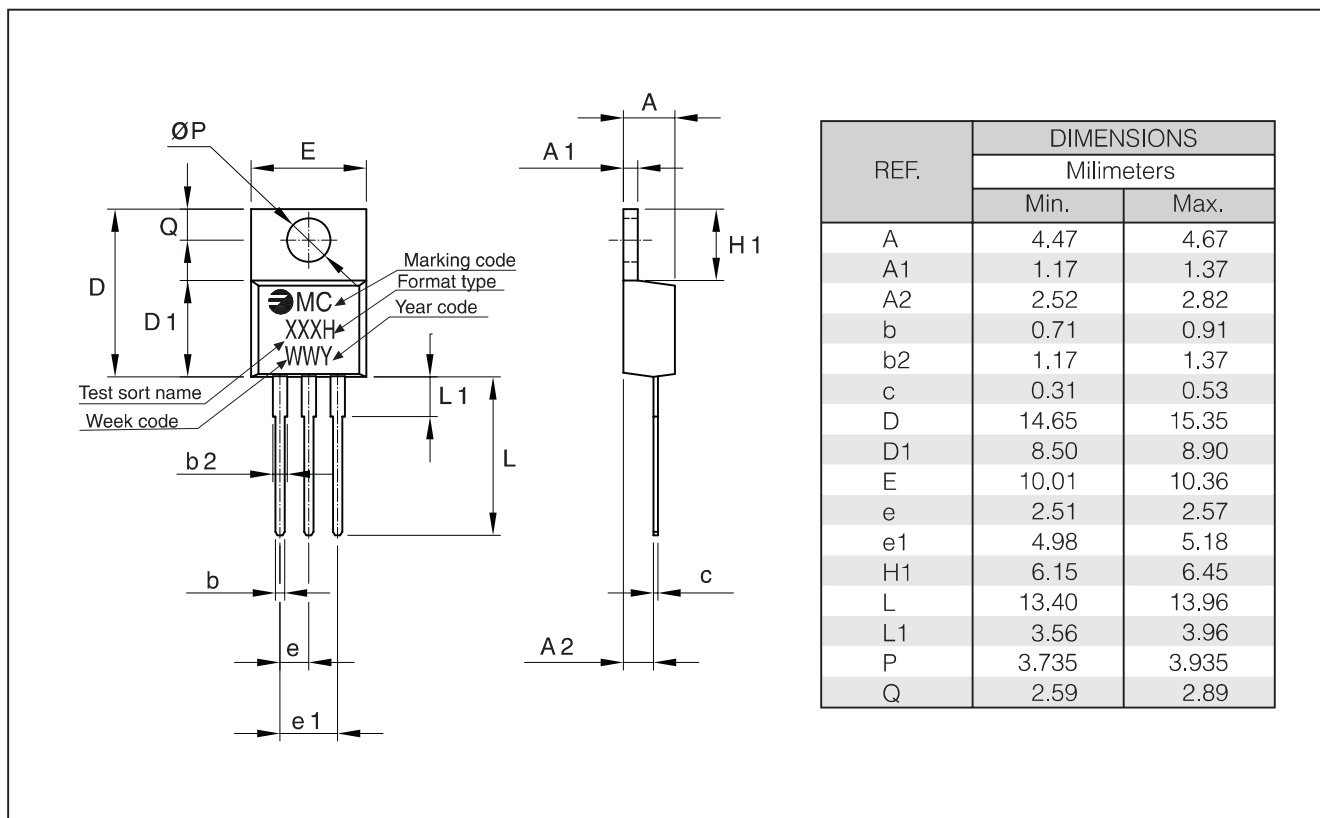

STANDARD 16A SCR

Ratings and Characteristics (Ta 25 °C unless otherwise noted)

Fig. 1: Maximum average power dissipation versus average on-state current.

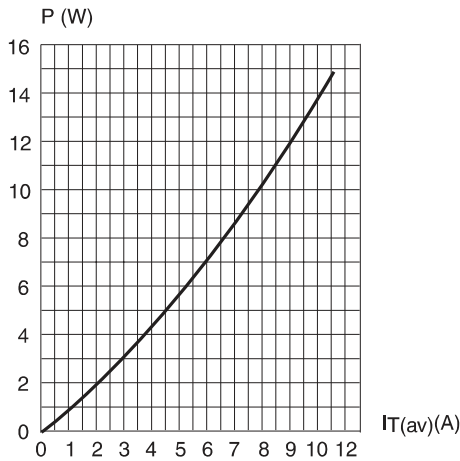

Fig. 2: Average and D.C. on-state current versus case temperature.

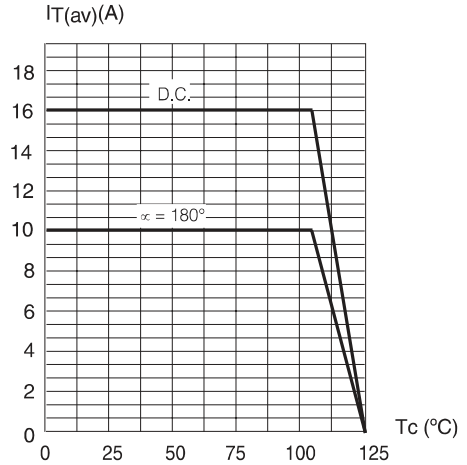

Fig. 3: Relative variation of thermal impedance junction to case versus pulse duration.

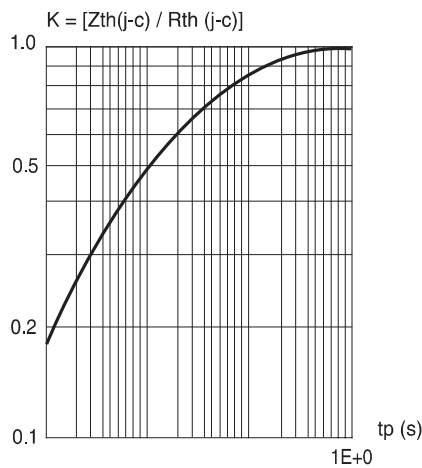

Fig. 4: Relative variation of gate trigger current, holding and latching current versus junction temperature.

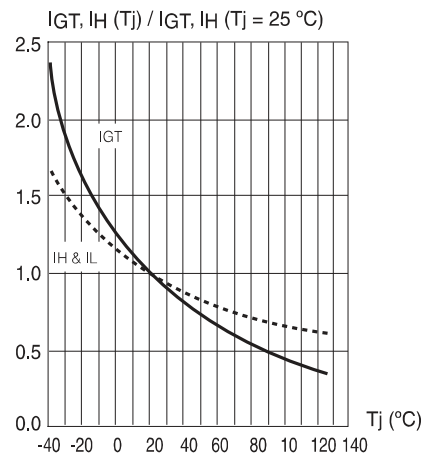

Fig. 5: Non repetitive surge peak on-state current versus number of cycles.

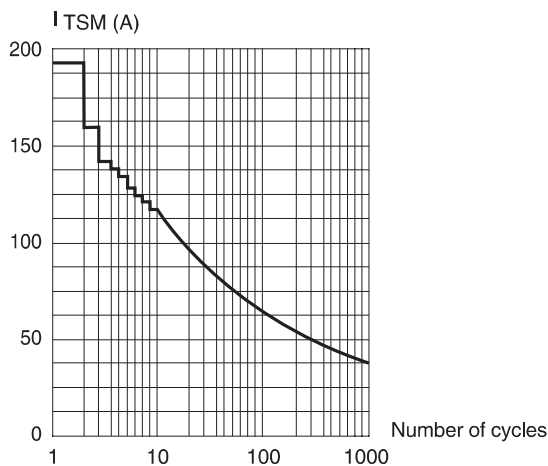
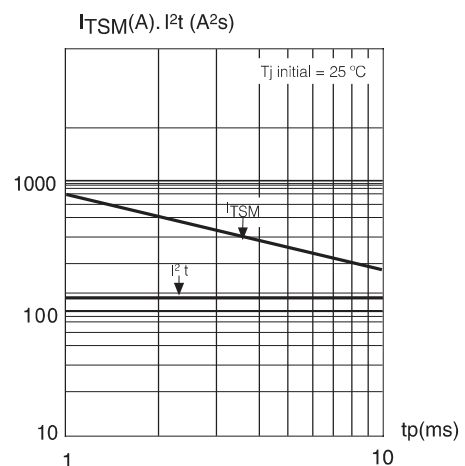

Fig. 6: Non repetitive surge peak on-state current for a sinusoidal pulse with width: $t_p < 10$ ms, and corresponding value of I^2t .



STANDARD 16A SCR

Ratings and Characteristics (Ta 25 °C unless otherwise noted)

Fig. 7: On-state characteristics (maximum values).

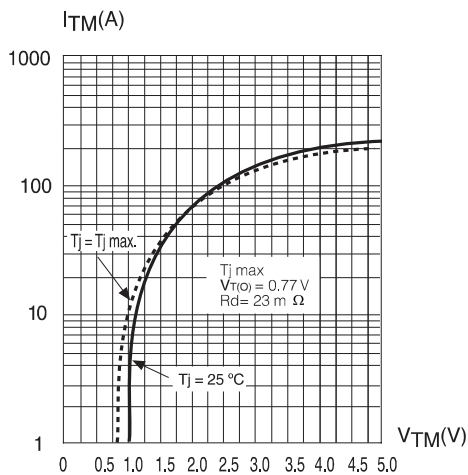

Fig. 8: D²PAK RMS on-state current versus ambient temperature (printed circuit board FR4, copper thickness: 35µm), full cycle.

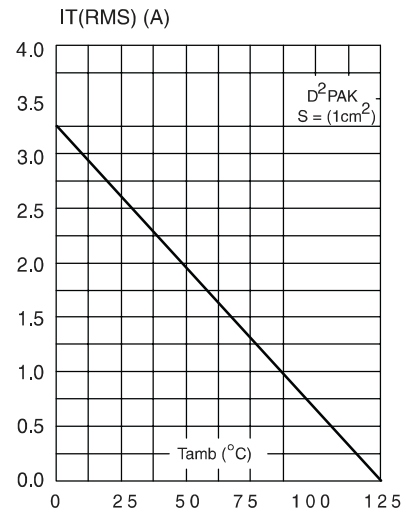
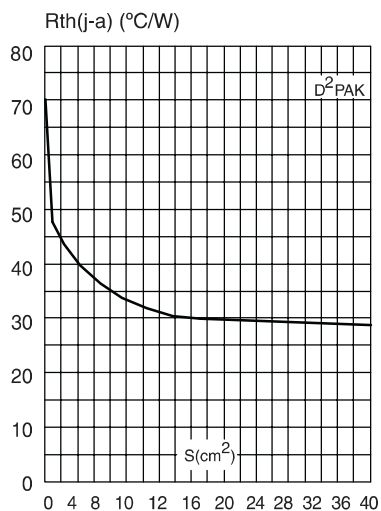

Fig. 9: D²PAK Thermal resistance junction to ambient versus copper surface under tab (printed circuit board FRA, copper thickness: 35µm).



Disclaimer

All product, product specifications and data are subject to change without notice to improve reliability, function or design or otherwise.

Fagor Electrónica, S.Coop., its affiliates, agents, and employees, and all persons acting on its or their behalf (collectively, "Fagor"), disclaim any and all liability for any errors, inaccuracies or incompleteness contained in any datasheet or in any other disclosure relating to any product.

Fagor makes no warranty, representation or guarantee regarding the suitability of the products for any particular purpose or the continuing production of any product. To the maximum extent permitted by applicable law, Fagor disclaims (i) any and all liability arising out of the application or use of any product, (ii) any and all liability, including without limitation special, consequential or incidental damages, and (iii) any and all implied warranties, including warranties of fitness for particular purpose, non-infringement and merchantability.

Statements regarding the suitability of products for certain types of applications are based on Fagor's knowledge of typical requirements that are often placed on Fagor products in generic applications. Such statements are not binding statements about the suitability of products for a particular application. It is the customer's responsibility to validate that a particular product with the properties described in the product specification is suitable for use in a particular application. Parameters provided in datasheets and/or specifications may vary in different applications and performance may vary over time. All operating parameters, including typical parameters, must be validated for each customer application by the customer's technical experts. Product specifications do not expand or otherwise modify Fagor's terms and conditions of purchase, including but not limited to the warranty expressed therein.

Except as expressly indicated in writing, Fagor products are not designed for use in medical, life-saving, or life-sustaining applications or for any other application in which the failure of the Fagor product could result in personal injury or death. Customers using or selling Fagor products not expressly indicated for use in such applications do so at their own risk and agree to fully indemnify and hold Fagor and its distributors harmless from and against any and all claims, liabilities, expenses and damages arising or resulting in connection with such use or sale, including attorneys fees, even if such claim alleges that Fagor or its distributor was negligent regarding the design or manufacture of the part. Please contact authorized Fagor personnel to obtain written terms and conditions regarding products designed for such applications.

No license, express or implied, by estoppel or otherwise, to any intellectual property rights is granted by this document or by any conduct of Fagor, Product names and markings noted herein may be trademarks of their respective owners.