

- 150-mA Load Current Without External Power Transistor
- Adjustable Current-Limiting Capability
- Input Voltages up to 40 V
- Output Adjustable From 2 V to 37 V
- Direct Replacement for Fairchild μA723C

description

The μA723 is a precision integrated-circuit voltage regulator, featuring high ripple rejection, excellent input and load regulation, excellent temperature stability, and low standby current. The circuit consists of a temperature-compensated reference-voltage amplifier, an error amplifier, a 150-mA output transistor, and an adjustable-output current limiter.

The μA723 is designed for use in positive or negative power supplies as a series, shunt, switching, or floating regulator. For output currents exceeding 150 mA, additional pass elements can be connected as shown in Figures 4 and 5.

The μA723C is characterized for operation from 0°C to 70°C.

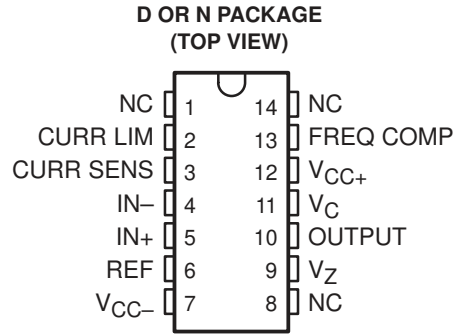

AVAILABLE OPTIONS

T _A	PACKAGED DEVICES		CHIP FORM (Y)
	PLASTIC DIP (N)	SMALL OUTLINE (D)	
0°C to 70°C	μA723CN	μA723CD	μA723Y

The D package is available taped and reeled. Add the suffix R to the device type (e.g., μA723CDR). Chip forms are tested at 25°C.

functional block diagram

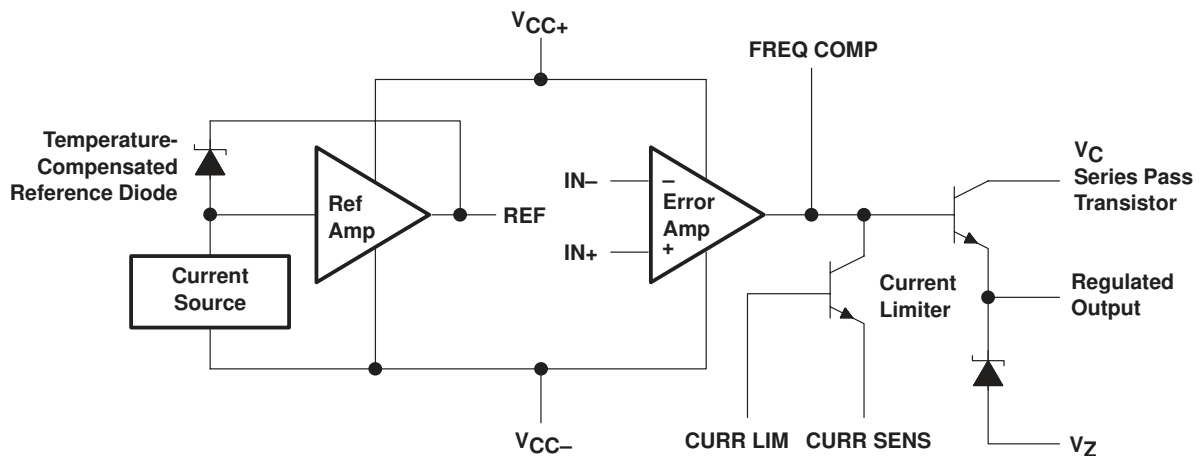

Please be aware that an important notice concerning availability, standard warranty, and use in critical applications of Texas Instruments semiconductor products and disclaimers thereto appears at the end of this data sheet.

PRODUCTION DATA information is current as of publication date. Products conform to specifications per the terms of Texas Instruments standard warranty. Production processing does not necessarily include testing of all parameters.



μA723 PRECISION VOLTAGE REGULATORS

SLVS057D – AUGUST 1972 – REVISED JULY 1999

schematic

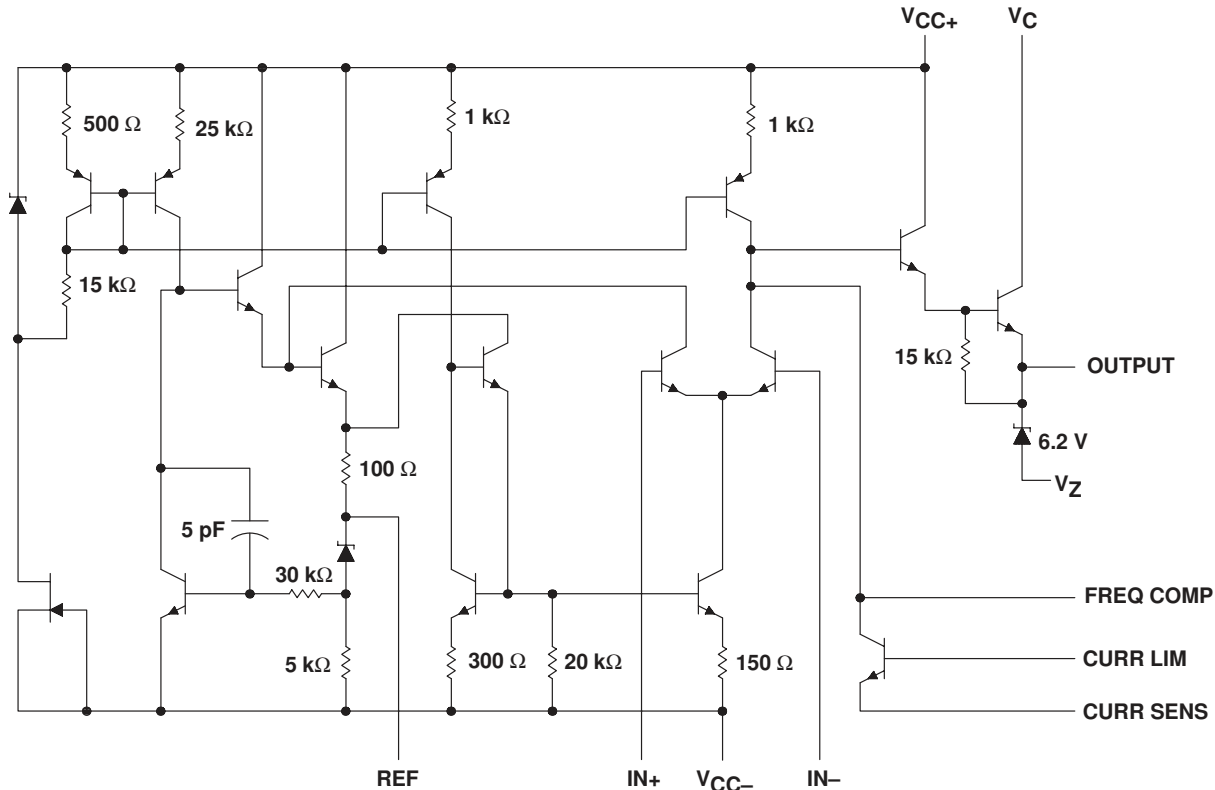

Resistor and capacitor values shown are nominal.

absolute maximum ratings over operating free-air temperature range (unless otherwise noted)[†]

Peak voltage from V_{CC+} to V_{CC-} ($t_w \leq 50$ ms)	50 V
Continuous voltage from V_{CC+} to V_{CC-}	40 V
Input-to-output voltage differential	40 V
Differential input voltage to error amplifier	± 5 V
Voltage between noninverting input and V_{CC-}	8 V
Current from V_Z	25 mA
Current from REF	15 mA
Package thermal impedance, θ_{JA} (see Notes 1 and 2): D package	86°C/W
N package	101°C/W
Lead temperature 1,6 mm (1/16 inch) from case for 10 seconds: D or N package	260°C
Storage temperature range, T_{stg}	-65°C to 150°C

[†] Stresses beyond those listed under "absolute maximum ratings" may cause permanent damage to the device. These are stress ratings only, and functional operation of the device at these or any other conditions beyond those indicated under "recommended operating conditions" is not implied. Exposure to absolute-maximum-rated conditions for extended periods may affect device reliability.

NOTES: 1. Maximum power dissipation is a function of $T_J(\max)$, θ_{JA} , and T_A . The maximum allowable power dissipation at any allowable ambient temperature is $P_D = (T_J(\max) - T_A)/\theta_{JA}$. Operating at the absolute maximum T_J of 150°C can impact reliability.
2. The package thermal impedance is calculated in accordance with JESD 51, except for through-hole packages, which use a trace length of zero.

recommended operating conditions

	MIN	MAX	UNIT
Input voltage, V_I	9.5	40	V
Output voltage, V_O	2	37	V
Input-to-output voltage differential, $V_C - V_O$	3	38	V
Output current, I_O		150	mA
Operating free-air temperature range, T_A	μA723C		0 70 °C

electrical characteristics at specified free-air temperature (see Notes 3 and 4)

PARAMETER	TEST CONDITIONS	T_A	μA723C			UNIT
			MIN	TYP	MAX	
Input regulation	$V_I = 12\text{ V to }V_I = 15\text{ V}$	25°C		0.1	1	mV/V
	$V_I = 12\text{ V to }V_I = 40\text{ V}$	25°C		1	5	
	$V_I = 12\text{ V to }V_I = 15\text{ V}$	0°C to 70°C			3	
Ripple rejection	f = 50 Hz to 10 kHz, $C_{ref} = 0$	25°C		74		dB
	f = 50 Hz to 10 kHz, $C_{ref} = 5\text{ }\mu\text{F}$	25°C		86		
Output regulation		25°C		-0.3	-2	mV/V
		0°C to 70°C			-6	
Reference voltage, V_{ref}		25°C	6.8	7.15	7.5	V
Standby current	$V_I = 30\text{ V}, I_O = 0$	25°C		2.3	4	mA
Temperature coefficient of output voltage		0°C to 70°C		0.003	0.015	%/°C
Short-circuit output current	$R_{SC} = 10\text{ }\Omega, V_O = 0$	25°C		65		mA
Output noise voltage	BW = 100 Hz to 10 kHz, $C_{ref} = 0$	25°C		20		μV
	BW = 100 Hz to 10 kHz, $C_{ref} = 5\text{ }\mu\text{F}$	25°C		2.5		

- NOTES: 3. For all values in this table, the device is connected as shown in Figure 1 with the divider resistance as seen by the error amplifier $\leq 10\text{ k}\Omega$. Unless otherwise specified, $V_I = V_{CC+} = V_C = 12\text{ V}$, $V_{CC-} = 0$, $V_O = 5\text{ V}$, $I_O = 1\text{ mA}$, $R_{SC} = 0$, and $C_{ref} = 0$.
4. Pulse-testing techniques must be used that will maintain the junction temperature as close to the ambient temperature as possible.

electrical characteristics, $T_A = 25^\circ\text{C}$ (see Notes 3 and 4)

PARAMETER	TEST CONDITIONS	μA723Y			UNIT
		MIN	TYP	MAX	
Input regulation	$V_I = 12\text{ V to }V_I = 15\text{ V}$		0.1		mV/V
	$V_I = 12\text{ V to }V_I = 40\text{ V}$		1		
Ripple rejection	f = 50 Hz to 10 kHz, $C_{ref} = 0$		74		dB
	f = 50 Hz to 10 kHz, $C_{ref} = 5\text{ }\mu\text{F}$		86		
Output regulation			-0.3		mV/V
Reference voltage, V_{ref}			7.15		V
Standby current	$V_I = 30\text{ V}, I_O = 0$		2.3		mA
Short-circuit output current	$R_{SC} = 10\text{ }\Omega, V_O = 0$		65		mA
Output noise voltage	BW = 100 Hz to 10 kHz, $C_{ref} = 0$		20		μV
	BW = 100 Hz to 10 kHz, $C_{ref} = 5\text{ }\mu\text{F}$		2.5		

- NOTES: 3. For all values in this table, the device is connected as shown in Figure 1 with the divider resistance as seen by the error amplifier $\leq 10\text{ k}\Omega$. Unless otherwise specified, $V_I = V_{CC+} = V_C = 12\text{ V}$, $V_{CC-} = 0$, $V_O = 5\text{ V}$, $I_O = 1\text{ mA}$, $R_{SC} = 0$, and $C_{ref} = 0$.
4. Pulse-testing techniques must be used that will maintain the junction temperature as close to the ambient temperature as possible.

APPLICATION INFORMATION

Table 1. Resistor Values (kΩ) for Standard Output Voltages

OUTPUT VOLTAGE (V)	APPLICABLE FIGURES (SEE NOTE 5)	FIXED OUTPUT ±5%		OUTPUT ADJUSTABLE ±10% (SEE NOTE 6)		
		R1 (kΩ)	R2 (kΩ)	R1 (kΩ)	P1 (kΩ)	P2 (kΩ)
3.0	1, 5, 6, 9, 11, 12 (4)	4.12	3.01	1.8	0.5	1.2
3.6	1, 5, 6, 9, 11, 12 (4)	3.57	3.65	1.5	0.5	1.5
5.0	1, 5, 6, 9, 11, 12 (4)	2.15	4.99	0.75	0.5	2.2
6.0	1, 5, 6, 9, 11, 12 (4)	1.15	6.04	0.5	0.5	2.7
9.0	2, 4, (5, 6, 9, 12)	1.87	7.15	0.75	1.0	2.7
12	2, 4, (5, 6, 9, 12)	4.87	7.15	2.0	1.0	3.0
15	2, 4, (5, 6, 9, 12)	7.87	7.15	3.3	1.0	3.0
28	2, 4, (5, 6, 9, 12)	21.0	7.15	5.6	1.0	2.0
45	7	3.57	48.7	2.2	10	39
75	7	3.57	78.7	2.2	10	68
100	7	3.57	105	2.2	10	91
250	7	3.57	255	2.2	10	240
-6 (see Note 7)	3, 10	3.57	2.43	1.2	0.5	0.75
-9	3, 10	3.48	5.36	1.2	0.5	2.0
-12	3, 10	3.57	8.45	1.2	0.5	3.3
-15	3, 10	3.57	11.5	1.2	0.5	4.3
-28	3, 10	3.57	24.3	1.2	0.5	10
-45	8	3.57	41.2	2.2	10	33
-100	8	3.57	95.3	2.2	10	91
-250	8	3.57	249	2.2	10	240

- NOTES: 5. The R1/R2 divider can be across either V_O or $V_{(ref)}$. If the divider is across $V_{(ref)}$, use the figure numbers without parentheses. If the divider is across V_O , use the figure numbers in parentheses.
 6. To make the voltage adjustable, the R1/R2 divider shown in the figures must be replaced by the divider shown below.

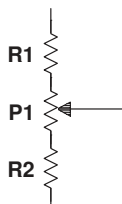

Adjustable Output Circuit

7. For Figures 3, 8, and 10, the device requires a minimum of 9V between V_{CC+} and V_{CC-} when V_O is equal to or more positive than -9 V.

APPLICATION INFORMATION

Table 2. Formulas for Intermediate Output Voltages

OUTPUTS FROM 2 V TO 7 V SEE FIGURES 1, 5, 6, 9, 11, 12 (4) AND NOTE 5	OUTPUTS FROM 4 V TO 250 V SEE FIGURE 7 AND NOTE 5	CURRENT LIMITING
$V_O = V_{(ref)} \times \frac{R_2}{R_1 + R_2}$	$V_O = \frac{V_{(ref)}}{2} \times \frac{R_2 - R_1}{R_1}$ $R_3 = R_4$	$I_{(limit)} \approx \frac{0.65 \text{ V}}{R_{SC}}$
OUTPUTS FROM 7 V TO 37 V SEE FIGURES 2, 4, (5, 6, 9, 11, 12) AND NOTE 5	OUTPUTS FROM -6 V TO -250 V SEE FIGURES 3, 8, 10 AND NOTES 5 AND 7	FOLDBACK CURRENT LIMITING SEE FIGURE 6
$V_O = V_{(ref)} \times \frac{R_1 + R_2}{R_2}$	$V_O = -\frac{V_{(ref)}}{2} \times \frac{R_1 + R_2}{R_1}$ $R_3 = R_4$	$I_{(knee)} \approx \frac{V_O R_3 + (R_3 + R_4) 0.65 \text{ V}}{R_{SC} R_4}$ $I_{OS} \approx \frac{0.65 \text{ V}}{R_{SC}} \times \frac{R_3 + R_4}{R_4}$

- NOTES: 5. The R1/R2 divider can be across either V_O or $V_{(ref)}$. If the divider is across $V_{(ref)}$, use figure numbers without parentheses. If the divider is across V_O , use the figure numbers in parentheses.
7. For Figures 3, 8, and 10, the device requires a minimum of 9 V between V_{CC+} and V_{CC-} when V_O is equal to or more positive than -9 V.

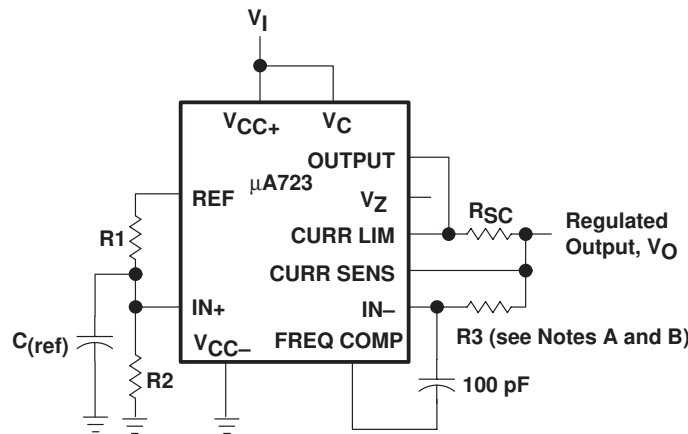

- NOTES: A. $R_3 = \frac{R_1 \times R_2}{R_1 + R_2}$ for a minimum α_{V_O}
- B. R_3 can be eliminated for minimum component count. Use direct connection (i.e., $R_3 = 0$).

Figure 1. Basic Low-Voltage Regulator ($V_O = 2 \text{ V to } 7 \text{ V}$)

APPLICATION INFORMATION

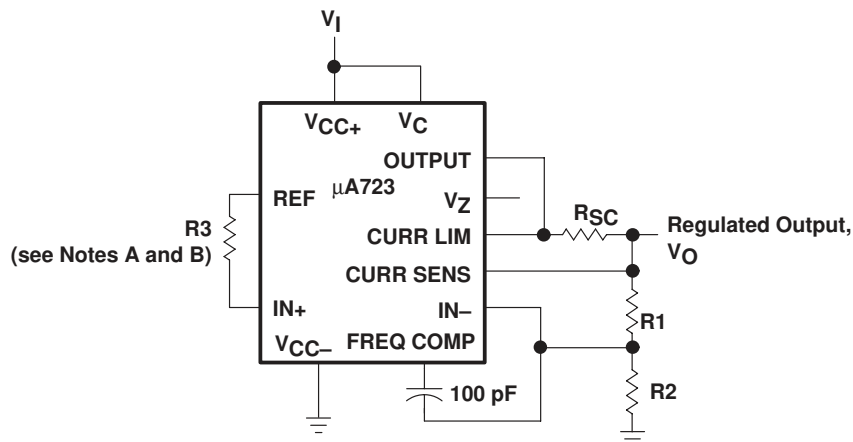

- NOTES: A. $R_3 = \frac{R_1 \times R_2}{R_1 + R_2}$ for a minimum α_{V_O}
 B. R_3 can be eliminated for minimum component count. Use direct connection (i.e., $R_3 = 0$).

Figure 2. Basic High-Voltage Regulator ($V_O = 7\text{ V to }37\text{ V}$)

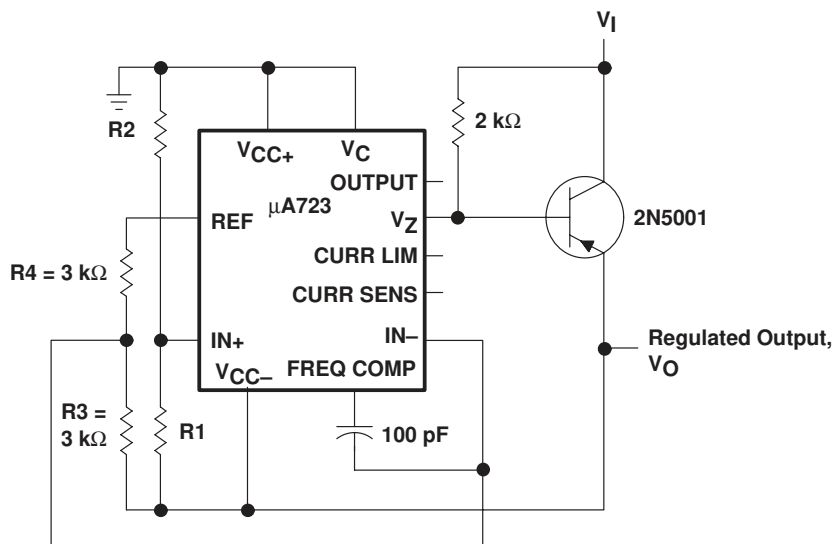

Figure 3. Negative-Voltage Regulator

APPLICATION INFORMATION

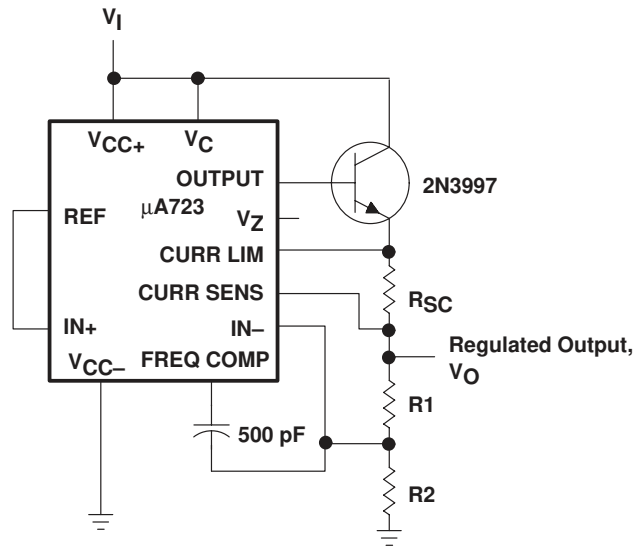

Figure 4. Positive-Voltage Regulator (External npn Pass Transistor)

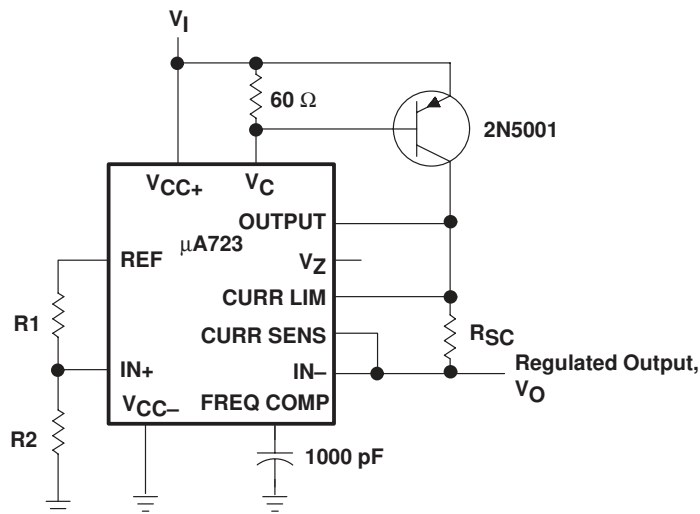

Figure 5. Positive-Voltage Regulator (External pnp Pass Transistor)

APPLICATION INFORMATION

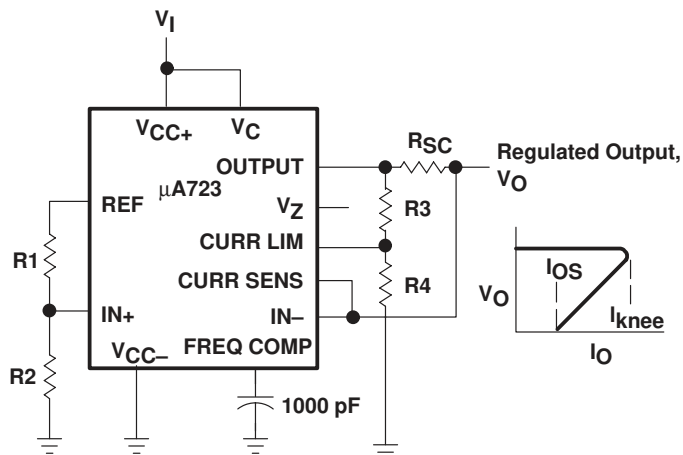

Figure 6. Foldback Current Limiting

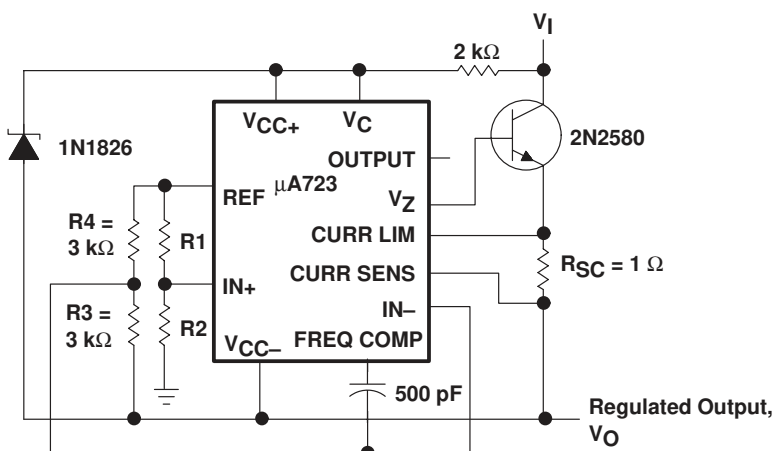

Figure 7. Positive Floating Regulator

APPLICATION INFORMATION

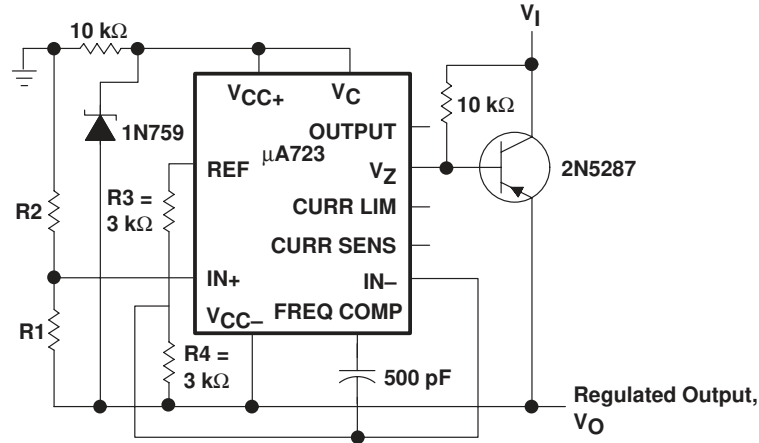
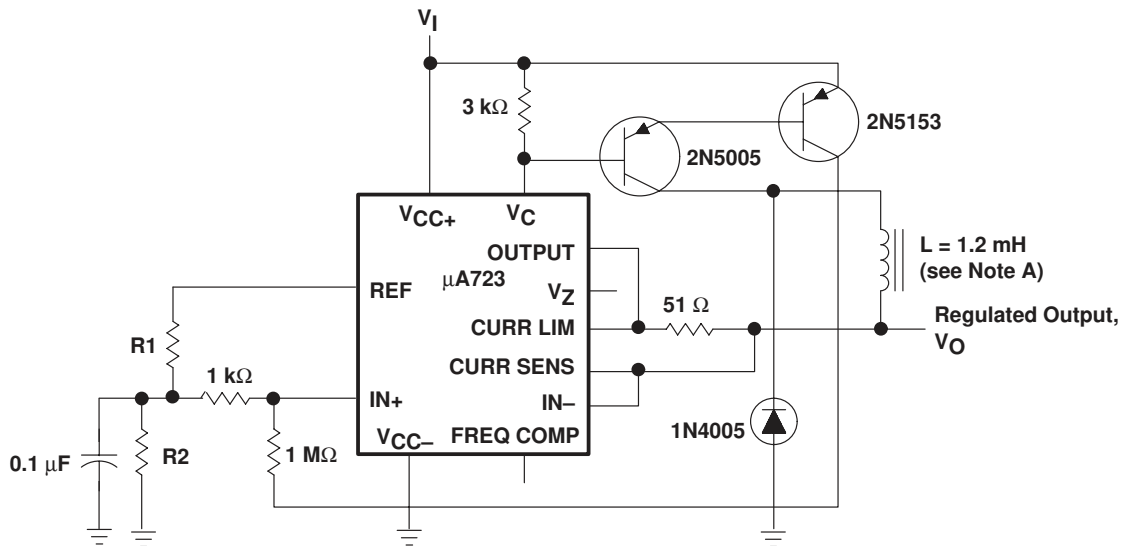

Figure 8. Negative Floating Regulator



NOTE A: L is 40 turns of No. 20 enameled copper wire wound on Ferroxcube P36/22-3B7 potted core, or equivalent, with a 0.009-inch air gap.

Figure 9. Positive Switching Regulator

APPLICATION INFORMATION

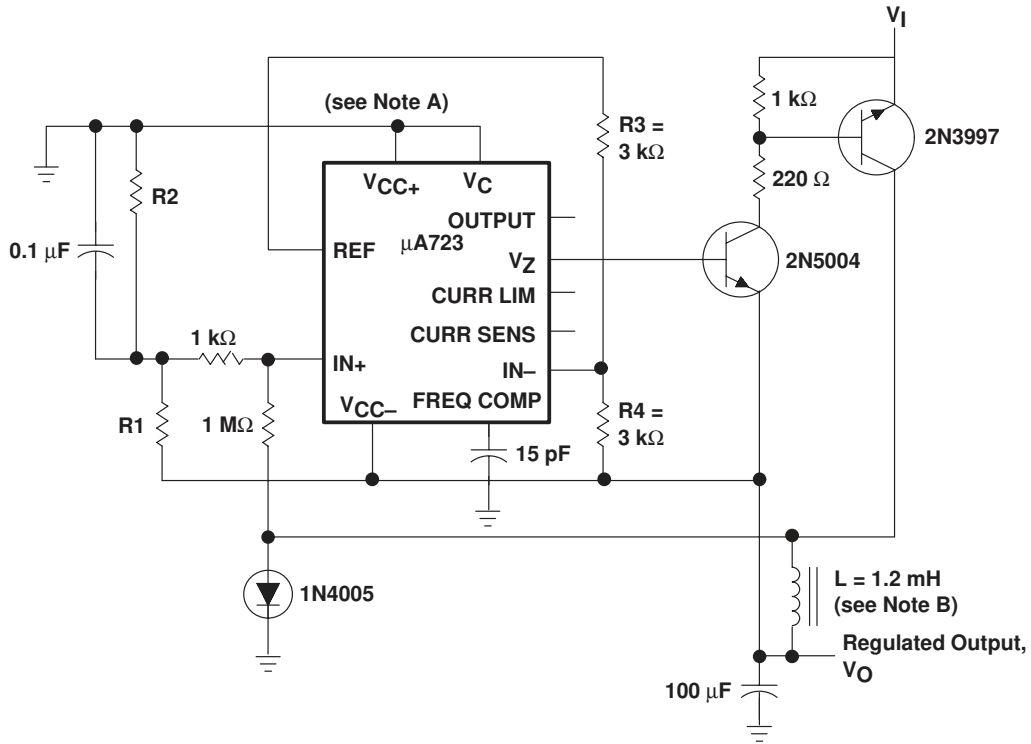

- NOTES: A. The device requires a minimum of 9 V between V_{CC+} and V_{CC-} when V_O is equal to or more positive than -9 V.
 B. L is 40 turns of No. 20 enameled copper wire wound on Ferroxcube P36/22-3B7 potted core, or equivalent, with a 0.009-inch air gap.

Figure 10. Negative Switching Regulator

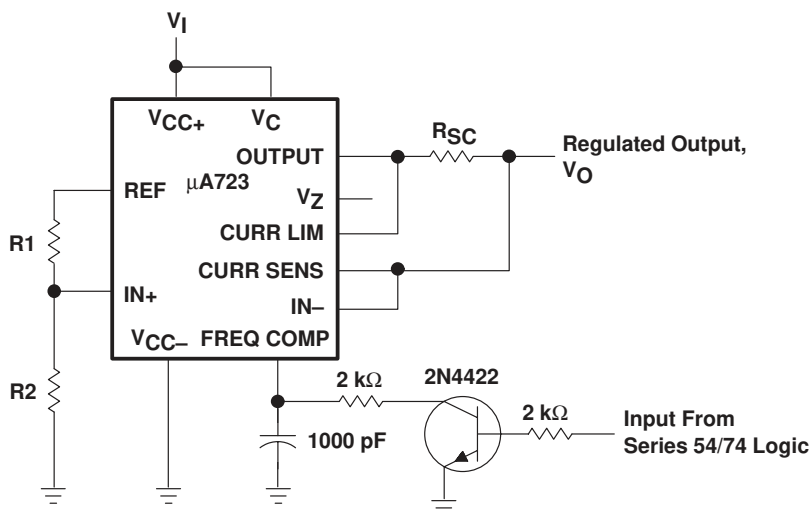

NOTE A: A current-limiting transistor can be used for shutdown if current limiting is not required.

Figure 11. Remote Shutdown Regulator With Current Limiting

APPLICATION INFORMATION

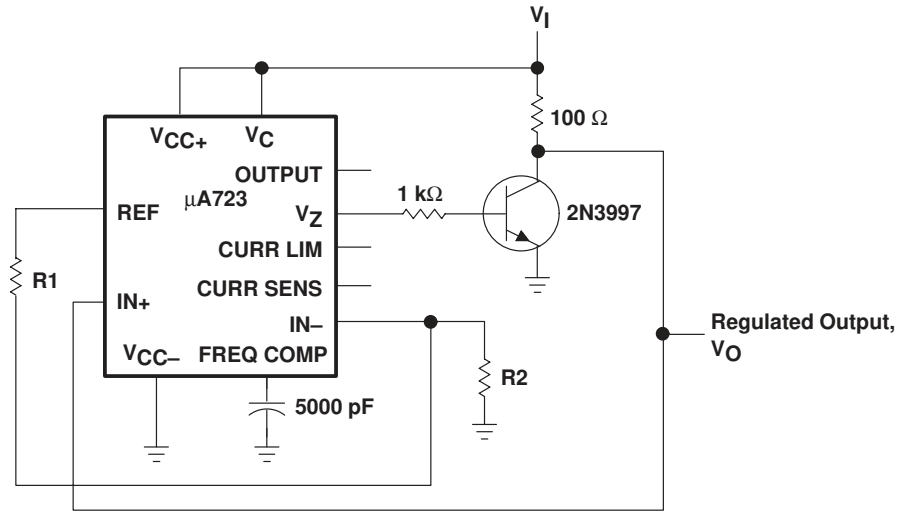

Figure 12. Shunt Regulator

PACKAGING INFORMATION

Orderable Device	Status (1)	Package Type	Package Drawing	Pins	Package Qty	Eco Plan (2)	Lead/Ball Finish (6)	MSL Peak Temp (3)	Op Temp (°C)	Device Marking (4/5)	Samples
UA723CD	ACTIVE	SOIC	D	14	50	Green (RoHS & no Sb/Br)	NIPDAU	Level-1-260C-UNLIM	0 to 70	UA723C	Samples
UA723CDE4	ACTIVE	SOIC	D	14	50	Green (RoHS & no Sb/Br)	NIPDAU	Level-1-260C-UNLIM	0 to 70	UA723C	Samples
UA723CDR	ACTIVE	SOIC	D	14	2500	Green (RoHS & no Sb/Br)	NIPDAU	Level-1-260C-UNLIM	0 to 70	UA723C	Samples
UA723CDRE4	ACTIVE	SOIC	D	14	2500	Green (RoHS & no Sb/Br)	NIPDAU	Level-1-260C-UNLIM	0 to 70	UA723C	Samples
UA723CDRG4	ACTIVE	SOIC	D	14	2500	Green (RoHS & no Sb/Br)	NIPDAU	Level-1-260C-UNLIM	0 to 70	UA723C	Samples
UA723CN	ACTIVE	PDIP	N	14	25	Green (RoHS & no Sb/Br)	NIPDAU	N / A for Pkg Type	0 to 70	UA723CN	Samples
UA723CNE4	ACTIVE	PDIP	N	14	25	Green (RoHS & no Sb/Br)	NIPDAU	N / A for Pkg Type	0 to 70	UA723CN	Samples
UA723CNSR	ACTIVE	SO	NS	14	2000	Green (RoHS & no Sb/Br)	NIPDAU	Level-1-260C-UNLIM	0 to 70	UA723	Samples

(1) The marketing status values are defined as follows:

ACTIVE: Product device recommended for new designs.

LIFEBUY: TI has announced that the device will be discontinued, and a lifetime-buy period is in effect.

NRND: Not recommended for new designs. Device is in production to support existing customers, but TI does not recommend using this part in a new design.

PREVIEW: Device has been announced but is not in production. Samples may or may not be available.

OBsolete: TI has discontinued the production of the device.

(2) **RoHS:** TI defines "RoHS" to mean semiconductor products that are compliant with the current EU RoHS requirements for all 10 RoHS substances, including the requirement that RoHS substance do not exceed 0.1% by weight in homogeneous materials. Where designed to be soldered at high temperatures, "RoHS" products are suitable for use in specified lead-free processes. TI may reference these types of products as "Pb-Free".

RoHS Exempt: TI defines "RoHS Exempt" to mean products that contain lead but are compliant with EU RoHS pursuant to a specific EU RoHS exemption.

Green: TI defines "Green" to mean the content of Chlorine (Cl) and Bromine (Br) based flame retardants meet JS709B low halogen requirements of <=1000ppm threshold. Antimony trioxide based flame retardants must also meet the <=1000ppm threshold requirement.

(3) MSL, Peak Temp. - The Moisture Sensitivity Level rating according to the JEDEC industry standard classifications, and peak solder temperature.

(4) There may be additional marking, which relates to the logo, the lot trace code information, or the environmental category on the device.

⁽⁵⁾ Multiple Device Markings will be inside parentheses. Only one Device Marking contained in parentheses and separated by a "~" will appear on a device. If a line is indented then it is a continuation of the previous line and the two combined represent the entire Device Marking for that device.

⁽⁶⁾ Lead/Ball Finish - Orderable Devices may have multiple material finish options. Finish options are separated by a vertical ruled line. Lead/Ball Finish values may wrap to two lines if the finish value exceeds the maximum column width.

Important Information and Disclaimer:The information provided on this page represents TI's knowledge and belief as of the date that it is provided. TI bases its knowledge and belief on information provided by third parties, and makes no representation or warranty as to the accuracy of such information. Efforts are underway to better integrate information from third parties. TI has taken and continues to take reasonable steps to provide representative and accurate information but may not have conducted destructive testing or chemical analysis on incoming materials and chemicals. TI and TI suppliers consider certain information to be proprietary, and thus CAS numbers and other limited information may not be available for release.

In no event shall TI's liability arising out of such information exceed the total purchase price of the TI part(s) at issue in this document sold by TI to Customer on an annual basis.

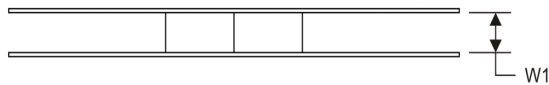
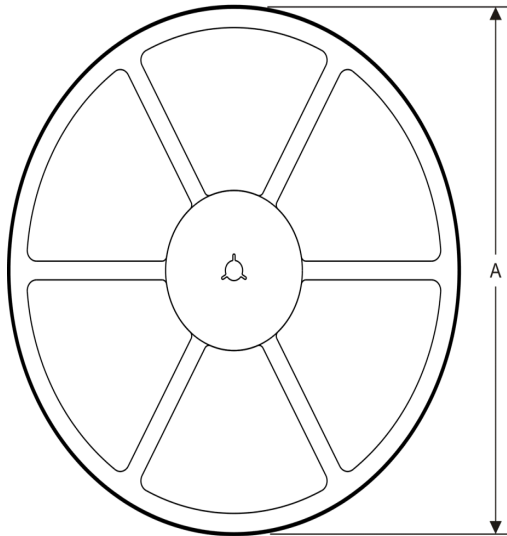
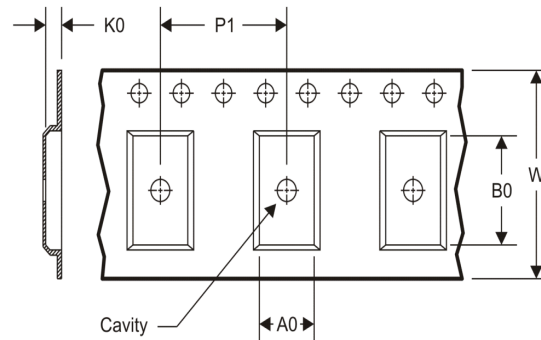
TAPE AND REEL INFORMATION
REEL DIMENSIONS

TAPE DIMENSIONS

A0	Dimension designed to accommodate the component width
B0	Dimension designed to accommodate the component length
K0	Dimension designed to accommodate the component thickness
W	Overall width of the carrier tape
P1	Pitch between successive cavity centers

TAPE AND REEL INFORMATION

*All dimensions are nominal

Device	Package Type	Package Drawing	Pins	SPQ	Reel Diameter (mm)	Reel Width W1 (mm)	A0 (mm)	B0 (mm)	K0 (mm)	P1 (mm)	W (mm)	Pin1 Quadrant
UA723CDR	SOIC	D	14	2500	330.0	16.4	6.5	9.0	2.1	8.0	16.0	Q1
UA723CNSR	SO	NS	14	2000	330.0	16.4	8.2	10.5	2.5	12.0	16.0	Q1

TAPE AND REEL BOX DIMENSIONS

*All dimensions are nominal

Device	Package Type	Package Drawing	Pins	SPQ	Length (mm)	Width (mm)	Height (mm)
UA723CDR	SOIC	D	14	2500	367.0	367.0	38.0
UA723CNSR	SO	NS	14	2000	367.0	367.0	38.0

MECHANICAL DATA

NS (R-PDSO-G**)

PLASTIC SMALL-OUTLINE PACKAGE

14-PINS SHOWN

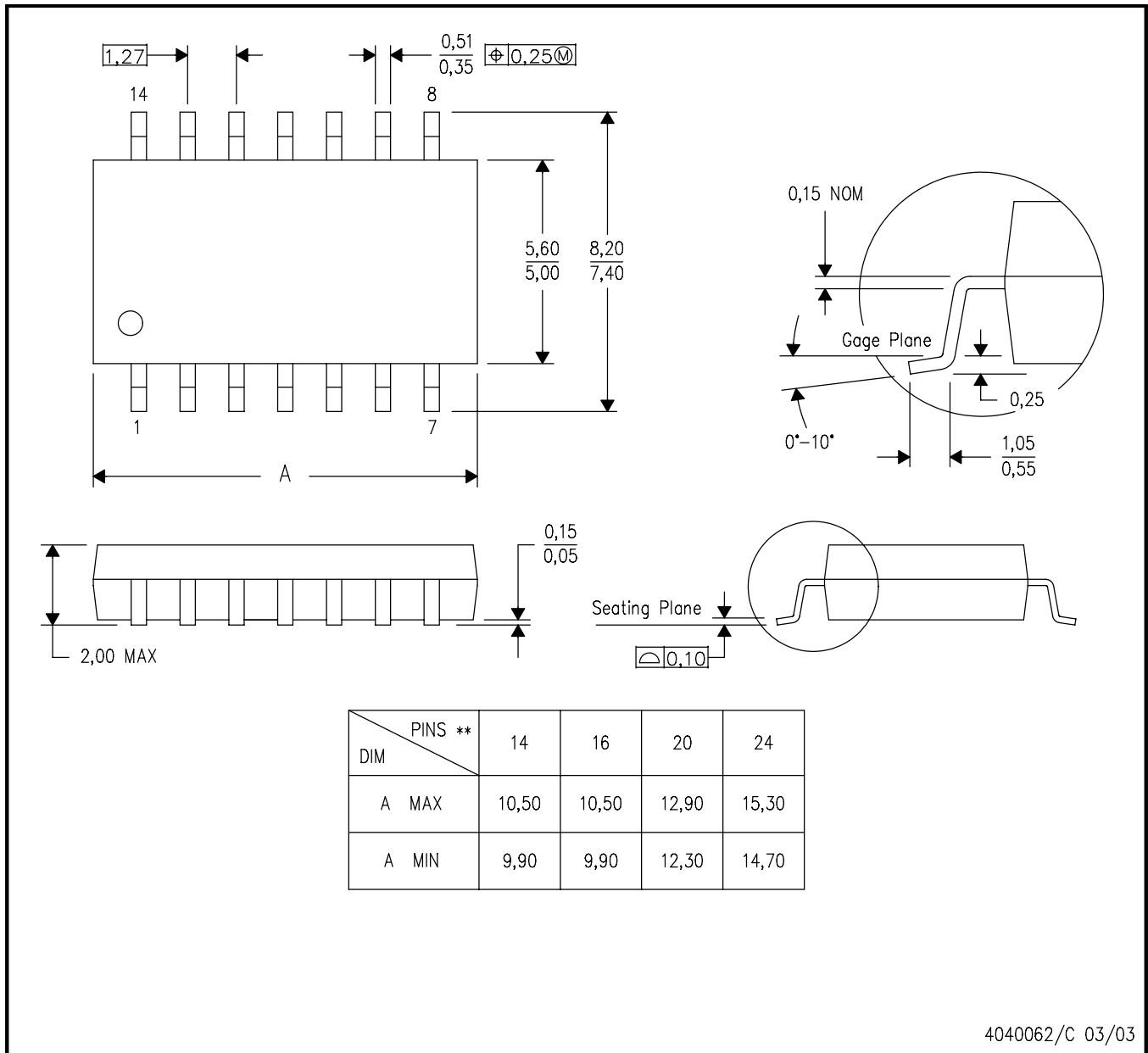

- NOTES:
- A. All linear dimensions are in millimeters.
 - B. This drawing is subject to change without notice.
 - C. Body dimensions do not include mold flash or protrusion, not to exceed 0,15.

D (R-PDSO-G14)

PLASTIC SMALL OUTLINE

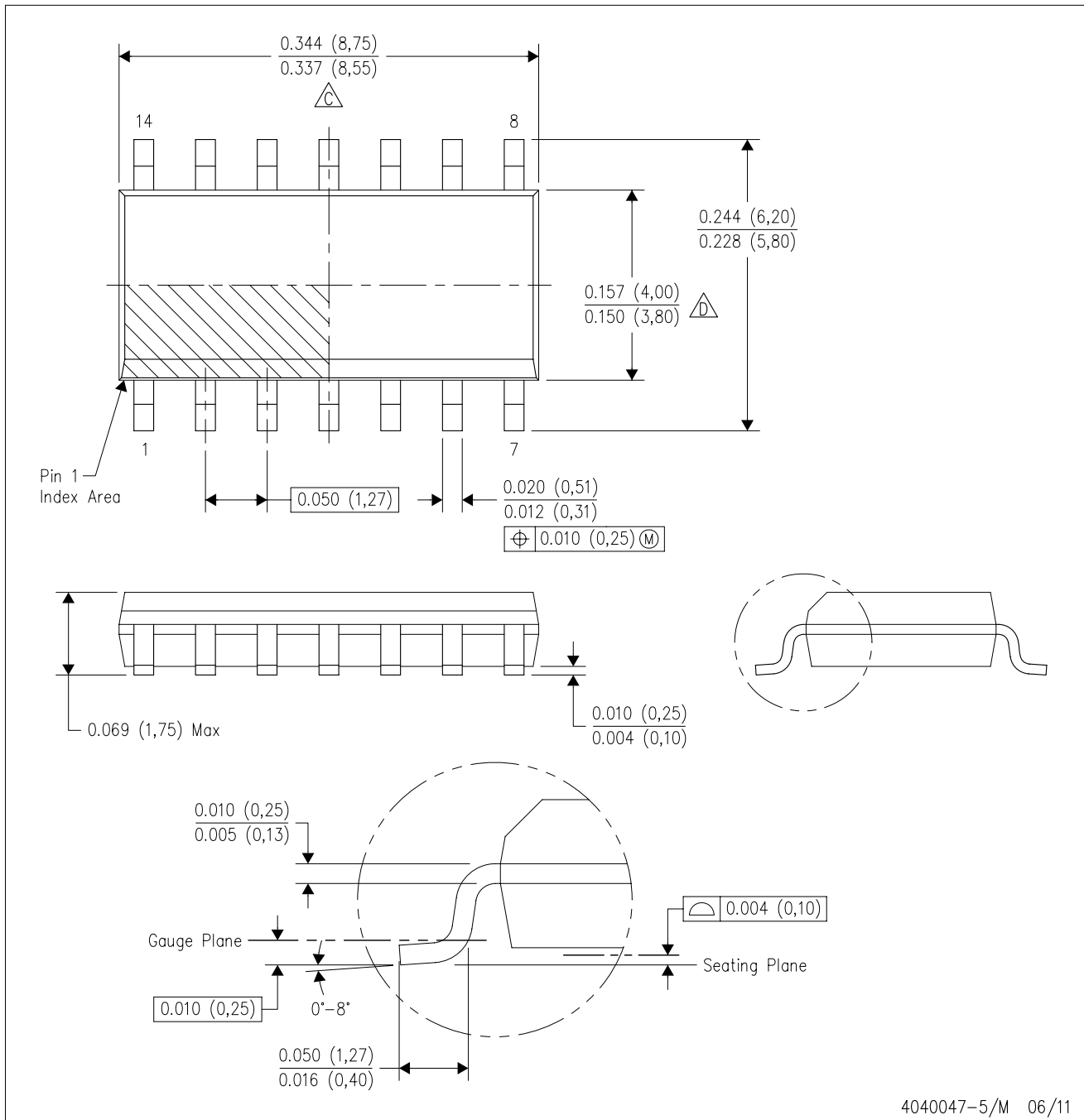

- NOTES:
- A. All linear dimensions are in inches (millimeters).
 - B. This drawing is subject to change without notice.
 - $\triangle C$ Body length does not include mold flash, protrusions, or gate burrs. Mold flash, protrusions, or gate burrs shall not exceed 0.006 (0,15) each side.
 - $\triangle D$ Body width does not include interlead flash. Interlead flash shall not exceed 0.017 (0,43) each side.
 - E. Reference JEDEC MS-012 variation AB.

D (R-PDSO-G14)

PLASTIC SMALL OUTLINE



4211283-3/E 08/12

- NOTES:
- A. All linear dimensions are in millimeters.
 - B. This drawing is subject to change without notice.
 - C. Publication IPC-7351 is recommended for alternate designs.
 - D. Laser cutting apertures with trapezoidal walls and also rounding corners will offer better paste release. Customers should contact their board assembly site for stencil design recommendations. Refer to IPC-7525 for other stencil recommendations.
 - E. Customers should contact their board fabrication site for solder mask tolerances between and around signal pads.

N (R-PDIP-T**)

PLASTIC DUAL-IN-LINE PACKAGE

16 PINS SHOWN



- NOTES:
- A. All linear dimensions are in inches (millimeters).
 - B. This drawing is subject to change without notice.
 - $\triangle C$ Falls within JEDEC MS-001, except 18 and 20 pin minimum body length (Dim A).
 - $\triangle D$ The 20 pin end lead shoulder width is a vendor option, either half or full width.

4040049/E 12/2002

IMPORTANT NOTICE AND DISCLAIMER

TI PROVIDES TECHNICAL AND RELIABILITY DATA (INCLUDING DATASHEETS), DESIGN RESOURCES (INCLUDING REFERENCE DESIGNS), APPLICATION OR OTHER DESIGN ADVICE, WEB TOOLS, SAFETY INFORMATION, AND OTHER RESOURCES "AS IS" AND WITH ALL FAULTS, AND DISCLAIMS ALL WARRANTIES, EXPRESS AND IMPLIED, INCLUDING WITHOUT LIMITATION ANY IMPLIED WARRANTIES OF MERCHANTABILITY, FITNESS FOR A PARTICULAR PURPOSE OR NON-INFRINGEMENT OF THIRD PARTY INTELLECTUAL PROPERTY RIGHTS.

These resources are intended for skilled developers designing with TI products. You are solely responsible for (1) selecting the appropriate TI products for your application, (2) designing, validating and testing your application, and (3) ensuring your application meets applicable standards, and any other safety, security, or other requirements. These resources are subject to change without notice. TI grants you permission to use these resources only for development of an application that uses the TI products described in the resource. Other reproduction and display of these resources is prohibited. No license is granted to any other TI intellectual property right or to any third party intellectual property right. TI disclaims responsibility for, and you will fully indemnify TI and its representatives against, any claims, damages, costs, losses, and liabilities arising out of your use of these resources.

TI's products are provided subject to TI's Terms of Sale (www.ti.com/legal/termsofsale.html) or other applicable terms available either on ti.com or provided in conjunction with such TI products. TI's provision of these resources does not expand or otherwise alter TI's applicable warranties or warranty disclaimers for TI products.

Mailing Address: Texas Instruments, Post Office Box 655303, Dallas, Texas 75265
Copyright © 2020, Texas Instruments Incorporated