

DATA SHEET

050/052 PED-PW

Aluminum electrolytic capacitors
Power Eurodin Printed Wiring

Product specification
Supersedes data of 18th January 2000
File under BCcomponents, BC01

2001 Nov 14

Aluminum electrolytic capacitors Power Eurodin Printed Wiring

050/052 PED-PW

FEATURES

- Polarized aluminum electrolytic capacitors, non-solid electrolyte
- Large types, cylindrical aluminum case, insulated with a blue sleeve
- Provided with keyed polarity
- 050 series also available in solder-lug (SL) versions
- Very long useful life: 15000 hours at 85 °C
- Low ESR, high ripple current capability
- High resistance to shock and vibration.

APPLICATIONS

- Computer, telecommunication and industrial systems
- Smoothing and filtering
- Standard and switched mode power supplies
- Energy storage in pulse systems.

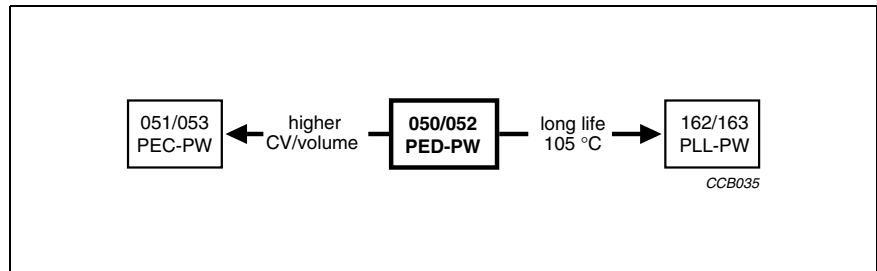
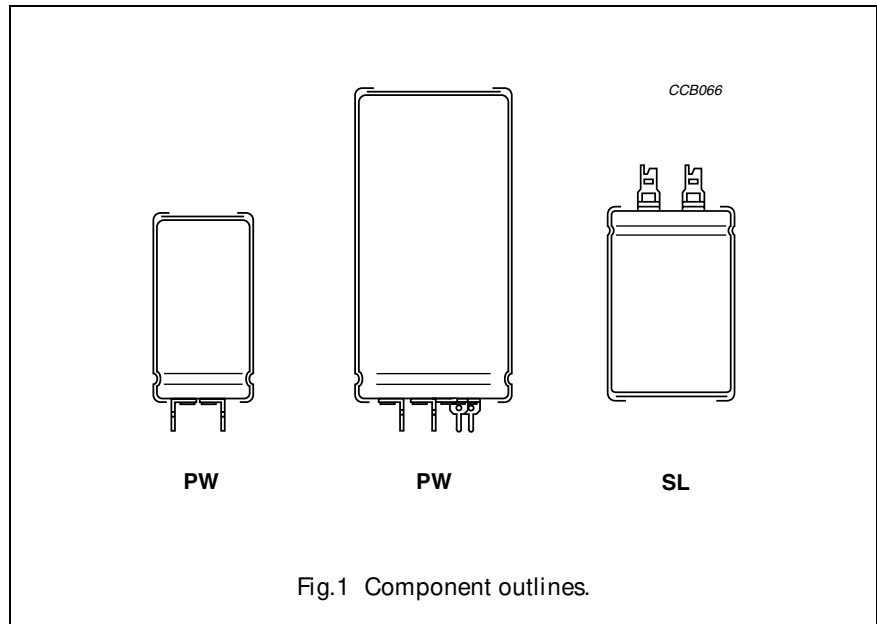

QUICK REFERENCE DATA

DESCRIPTION	VALUE	
	050	052
Case size ($\varnothing D_{nom} \times L_{nom}$ in mm)	25 × 30 to 40 × 100	
Rated capacitance range (E6 series), C_R	470 to 68000 μF	47 to 1000 μF
Tolerance on C_R	-10 to +30%	
Rated voltage range, U_R	10 to 100 V	250 to 400 V
Category temperature range	-40 to +85 °C	
Endurance test at 85 °C	5000 hours	
Useful life at 85 °C	15000 hours	
Useful life at 40 °C and $1.4 \times I_R$ applied	250000 hours	
Shelf life at 0 V, 85 °C	500 hours	
Based on sectional specification	IEC 60384-4/EN130300	
Climatic category IEC 60068	40/085/56	

Aluminum electrolytic capacitors

Power Eurodin Printed Wiring

050/052 PED-PW

Selection chart for C_R , U_R and relevant nominal case sizes ($\varnothing D \times L$ in mm) for 050 series

Preferred types in **bold**.

C_R (μF)	U_R (V)					
	10	16	25	40	63	100
470	–	–	–	–	–	25 × 30
680	–	–	–	–	–	25 × 40
1000	–	–	–	–	25 × 30	30 × 40
1500	–	–	–	25 × 30	25 × 40	35 × 40
2200	–	–	25 × 30	25 × 40	30 × 40	35 × 50
	–	–	–	–	–	40 × 40
3300	–	25 × 30	25 × 40	30 × 40	35 × 40	40 × 50
4700	25 × 30	25 × 40	30 × 40	35 × 40	35 × 50	40 × 70
	–	–	–	–	40 × 40	–
6800	25 × 40	30 × 40	35 × 40	35 × 50	40 × 50	40 × 100
	–	–	–	40 × 40	–	–
10000	30 × 40	35 × 40	35 × 50	40 × 50	40 × 70	–
	–	–	40 × 40	–	–	–
15000	35 × 40	35 × 50	40 × 50	40 × 70	40 × 100	–
	–	40 × 40	–	–	–	–
22000	35 × 50	40 × 50	40 × 70	40 × 100	–	–
	40 × 40	–	–	–	–	–
33000	40 × 50	40 × 70	40 × 100	–	–	–
47000	40 × 70	40 × 100	–	–	–	–
68000	40 × 100	–	–	–	–	–

Selection chart for C_R , U_R and relevant nominal case sizes ($\varnothing D \times L$ in mm) for 052 series

Preferred types in **bold**.

C_R (μF)	U_R (V)		
	250	385	400
47	–	25 × 30	25 × 30
68	–	25 × 40	25 × 40
100	25 × 30	30 × 40	30 × 40
150	25 × 40	35 × 40	35 × 40
220	30 × 40	35 × 50	35 × 50
	–	40 × 40	40 × 40
330	35 × 40	40 × 50	40 × 50
470	35 × 50	40 × 70	40 × 70
	40 × 40	–	–
680	40 × 50	–	40 × 100
1000	40 × 70	–	–

Aluminum electrolytic capacitors Power Eurodin Printed Wiring

050/052 PED-PW

MECHANICAL DATA AND PACKAGING QUANTITIES

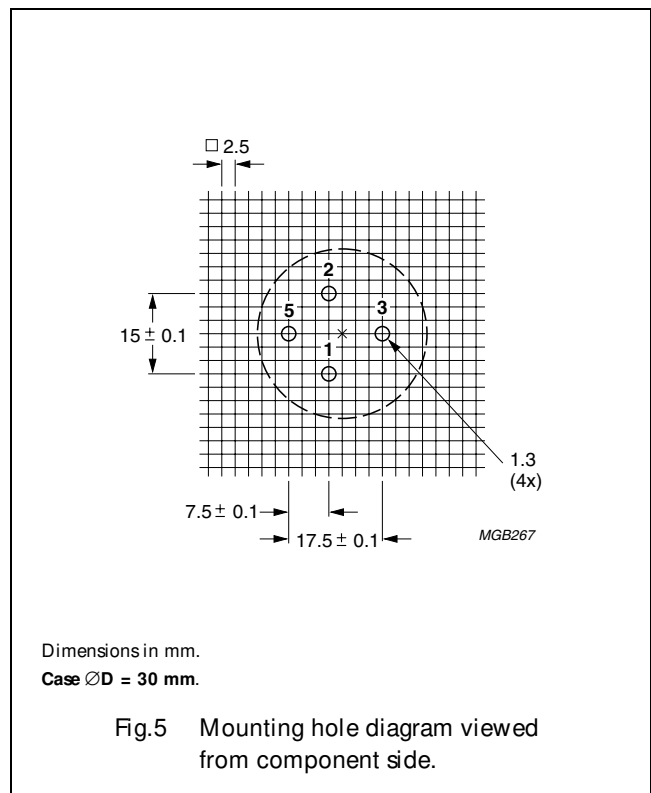
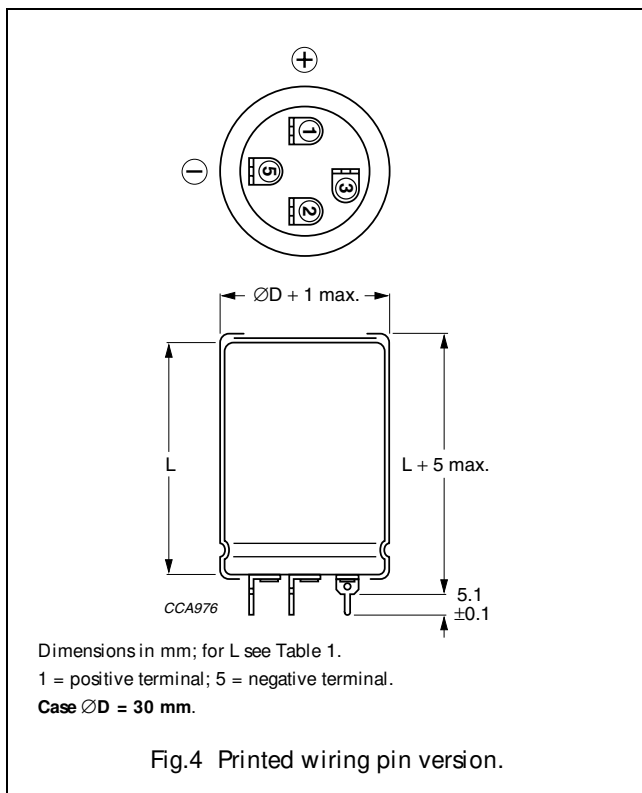
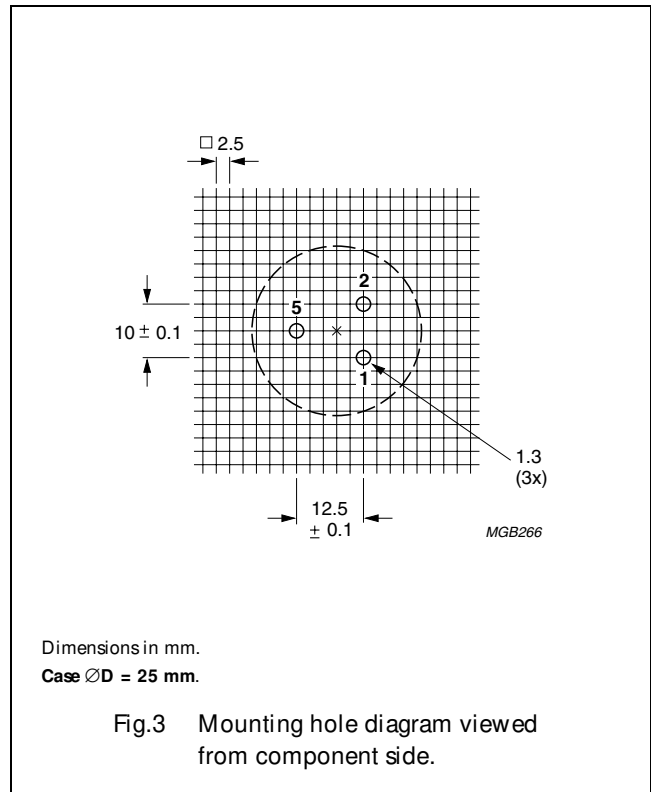
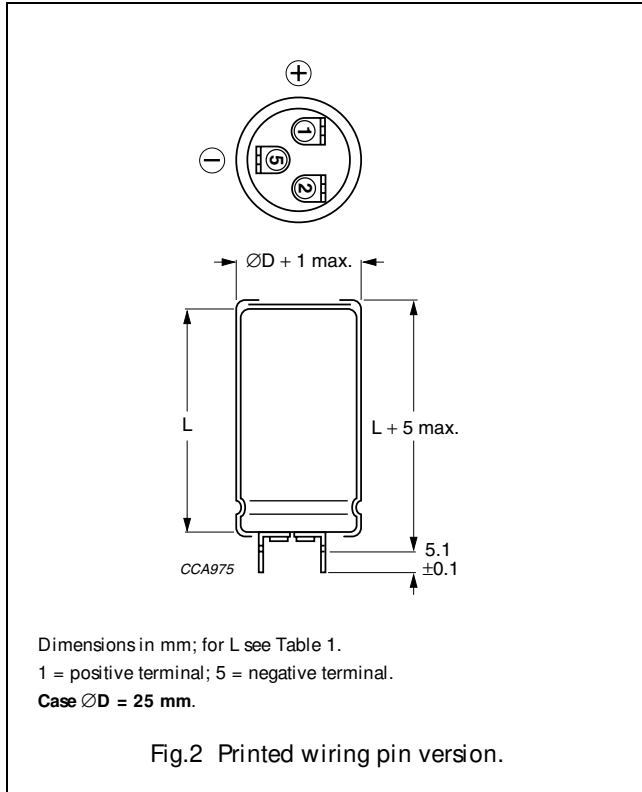

Aluminum electrolytic capacitors Power Eurodin Printed Wiring

050/052 PED-PW

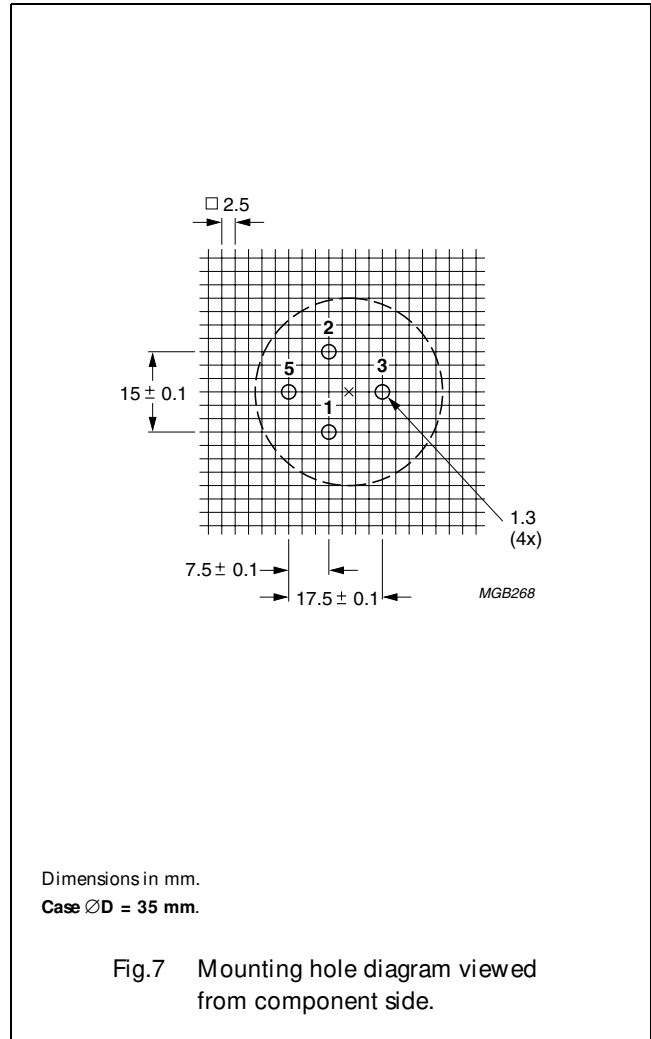
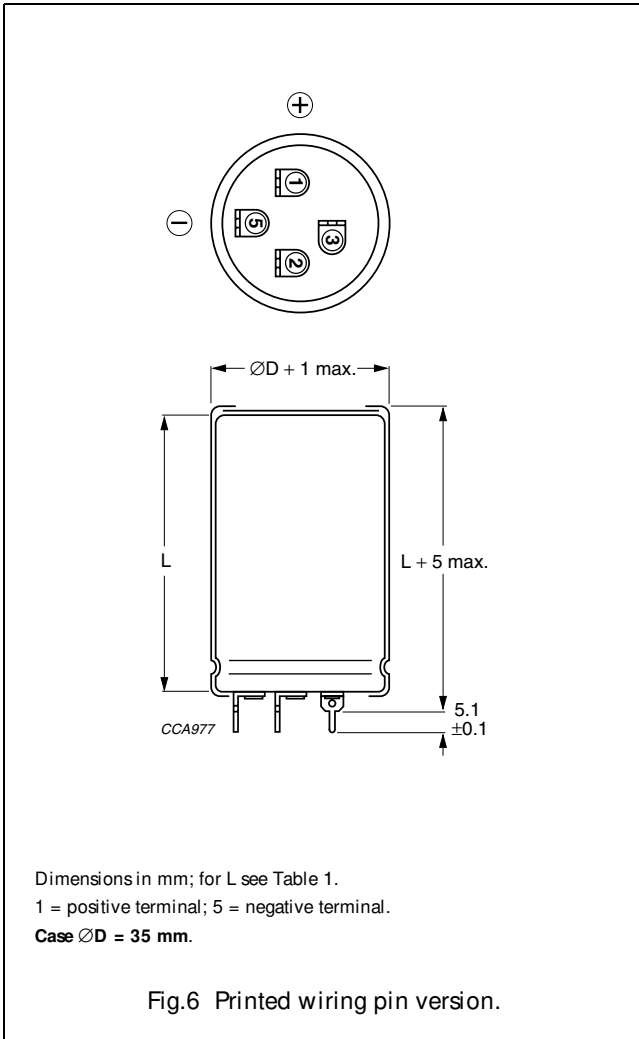
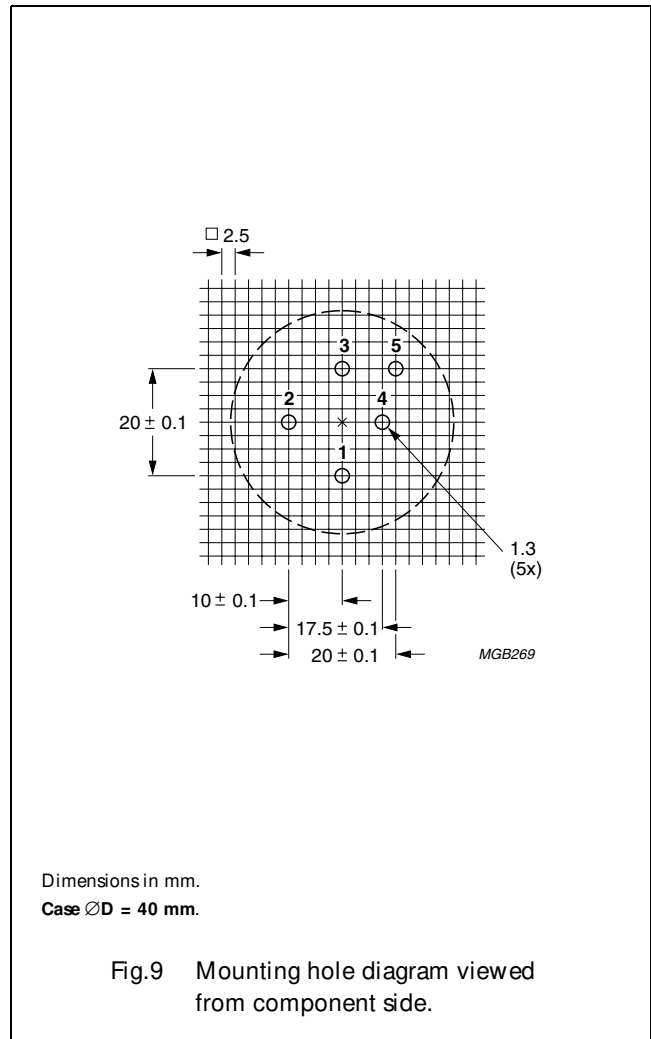
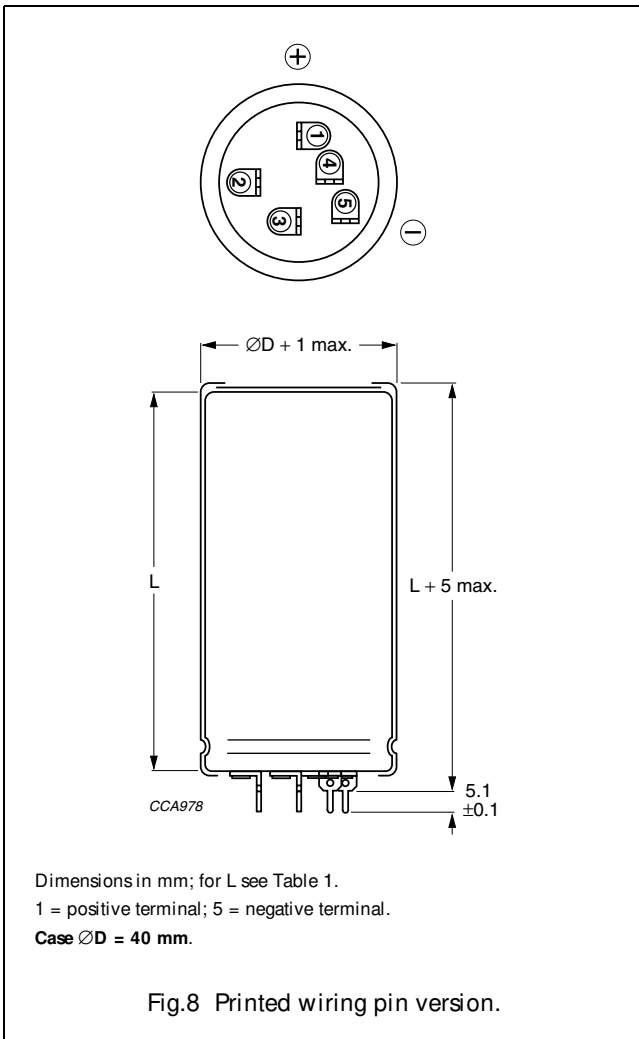

Table 1 PW versions; physical dimensions, mass and packaging information; see Figs 2, 4, 6 and 8

NOMINAL CASE SIZE ØD × L (mm)	ØD _{max} (mm)	L _{max} (mm)	MASS (g)	PACKAGING QUANTITIES (units per box)	CARD BOARD BOX DIMENSIONS l × w × h (mm)
25 × 30	26	35	≈24	100	290 × 280 × 50
25 × 40	26	45	≈28	100	290 × 280 × 60
30 × 40	31	45	≈38	100	340 × 330 × 60
35 × 40	36	45	≈51	50	390 × 198 × 60
35 × 50	36	55	≈66	50	390 × 198 × 70
40 × 40	41	45	≈78	50	440 × 223 × 60
40 × 50	41	55	≈82	50	440 × 223 × 70
40 × 70	41	75	≈110	50	440 × 223 × 90
40 × 100	41	105	≈176	50	440 × 223 × 120

Aluminum electrolytic capacitors
Power Eurodin Printed Wiring

050/052 PED-PW



Mounting

When a number of capacitors are connected in a bank, they must not be closer together than 15 mm, when no derating of ripple current and/or temperature is applied.

Pin numbers 2, 3 and 4 (if present) must be free from the electrical circuit.

Aluminum electrolytic capacitors
Power Eurodin Printed Wiring

050/052 PED-PW

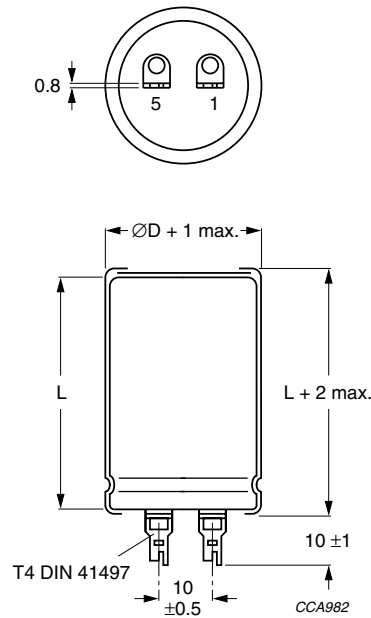

Dimensions in mm; for L see Table 2.
1 = positive terminal; 5 = negative terminal.
See this handbook, section "Mounting Accessories".

Fig.10 Solder-lug version (SL); only available in 050 series.

Table 2 SL versions (050 series only); physical dimensions, mass and packaging information; see Fig.10

NOMINAL CASE SIZE ØD × L (mm)	ØD _{max} (mm)	L _{max} (mm)	MASS (g)	PACKAGING QUANTITIES (units per box)	CARDBOARD BOX DIMENSIONS l × w × h (mm)
25 × 30	26	32	≈24	100	290 × 280 × 50
25 × 40	26	42	≈28	100	290 × 280 × 60
30 × 40	31	42	≈38	100	340 × 330 × 60
35 × 40	36	42	≈51	50	390 × 198 × 60
35 × 50	36	52	≈66	50	390 × 198 × 70
40 × 50	41	52	≈82	50	440 × 223 × 70
40 × 70	41	72	≈110	50	440 × 223 × 90
40 × 100	41	102	≈176	50	440 × 223 × 120

Aluminum electrolytic capacitors

Power Eurodin Printed Wiring

050/052 PED-PW

ELECTRICAL DATA AND ORDERING INFORMATION

Unless otherwise specified, all electrical values in Tables 3 and 4 apply at $T_{amb} = 20\text{ °C}$, $P = 86$ to 106 kPa , $RH = 45$ to 75% .

SYMBOL	DESCRIPTION
C_R	rated capacitance at 100 Hz
I_R	rated RMS ripple current at 100 Hz, 85 °C or at 20 kHz, 70 °C
I_{L1}	max. leakage current after 1 minute at U_R
I_{L5}	max. leakage current after 5 minutes at U_R
ESR	max. equivalent series resistance at 100 Hz
Z	max. impedance at 10 kHz

Ordering example

Electrolytic capacitor 050 series

10000 $\mu\text{F}/25\text{ V}$; $-10/+30\%$ Nominal case size: $\varnothing 35 \times 50\text{ mm}$;
PW version

Catalogue number: 2222 050 56103.

Table 3 Electrical data and ordering information for **050** series; preferred types in **bold**

U_R (V)	C_R 100 Hz (μF)	NOMINAL CASE SIZE $\varnothing D \times L$ (mm)	I_R 100 Hz 85 °C (A)	I_R 20 kHz 70 °C (A)	I_{L1} 1 min (mA)	I_{L5} 5 min (mA)	ESR 100 Hz (m Ω)	Z 10 kHz (m Ω)	CATALOGUE NUMBER (note 1) 2222
10	4700	25 × 30	2.4	4.6	0.28	0.10	74	50	050 54472
	6800	25 × 40	3.2	6.1	0.41	0.14	51	37	050 54682
	10000	30 × 40	3.8	7.2	0.60	0.20	39	29	050 54103
	15000	35 × 40	4.1	7.8	0.90	0.30	35	26	050 54153
	22000	35 × 50	5.0	9.5	1.32	0.44	27	21	050 54223
	22000	40 × 40	4.2	8.0	1.32	0.44	36	27	050 44223
	33000	40 × 50	5.0	9.5	1.98	0.66	29	22	050 54333
	47000	40 × 70	6.8	12.9	2.82	0.94	20	17	050 54473
68000	40 × 100	9.2	17.5	4.08	1.36	15	14	050 54683	
16	3300	25 × 30	2.4	4.6	0.32	0.11	75	50	050 55332
	4700	25 × 40	3.1	5.9	0.45	0.15	52	37	050 55472
	6800	30 × 40	3.7	7.0	0.65	0.22	40	30	050 55682
	10000	35 × 40	4.1	7.8	0.96	0.32	36	27	050 55103
	15000	35 × 50	5.0	9.5	1.44	0.48	28	21	050 55153
	15000	40 × 40	4.2	8.0	1.44	0.48	36	27	050 45153
	22000	40 × 50	5.0	9.5	2.12	0.71	29	22	050 55223
	33000	40 × 70	6.7	12.7	3.17	1.06	20	17	050 55333
47000	40 × 100	9.1	17.3	4.51	1.51	15	14	050 55473	
25	2200	25 × 30	2.3	4.4	0.33	0.11	78	52	050 56222
	3300	25 × 40	3.1	5.9	0.49	0.17	53	38	050 56332
	4700	30 × 40	3.7	7.0	0.70	0.24	42	31	050 56472
	6800	35 × 40	4.1	7.8	1.02	0.34	37	28	050 56682
	10000	35 × 50	5.0	9.5	1.50	0.50	28	21	050 56103
	10000	40 × 40	4.2	8.0	1.50	0.50	36	27	050 46103
	15000	40 × 50	5.0	9.5	2.25	0.75	29	22	050 56153
	22000	40 × 70	6.8	12.9	3.30	1.10	20	17	050 56223
33000	40 × 100	9.2	17.5	4.95	1.65	15	14	050 56333	

Aluminum electrolytic capacitors

Power Eurodin Printed Wiring

050/052 PED-PW

U_R (V)	C_R 100 Hz (μ F)	NOMINAL CASE SIZE $\varnothing D \times L$ (mm)	I_R 100 Hz 85 °C (A)	I_R 20 kHz 70 °C (A)	I_{L1} 1 min (mA)	I_{L5} 5 min (mA)	ESR 100 Hz (m Ω)	Z 10 kHz (m Ω)	CATALOGUE NUMBER (note 1) 2222
40	1500	25 × 30	2.0	3.8	0.36	0.12	112	68	050 57152
	2200	25 × 40	2.7	5.1	0.53	0.18	76	51	050 57222
	3300	30 × 40	3.3	6.3	0.79	0.27	57	41	050 57332
	4700	35 × 40	3.8	7.2	1.13	0.38	48	35	050 57472
	6800	35 × 50	4.7	8.9	1.64	0.55	36	27	050 57682
	6800	40 × 40	4.1	7.8	1.64	0.55	45	33	050 47682
	10000	40 × 50	4.9	9.3	2.40	0.80	35	27	050 57103
	15000	40 × 70	6.6	12.5	3.60	1.20	25	20	050 57153
	22000	40 × 100	9.0	17.1	5.28	1.76	18	16	050 57223
63	1000	25 × 30	1.8	3.4	0.38	0.13	122	74	050 58102
	1500	25 × 40	2.5	4.7	0.57	0.19	83	54	050 58152
	2200	30 × 40	3.1	5.9	0.83	0.28	57	41	050 58222
	3300	35 × 40	3.6	6.8	1.25	0.42	48	35	050 58332
	4700	35 × 50	4.4	8.3	1.78	0.60	36	27	050 58472
	4700	40 × 40	3.8	7.2	1.78	0.60	45	33	050 48472
	6800	40 × 50	4.7	8.9	2.57	0.86	35	27	050 58682
	10000	40 × 70	6.2	11.8	3.78	1.26	25	20	050 58103
	15000	40 × 100	8.5	16.1	5.67	1.89	18	16	050 58153
100	470	25 × 30	1.4	2.7	0.28	0.10	247	172	050 59471
	680	25 × 40	1.9	3.6	0.41	0.14	170	116	050 59681
	1000	30 × 40	2.5	4.7	0.60	0.20	123	88	050 59102
	1500	35 × 40	3.1	5.8	0.90	0.30	94	71	050 59152
	2200	35 × 50	3.9	7.4	1.32	0.44	69	55	050 59222
	2200	40 × 40	3.6	6.8	1.32	0.44	81	65	050 49222
	3300	40 × 50	4.6	8.7	1.98	0.66	59	48	050 59332
	4700	40 × 70	6.2	11.7	2.82	0.94	42	36	050 59472
	6800	40 × 100	8.2	15.5	4.08	1.36	32	28	050 59682

Note

- Catalogue number applies to the PW versions; for SL versions (not preferred) available in 050 series only (case size $\varnothing 40 \times 40$ mm not available) replace the 8th digit by '1': SL versions: 2222 050 1....

Aluminum electrolytic capacitors

Power Eurodin Printed Wiring

050/052 PED-PW

Table 4 Electrical data and ordering information for **052** series; preferred types in **bold**

U_R (V)	C_R 100 Hz (μ F)	NOMINAL CASE SIZE $\varnothing D \times L$ (mm)	I_R 100 Hz 85 °C (A)	I_R 20 kHz 70 °C (A)	I_{L1} 1 min (mA)	I_{L5} 5 min (mA)	ESR 100 Hz (m Ω)	Z 10 kHz (m Ω)	CATALOGUE NUMBER 2222
250	100	25 × 30	0.6	1.15	0.15	0.05	1800	1300	052 53101
	150	25 × 40	0.8	1.5	0.23	0.08	1100	850	052 53151
	220	30 × 40	1.0	1.9	0.33	0.11	750	550	052 53221
	330	35 × 40	1.4	2.65	0.49	0.17	500	400	052 53331
	470	35 × 50	1.8	3.4	0.70	0.24	360	290	052 53471
	470	40 × 40	1.8	3.4	0.70	0.24	420	350	052 43471
	680	40 × 50	2.3	4.4	1.02	0.34	250	190	052 53681
	1000	40 × 70	3.0	5.7	1.50	0.50	170	140	052 53102
385	47	25 × 30	0.5	0.94	0.11	0.04	2370	1550	052 58479
	68	25 × 40	0.67	1.27	0.16	0.06	1640	1100	052 58689
	100	30 × 40	0.84	1.59	0.23	0.08	1275	950	052 58101
	150	35 × 40	1.13	2.14	0.34	0.11	850	635	052 58151
	220	35 × 50	1.48	2.8	0.50	0.17	580	430	052 58221
	220	40 × 40	1.48	2.8	0.50	0.17	580	430	052 48221
	330	40 × 50	1.97	3.73	0.75	0.25	385	300	052 58331
	470	40 × 70	2.7	5.11	1.06	0.36	270	215	052 58471
400	47	25 × 30	0.47	0.89	0.11	0.04	2700	2125	052 56479
	68	25 × 40	0.63	1.29	0.16	0.06	1875	1470	052 56689
	100	30 × 40	0.84	1.59	0.24	0.08	1275	1000	052 56101
	150	35 × 40	1.13	2.14	0.36	0.12	850	665	052 56151
	220	35 × 50	1.41	2.67	0.52	0.17	650	450	052 56221
	220	40 × 40	1.41	2.67	0.52	0.17	650	450	052 46221
	330	40 × 50	1.86	3.52	0.79	0.26	435	315	052 56331
	470	40 × 70	2.54	4.81	1.12	0.37	305	225	052 56471
680	40 × 100	3.56	6.75	1.63	0.54	210	155	052 56681	

Aluminum electrolytic capacitors Power Eurodin Printed Wiring

050/052 PED-PW

Additional electrical data

PARAMETER	CONDITIONS	VALUE
Voltage		
Surge voltage	≤250 V versions	$U_s = 1.15 \times U_R$
	≥385 V versions	$U_s = 1.1 \times U_R$
Reverse voltage		$U_{rev} \leq 1 \text{ V}$
Current		
Leakage current	after 1 minute at U_R	$I_{L1} \leq 0.006C_R \times U_R + 4 \mu\text{A}$
	after 5 minutes at U_R	$I_{L5} \leq 0.002C_R \times U_R + 4 \mu\text{A}$
Inductance		
Equivalent series inductance (ESL)	case $\varnothing D = 25 \text{ mm}$	max. 25 nH
	case $\varnothing D = 30 \text{ and } 35 \text{ mm}$	max. 30 nH
	case $\varnothing D = 40 \text{ mm}$	max. 35 nH

Capacitance (C)

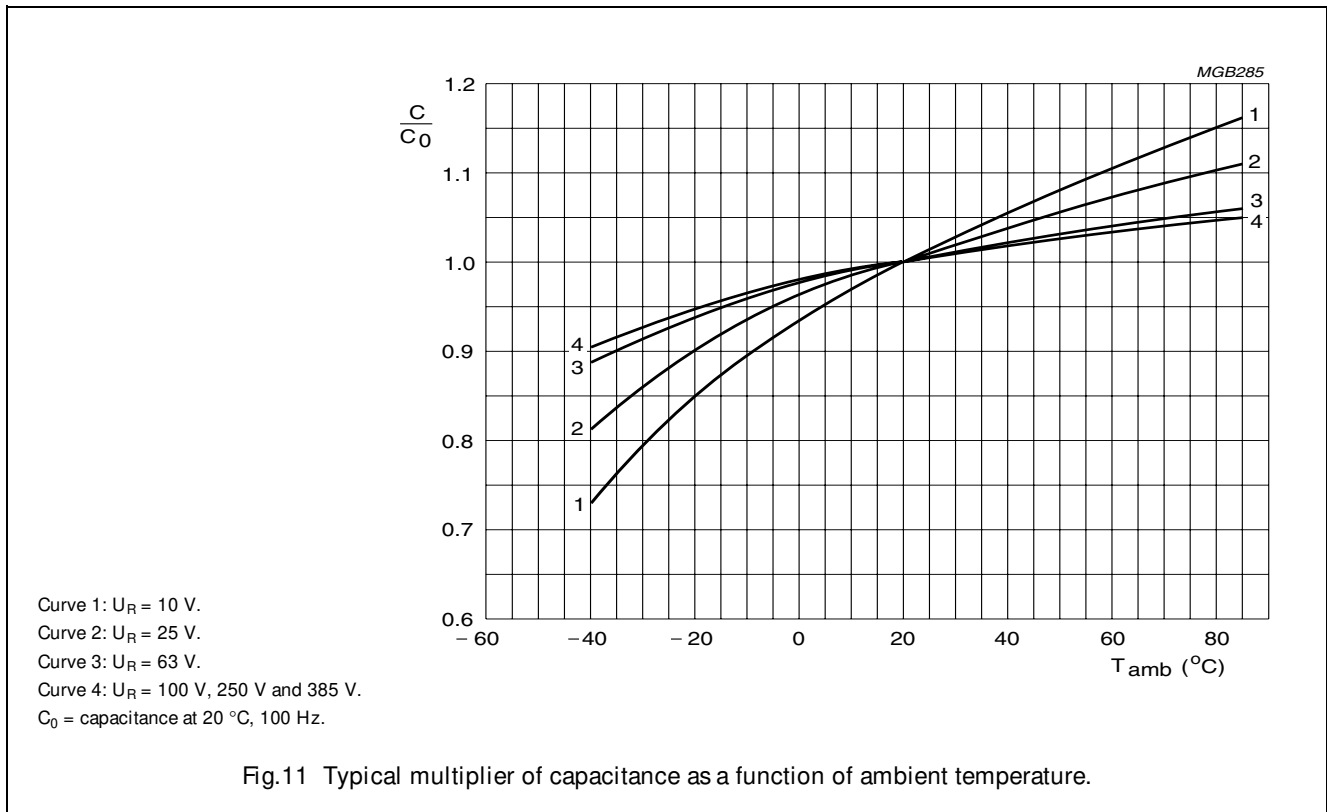

Aluminum electrolytic capacitors Power Eurodin Printed Wiring

050/052 PED-PW

Equivalent series resistance (ESR)

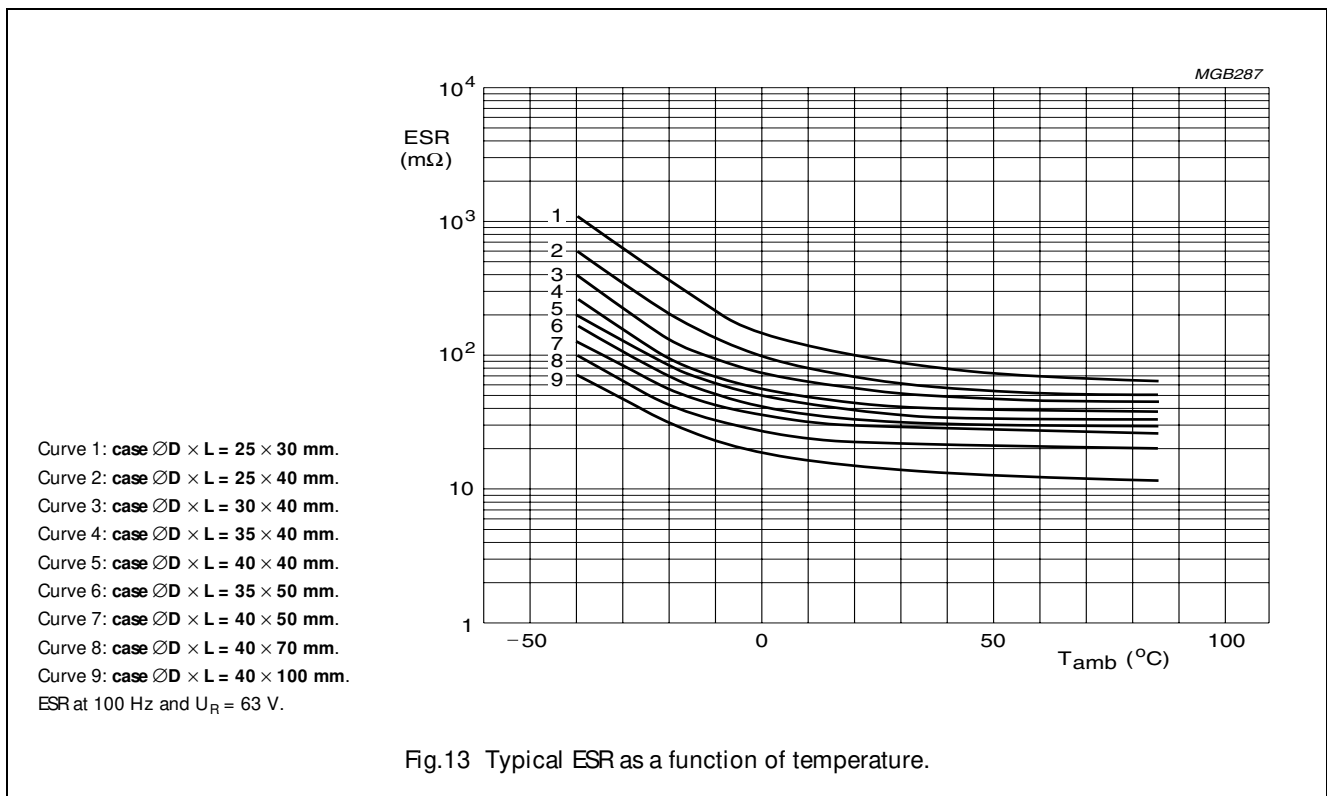
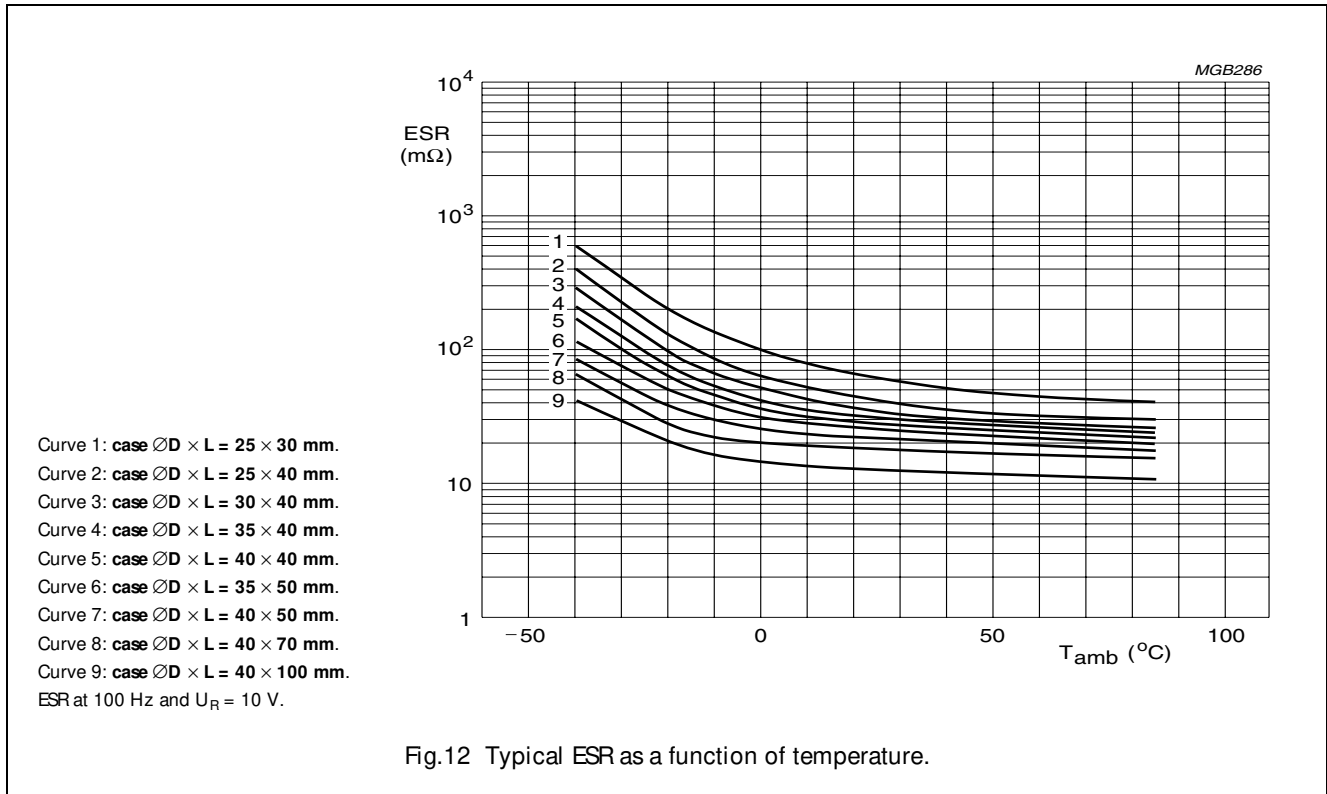

Aluminum electrolytic capacitors
Power Eurodin Printed Wiring

050/052 PED-PW

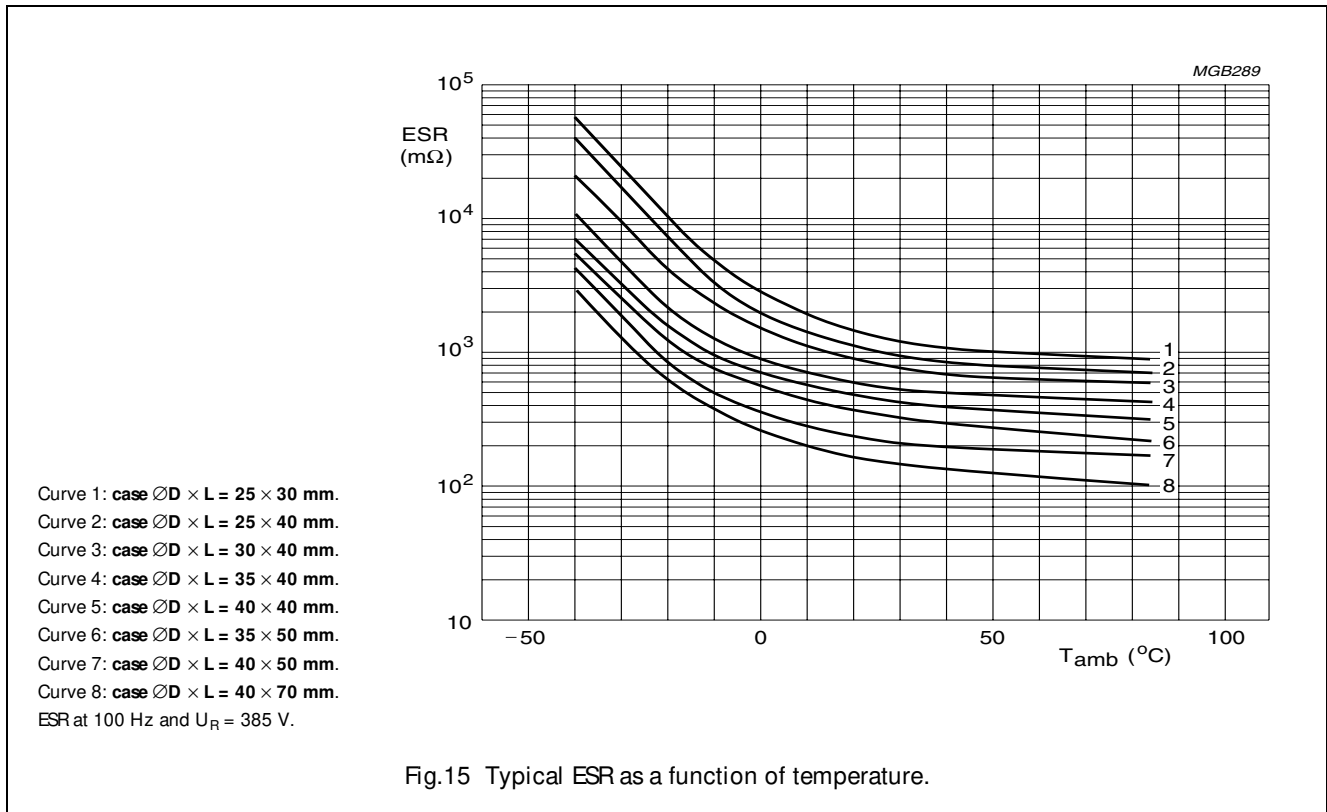
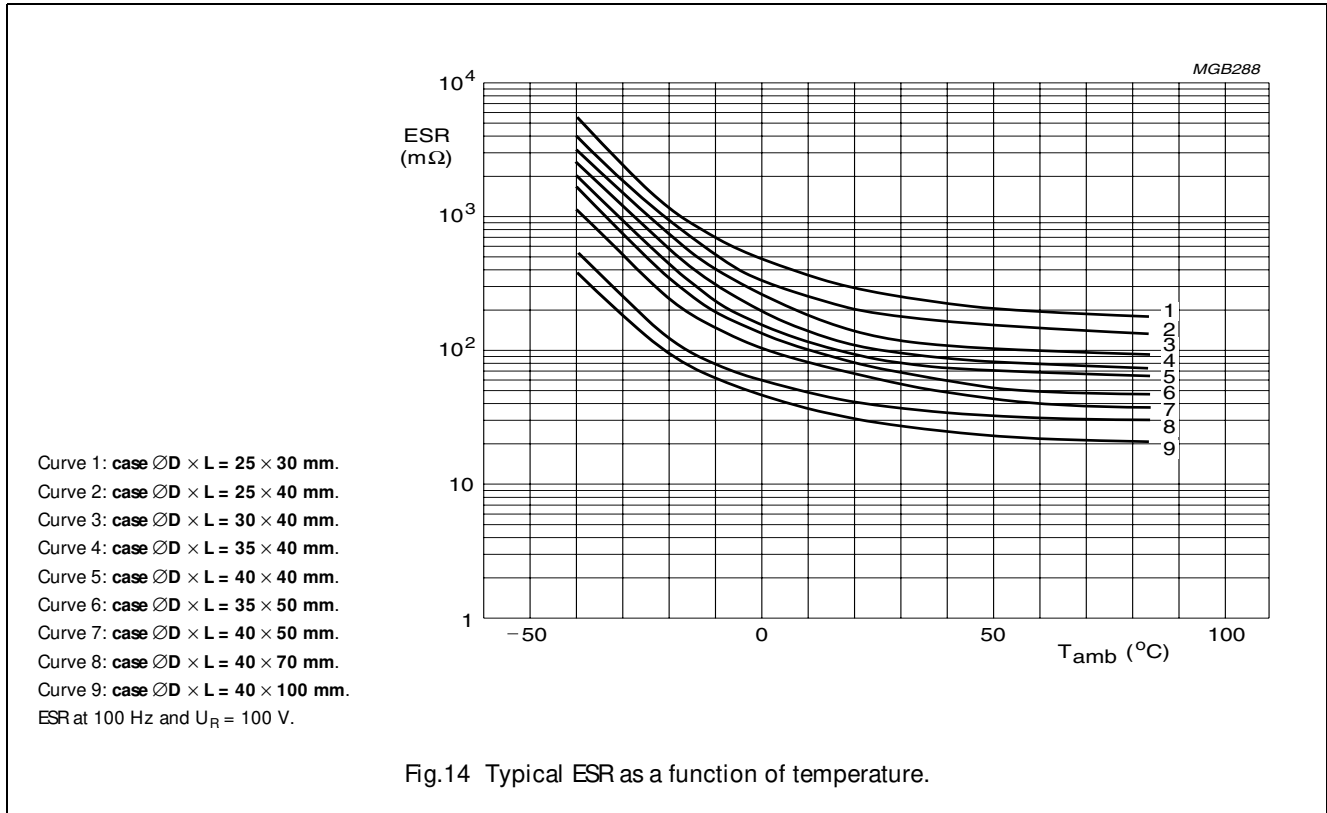

Aluminum electrolytic capacitors Power Eurodin Printed Wiring

050/052 PED-PW

Impedance (Z)

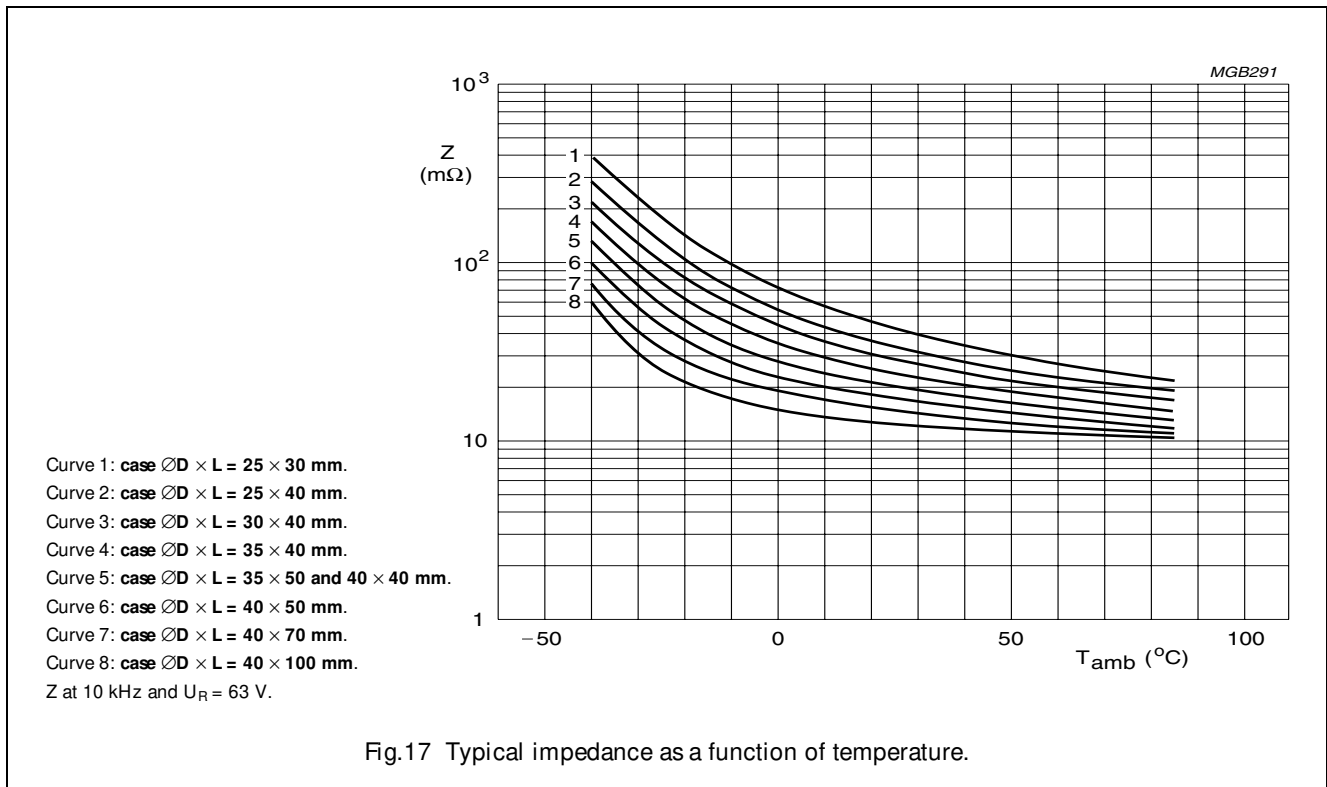
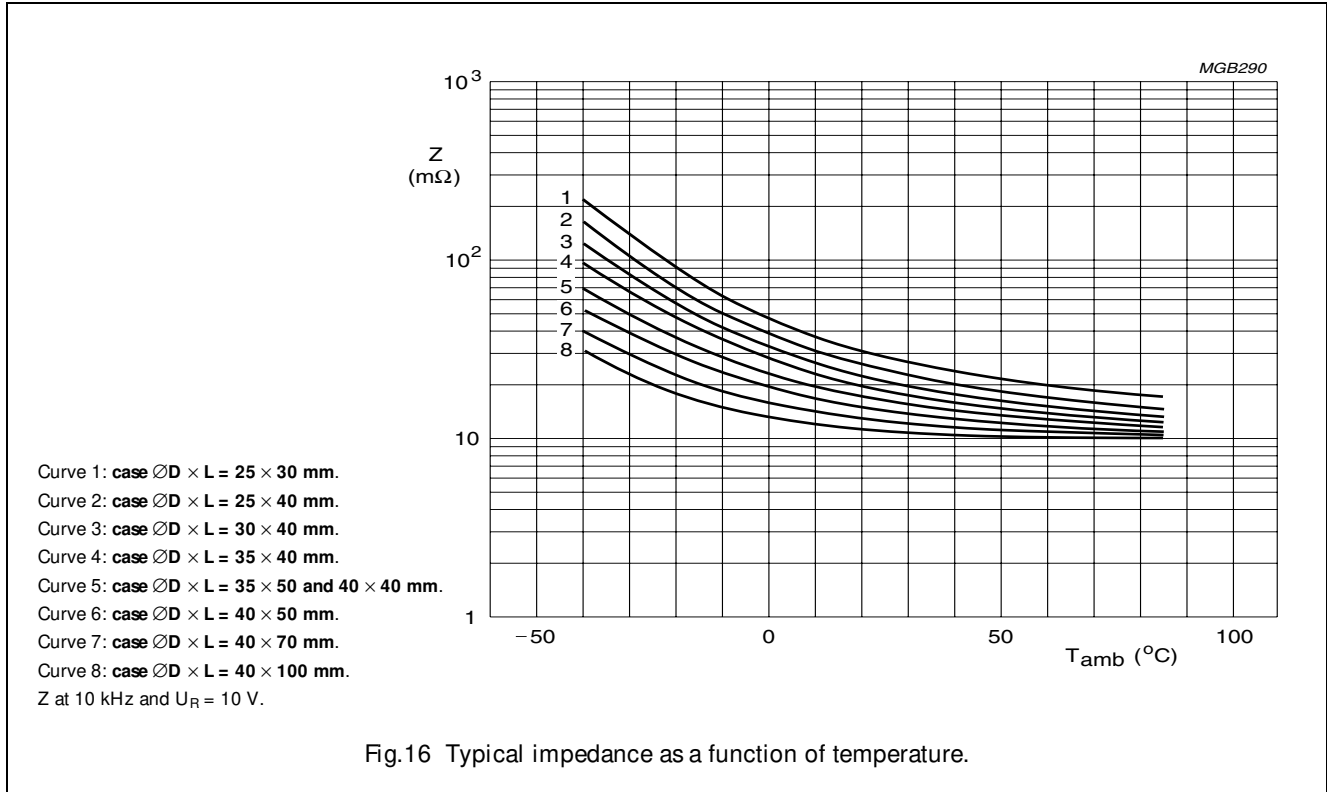

Aluminum electrolytic capacitors
Power Eurodin Printed Wiring

050/052 PED-PW

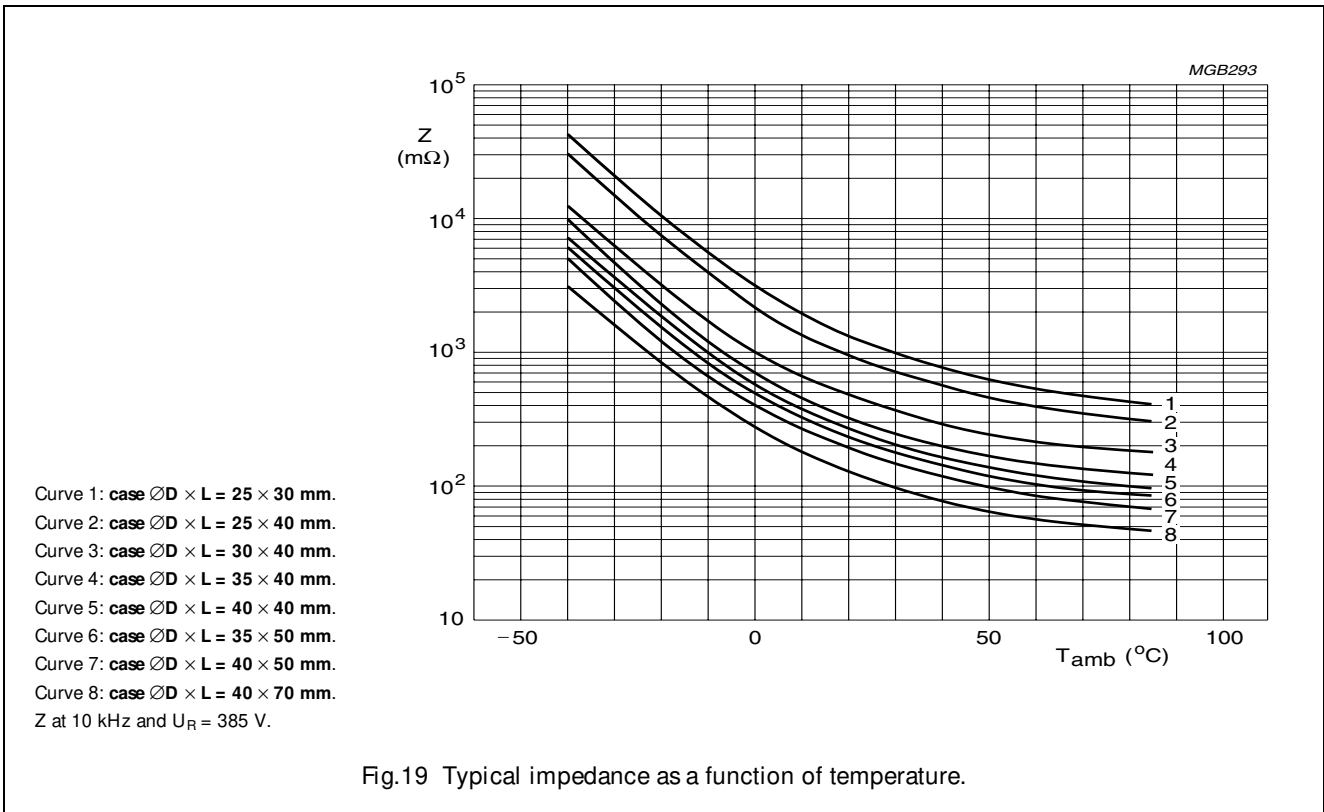
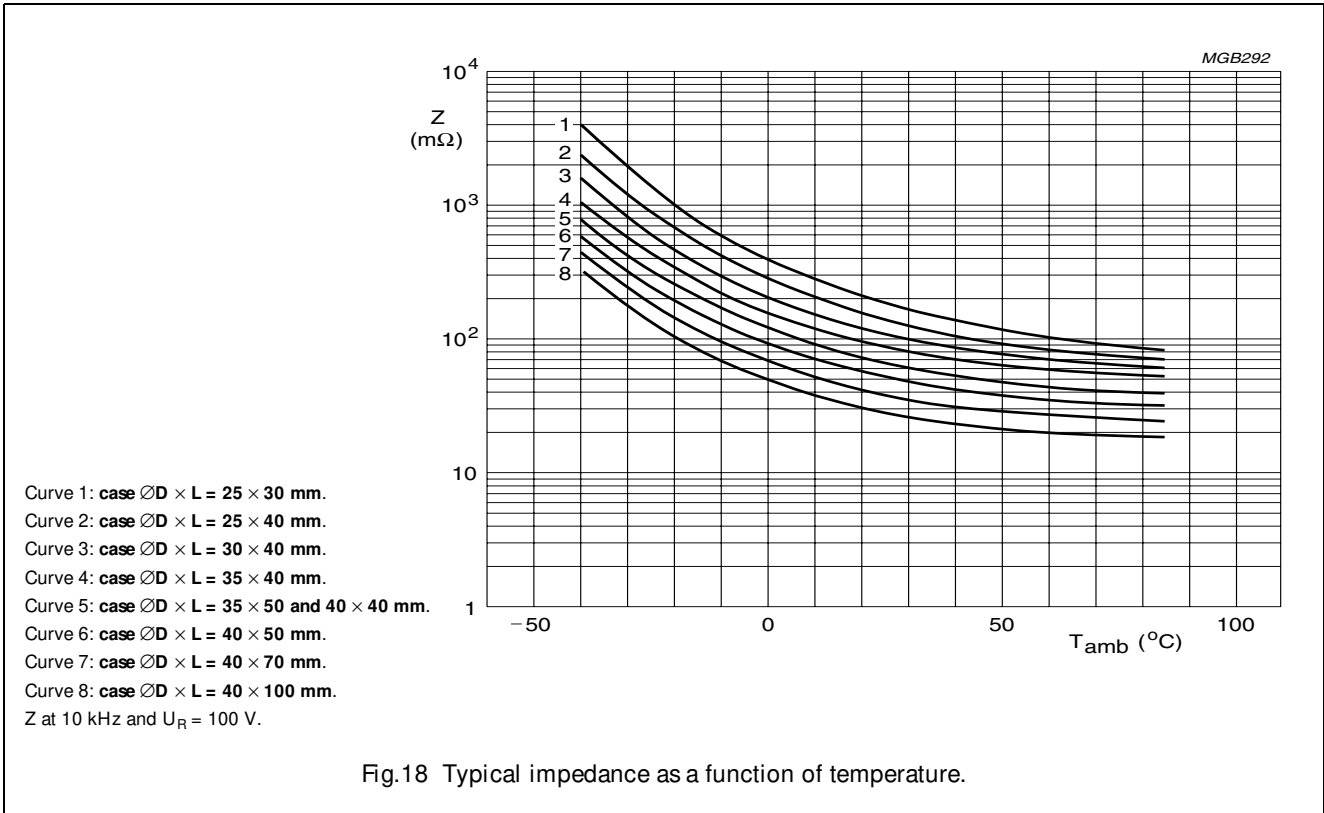

Aluminum electrolytic capacitors
Power Eurodin Printed Wiring

050/052 PED-PW

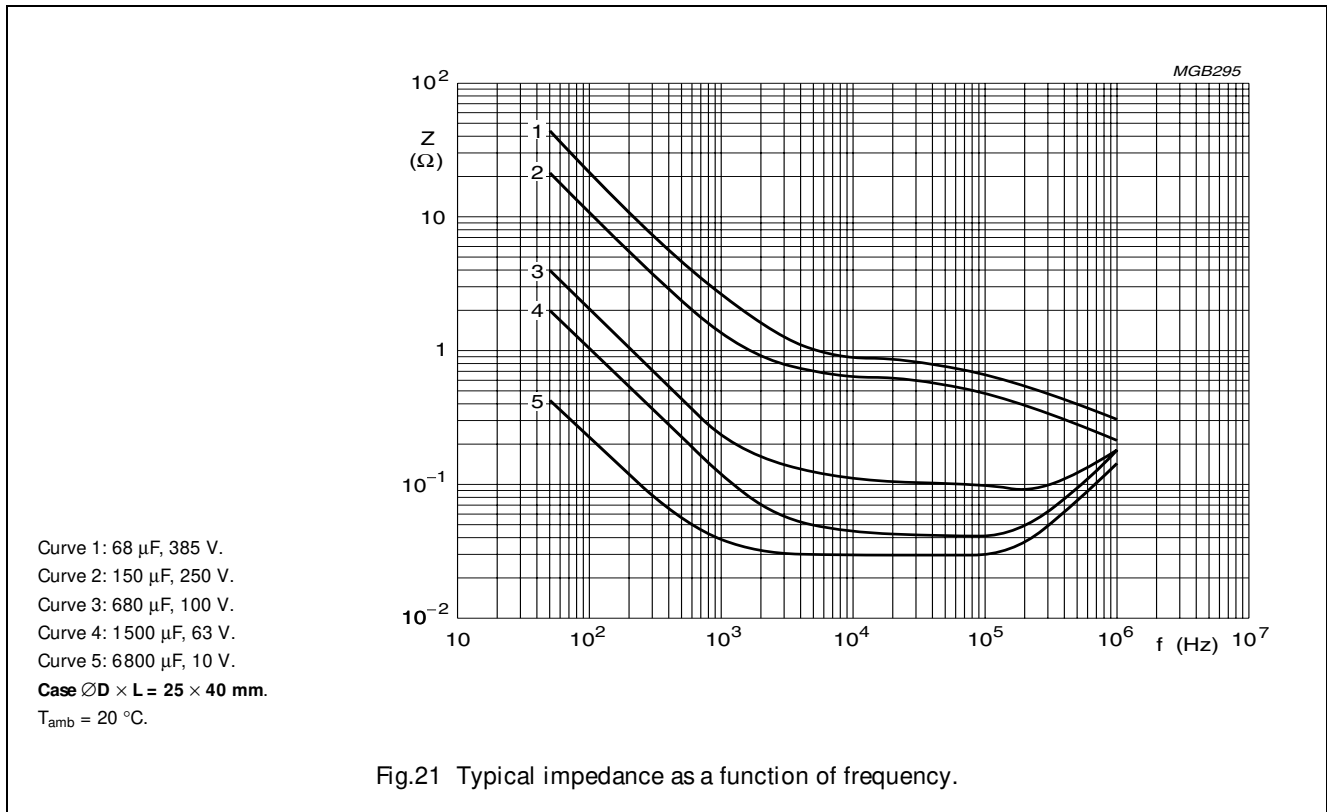
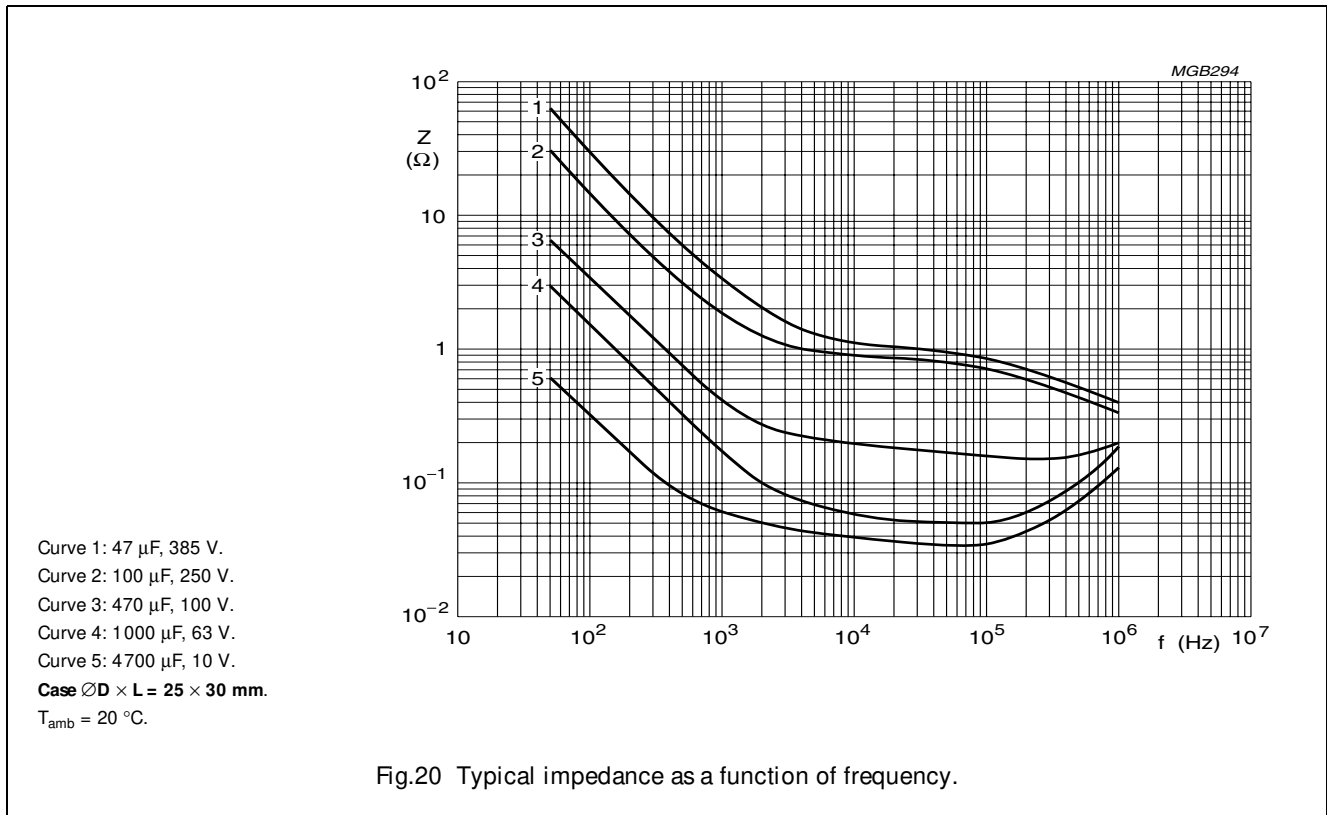

Aluminum electrolytic capacitors
Power Eurodin Printed Wiring

050/052 PED-PW

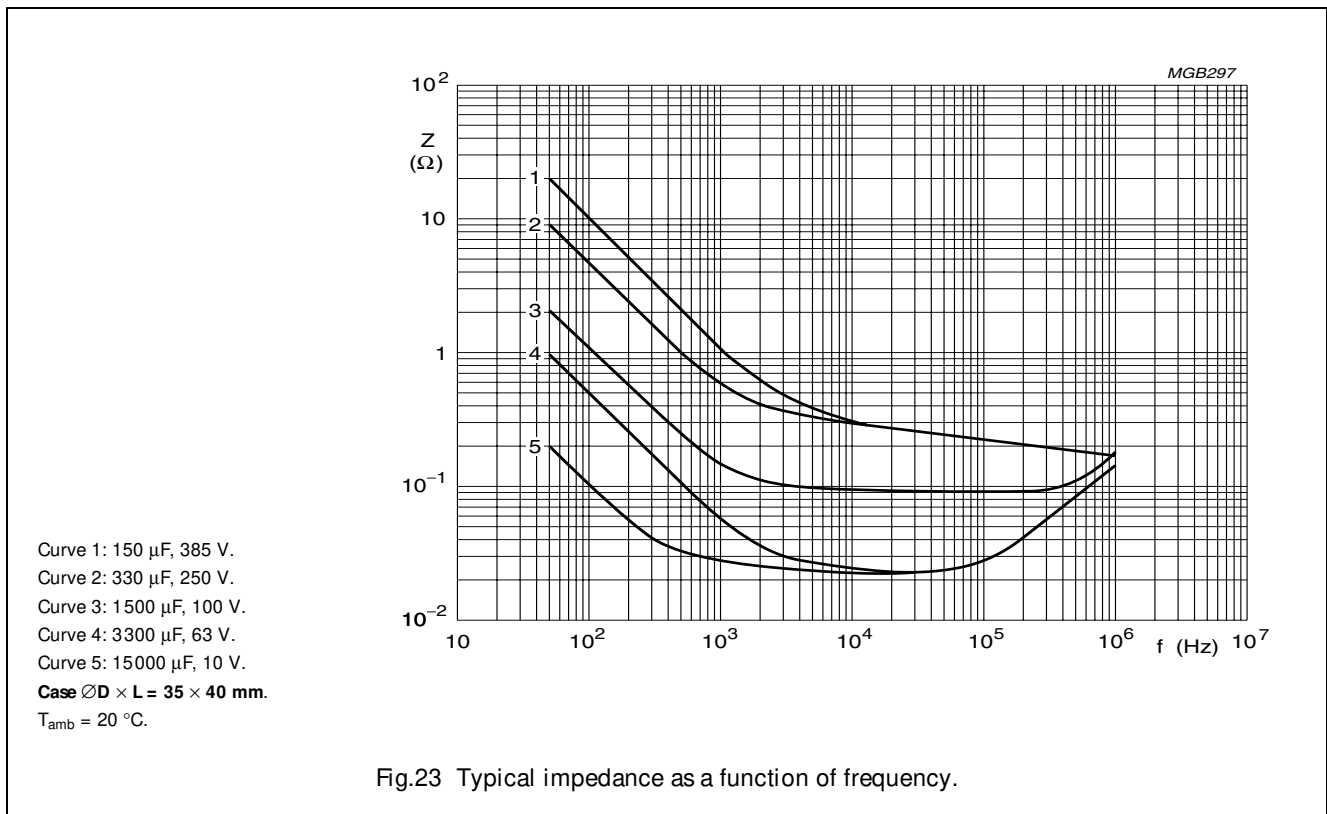
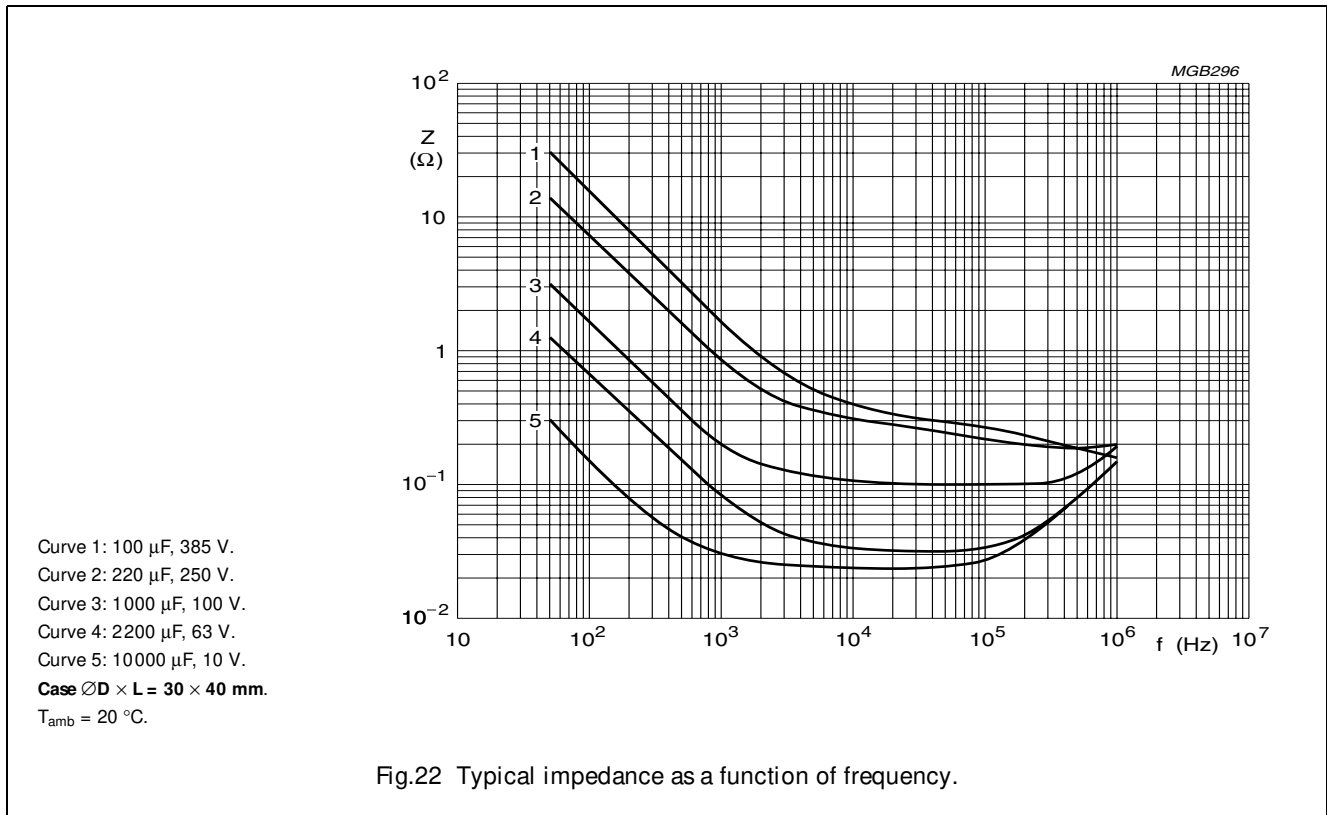

Aluminum electrolytic capacitors
Power Eurodin Printed Wiring

050/052 PED-PW

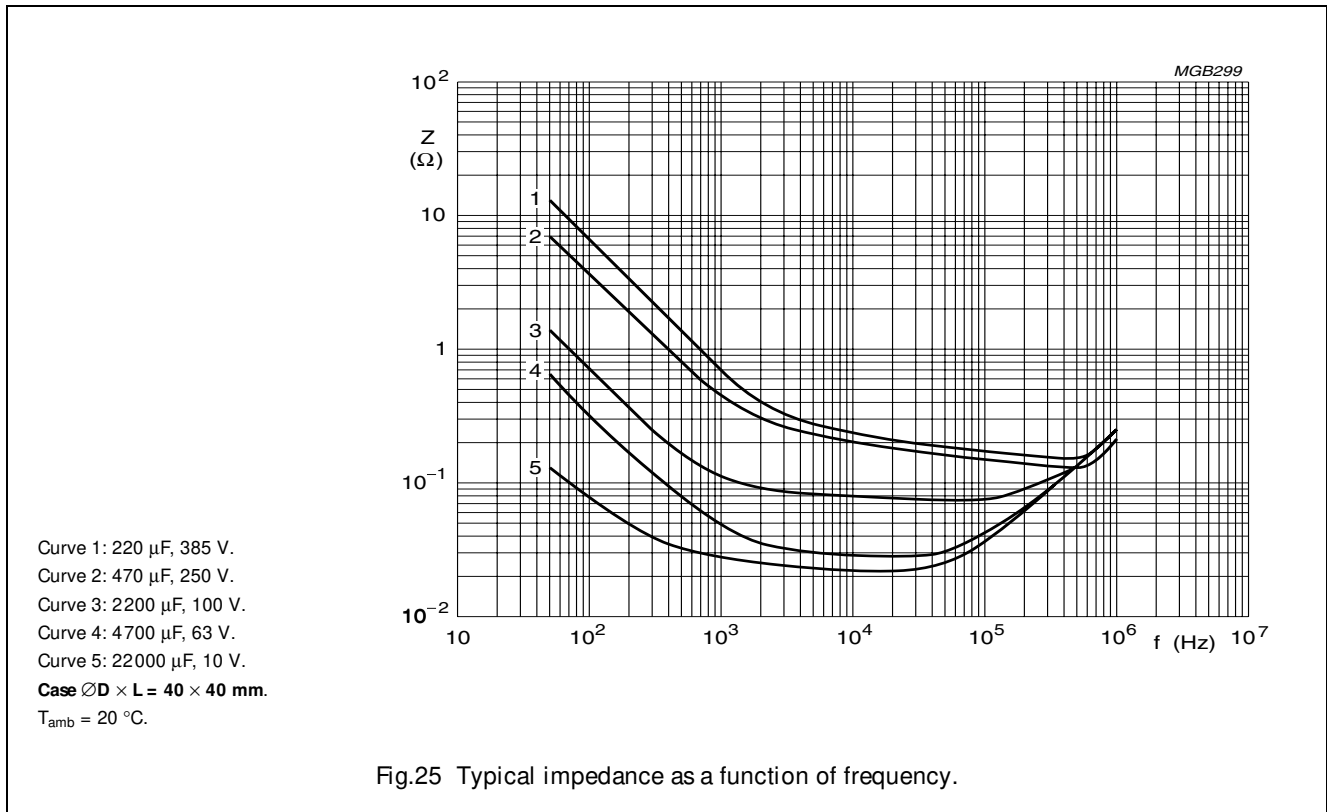
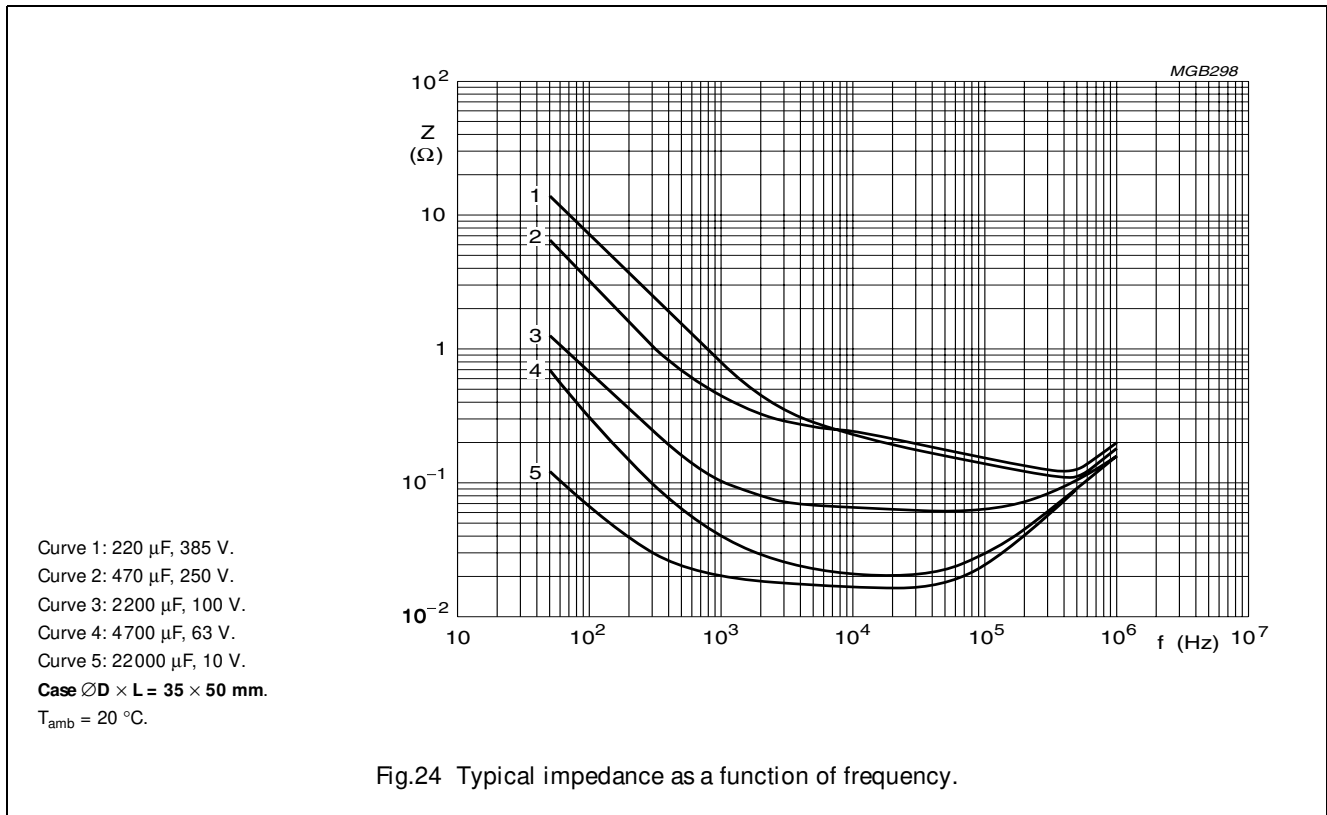

Aluminum electrolytic capacitors
Power Eurodin Printed Wiring

050/052 PED-PW

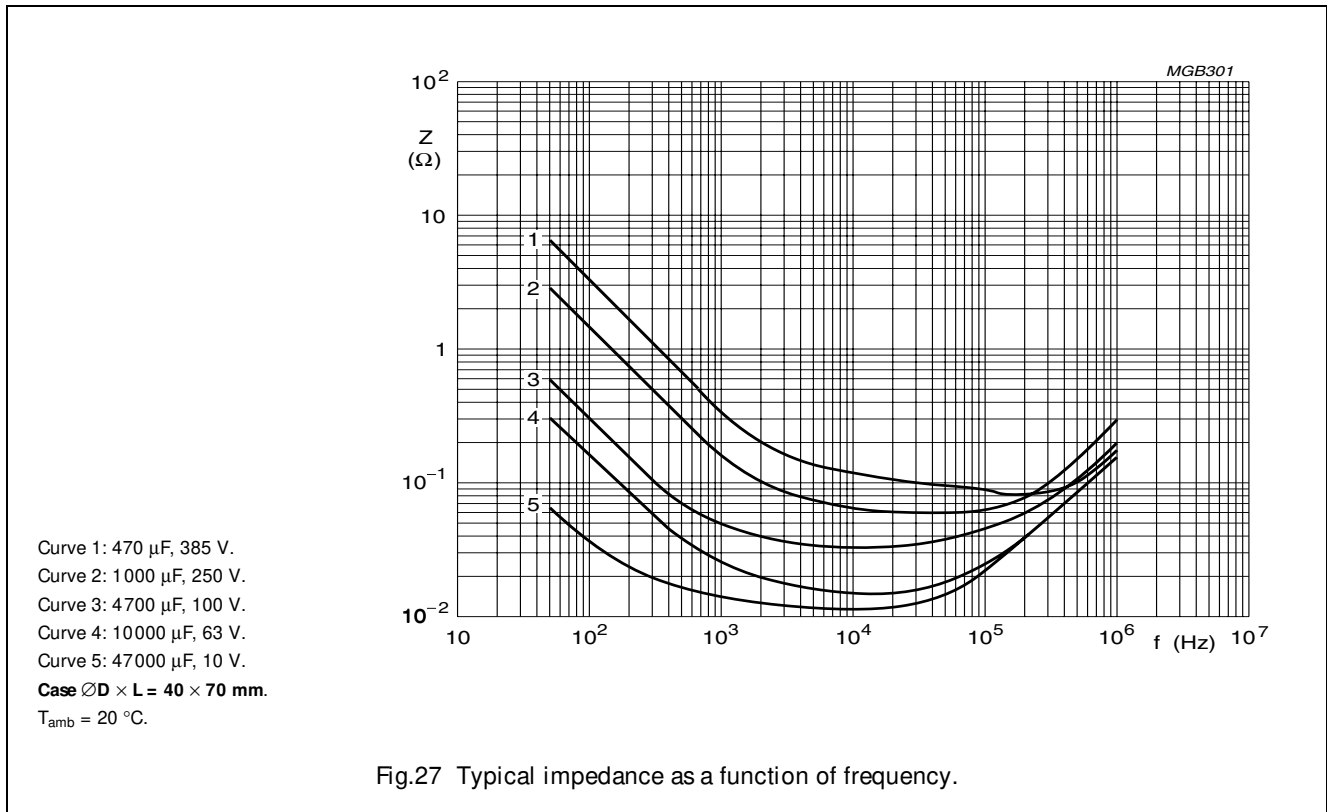
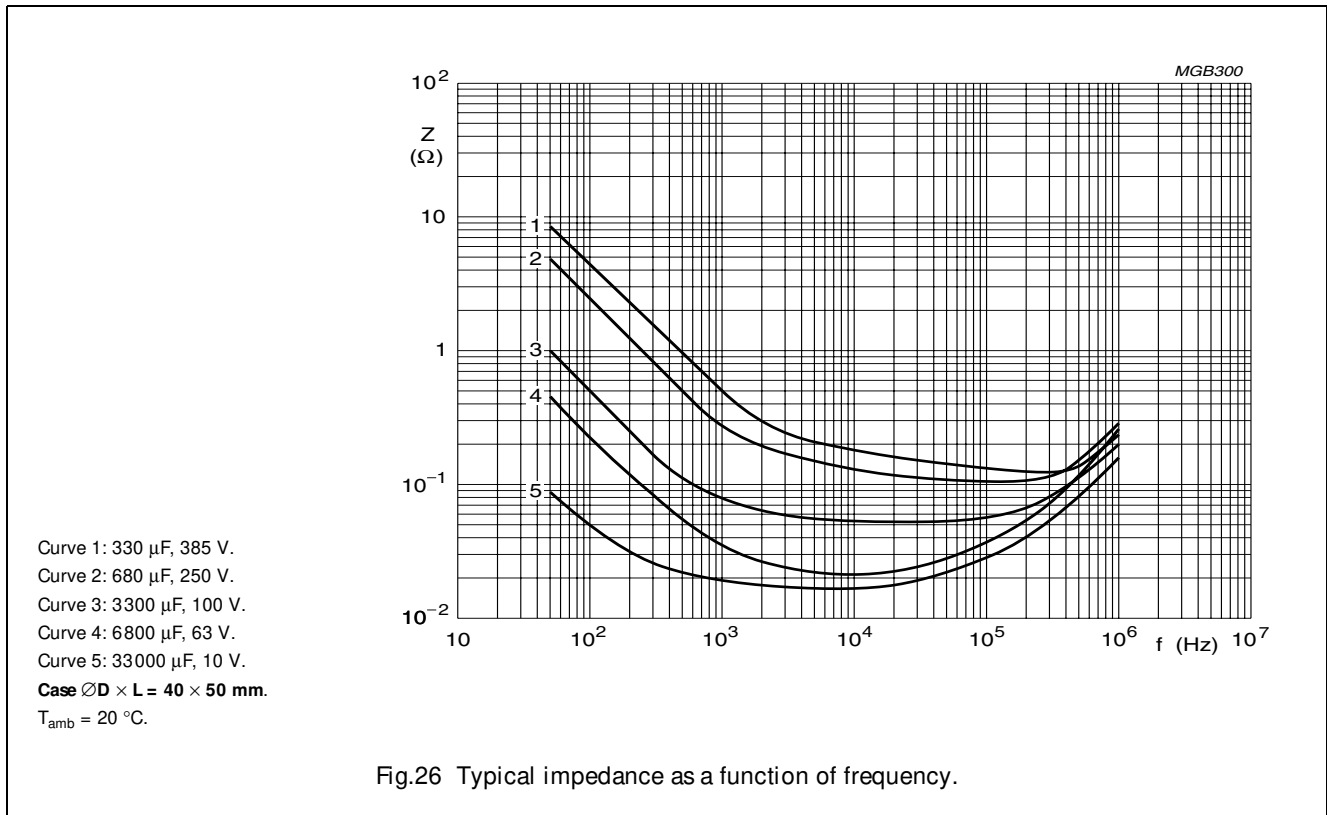

Aluminum electrolytic capacitors

Power Eurodin Printed Wiring

050/052 PED-PW

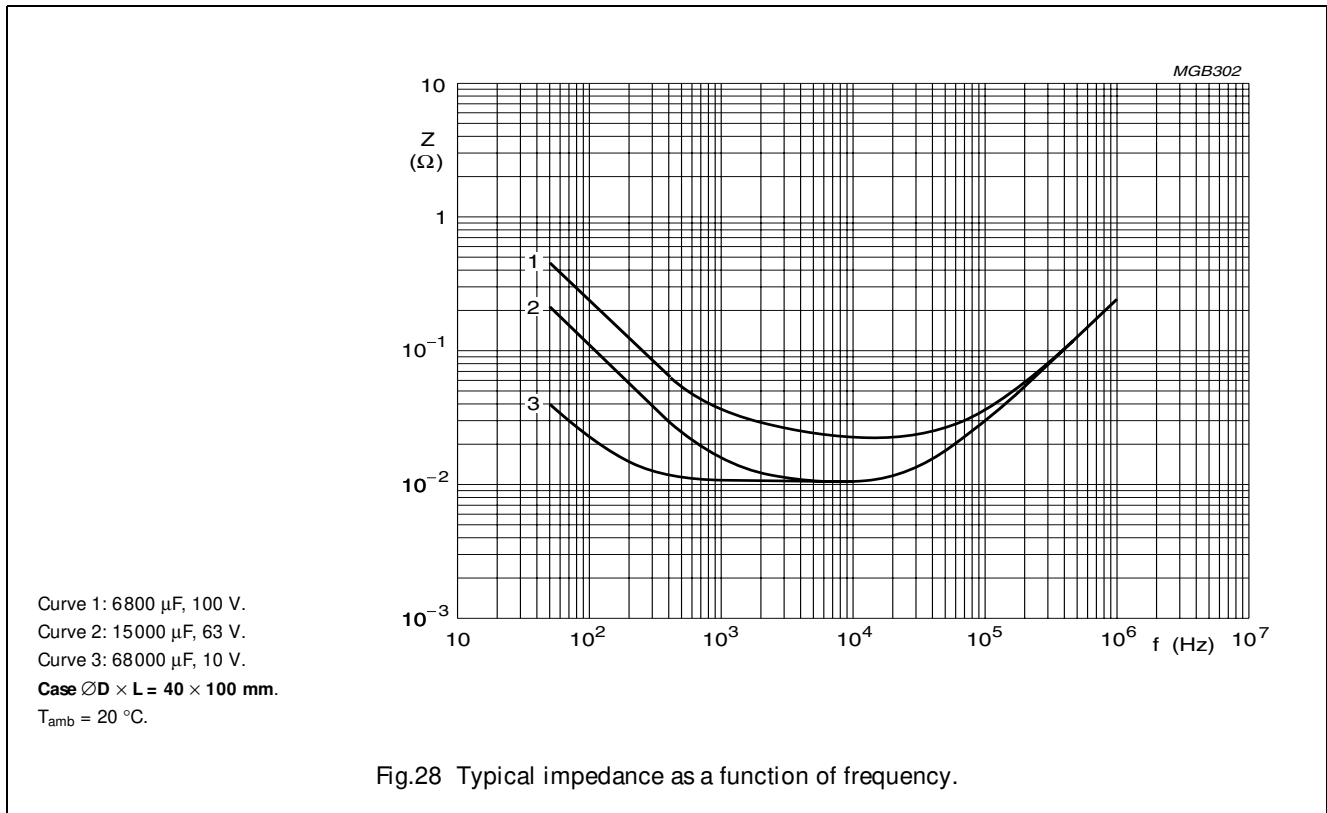

MARKING

The capacitors are marked (where possible) with the following information:

- Rated capacitance (in μF)
- Tolerance on rated capacitance (Q for $-10/+30\%$)
- Rated voltage (in V)
- Climatic category in accordance with "IEC 60068"
- Date code (year and week) in accordance with "IEC 60062"
- Code for factory of origin
- Name of manufacturer
- Polarity of the terminals and '-' sign to indicate the negative terminal, visible from the top and/or side of the capacitor
- Code number.

Aluminum electrolytic capacitors
Power Eurodin Printed Wiring

050/052 PED-PW

RIPPLE CURRENT AND USEFUL LIFE

Table 5 Multiplier of ripple current (I_R) as a function of frequency

FREQUENCY (Hz)	I_R MULTIPLIER
50	0.83
100	1.00
200	1.10
400	1.15
1000	1.19
≥ 2000	1.20

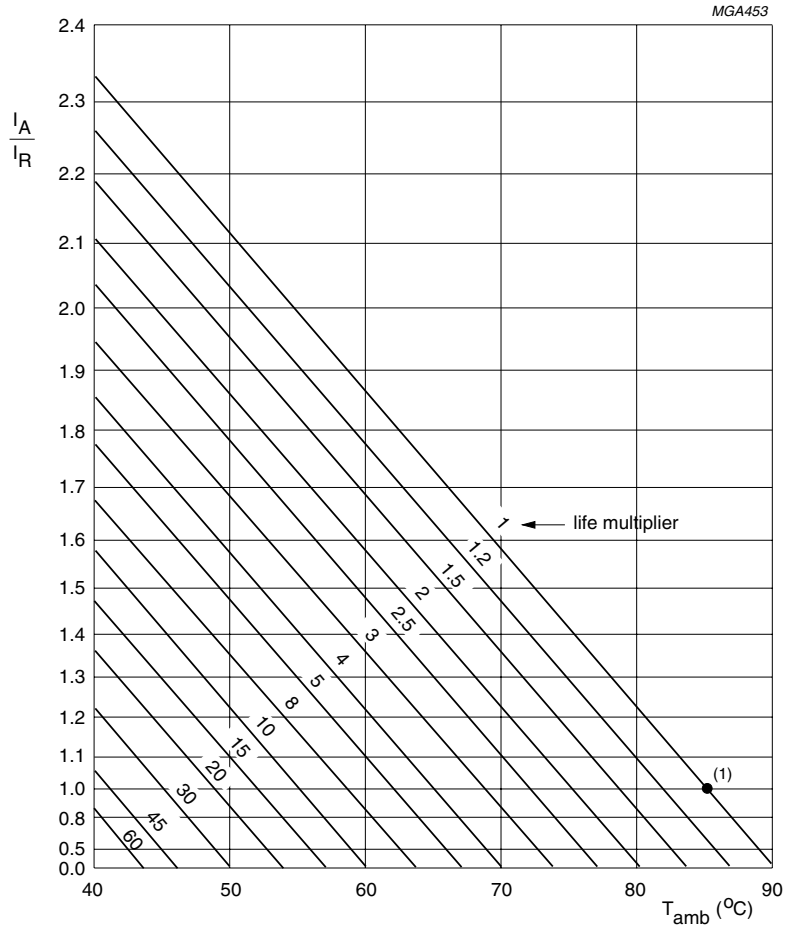

I_A = actual ripple current at 100 Hz.
 I_R = rated ripple current at 100 Hz and 85 °C.
 (1) Useful life at 85 °C and I_R applied: 15000 hours.

Fig.29 Multiplier of useful life as a function of ambient temperature and ripple current load.

Aluminum electrolytic capacitors

Power Eurodin Printed Wiring

050/052 PED-PW

SPECIFIC TESTS AND REQUIREMENTS

General tests and requirements are specified in data handbook BC01, section "Tests and Requirements".

Table 6 Test procedures and requirements

TEST		PROCEDURE (quick reference)	REQUIREMENTS
NAME OF TEST	REFERENCE		
Endurance	IEC 60384-4/ EN130300 subclause 4.13	$T_{amb} = 85\text{ °C}$; U_R applied; 5000 hours	$U_R \leq 100\text{ V}$; $\Delta C/C$: $\pm 15\%$ $U_R > 100\text{ V}$; $\Delta C/C$: $\pm 10\%$ $ESR \leq 1.3 \times \text{spec. limit}$ $Z \leq 2 \times \text{spec. limit}$ $I_{L5} \leq \text{spec. limit}$
Useful life	CECC 30301 subclause 1.8.1	$T_{amb} = 85\text{ °C}$; U_R and I_R applied; 15000 hours	$U_R \leq 100\text{ V}$; $\Delta C/C$: $\pm 45\%$ $U_R > 100\text{ V}$; $\Delta C/C$: $\pm 30\%$ $ESR \leq 3 \times \text{spec. limit}$ $Z \leq 3 \times \text{spec. limit}$ $I_{L5} \leq \text{spec. limit}$ no short or open circuit, no visible damage total failure percentage: $U_R \leq 100\text{ V}$: $\leq 1\%$; $U_R > 100\text{ V}$: $\leq 3\%$
Shelf life (storage at high temperature)	IEC 60384-4/ EN130300 subclause 4.17	$T_{amb} = 85\text{ °C}$; no voltage applied; 500 hours after test: U_R to be applied for 30 minutes, 24 to 48 hours before measurement	$\Delta C/C$: $\pm 10\%$ $ESR \leq 1.2 \times \text{spec. limit}$ $I_{L5} \leq 2 \times \text{spec. limit}$

DATA SHEET

051/053 PEC-PW

Aluminum electrolytic capacitors
Power Economic Printed Wiring

Product specification
Supersedes data of 18th January 2000
File under BCcomponents, BC01

2001 Dec 10

Aluminum electrolytic capacitors Power Economic Printed Wiring

051/053 PEC-PW

FEATURES

- Polarized aluminum electrolytic capacitors, non-solid electrolyte
- Large types with reduced dimensions, cylindrical aluminum case, insulated with a blue sleeve
- Provided with keyed polarity
- Long useful life: 12000 hours at 85 °C
- High ripple current capability
- High resistance to shock and vibration.

APPLICATIONS

- General purpose, industrial and audio/video systems
- Smoothing and filtering
- Standard and switched mode power supplies
- Energy storage in pulse systems.

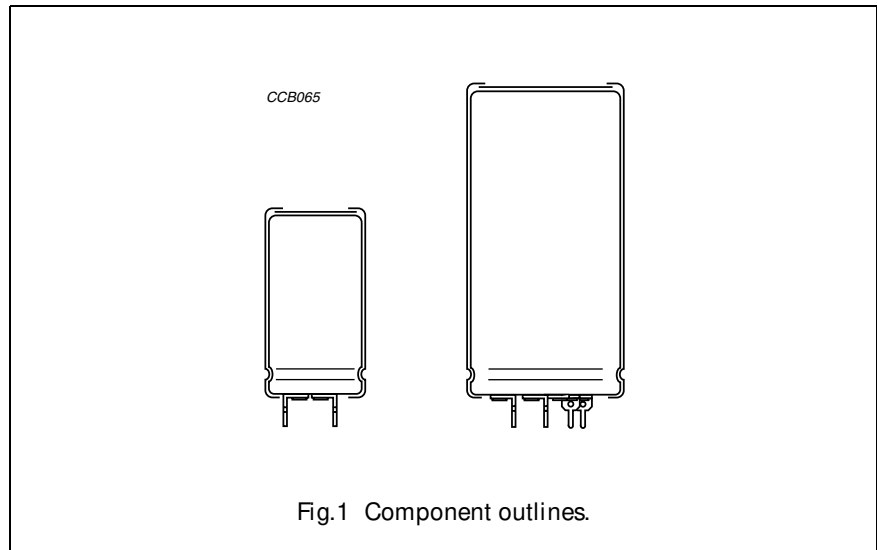
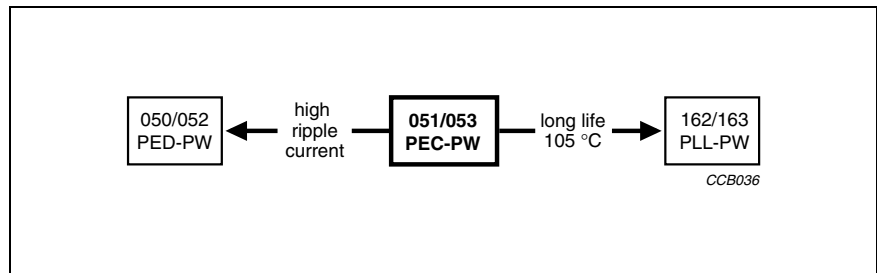

Fig.1 Component outlines.



QUICK REFERENCE DATA

DESCRIPTION	VALUE	
	051	053
Case size ($\varnothing D_{nom} \times L_{nom}$ in mm)	25 × 30 to 40 × 100	
Rated capacitance range (E6 series), C_R	680 to 150000 μF	68 to 2200 μF
Tolerance on C_R	±20%	
Rated voltage range, U_R	10 to 100 V	200 to 400 V
Category temperature range	-40 to +85 °C	
Endurance test at 85 °C	5000 hours	
Useful life at 85 °C	12000 hours	
Useful life at 40 °C, $1.4 \times I_R$ applied	200000 hours	
Shelf life at 0 V, 85 °C	500 hours	
Based on sectional specification	IEC 60384-4/EN130300	
Climatic category IEC 60068	40/085/56	

Aluminum electrolytic capacitors

Power Economic Printed Wiring

05 1/0 53 PEG-PW

Selection chart for C_R , U_R and relevant nominal case sizes ($\varnothing D \times L$ in mm)

Preferred types in **bold**

C_R (μF)	U_R (V)								
	10	16	25	40	63	100	200	385	400
68	–	–	–	–	–	–	–	25 × 30	25 × 30
100	–	–	–	–	–	–	–	25 × 40	25 × 40
150	–	–	–	–	–	–	25 × 30	30 × 40	30 × 40
220	–	–	–	–	–	–	25 × 40	35 × 40	35 × 40
330	–	–	–	–	–	–	30 × 40	35 × 50	35 × 50
	–	–	–	–	–	–	–	40 × 40	40 × 40
470	–	–	–	–	–	–	35 × 40	40 × 50	40 × 50
680	–	–	–	–	–	25 × 30	35 × 50	40 × 70	40 × 70
	–	–	–	–	–	–	40 × 40	–	–
1000	–	–	–	–	–	25 × 40	40 × 50	40 × 100	40 × 100
1500	–	–	–	–	–	30 × 40	40 × 70	–	–
2200	–	–	–	–	25 × 30	35 × 40	40 × 100	–	–
3300	–	–	–	25 × 30	25 × 40	35 × 50	–	–	–
	–	–	–	–	–	40 × 40	–	–	–
4700	–	–	25 × 30	25 × 40	30 × 40	40 × 50	–	–	–
6800	–	25 × 30	25 × 40	30 × 40	35 × 40	40 × 70	–	–	–
10000	25 × 30	25 × 40	30 × 40	35 × 40	35 × 50	40 × 100	–	–	–
	–	–	–	–	40 × 40	–	–	–	–
15000	25 × 40	30 × 40	35 × 40	35 × 50	40 × 70	–	–	–	–
	–	–	–	40 × 40	–	–	–	–	–
22000	30 × 40	35 × 40	35 × 50	40 × 50	40 × 100	–	–	–	–
	–	–	40 × 40	–	–	–	–	–	–
33000	35 × 40	35 × 50	40 × 50	40 × 70	–	–	–	–	–
	–	40 × 40	–	–	–	–	–	–	–
47000	35 × 50	40 × 50	40 × 70	40 × 100	–	–	–	–	–
	40 × 40	–	–	–	–	–	–	–	–
68000	40 × 50	40 × 70	40 × 100	–	–	–	–	–	–
100000	40 × 70	40 × 100	–	–	–	–	–	–	–
150000	40 × 100	–	–	–	–	–	–	–	–

Aluminum electrolytic capacitors Power Economic Printed Wiring

05 1/053 PEG-PW

MECHANICAL DATA AND PACKAGING QUANTITIES

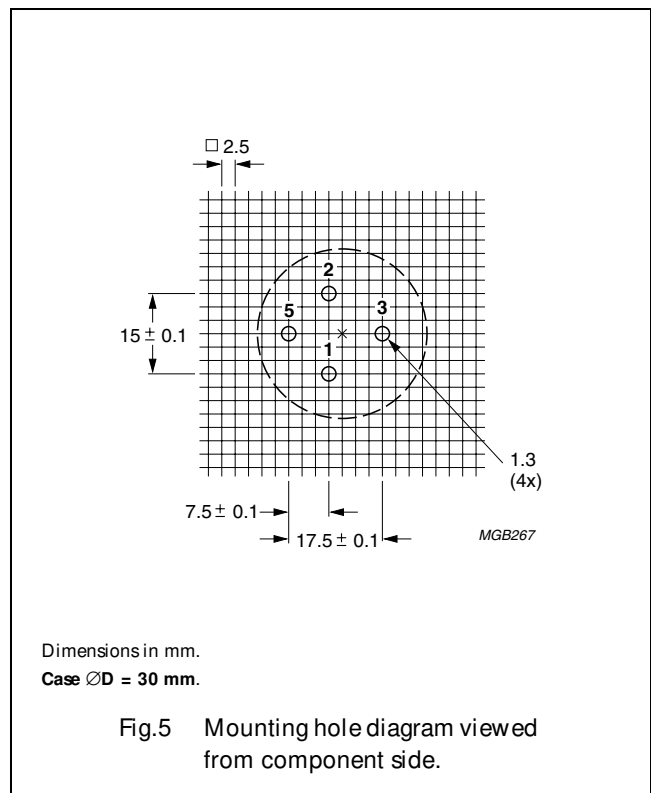
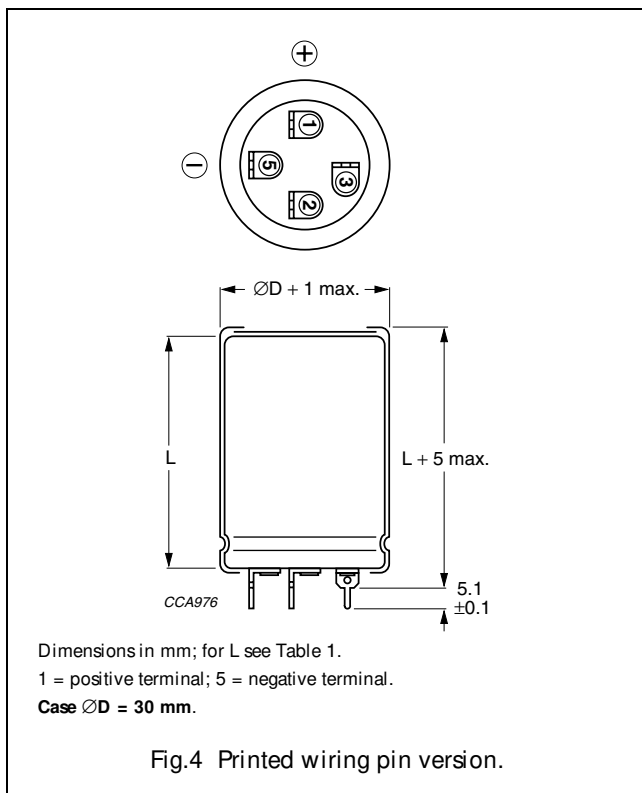
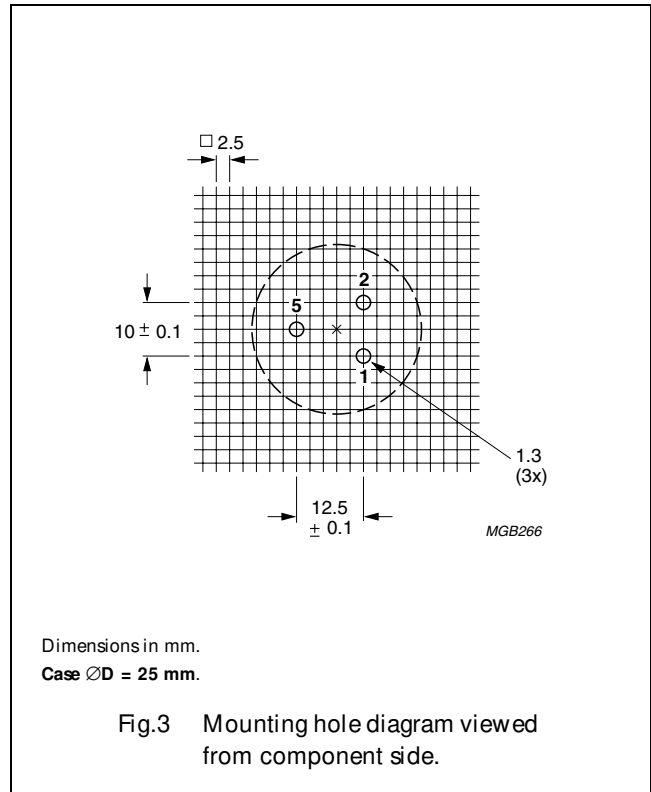
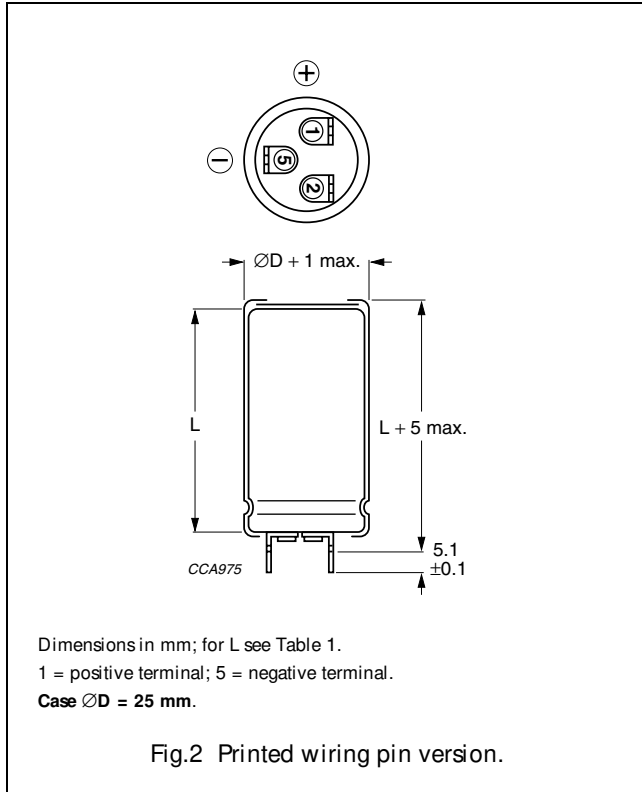

Aluminum electrolytic capacitors Power Economic Printed Wiring

05 1/053 PEG-PW

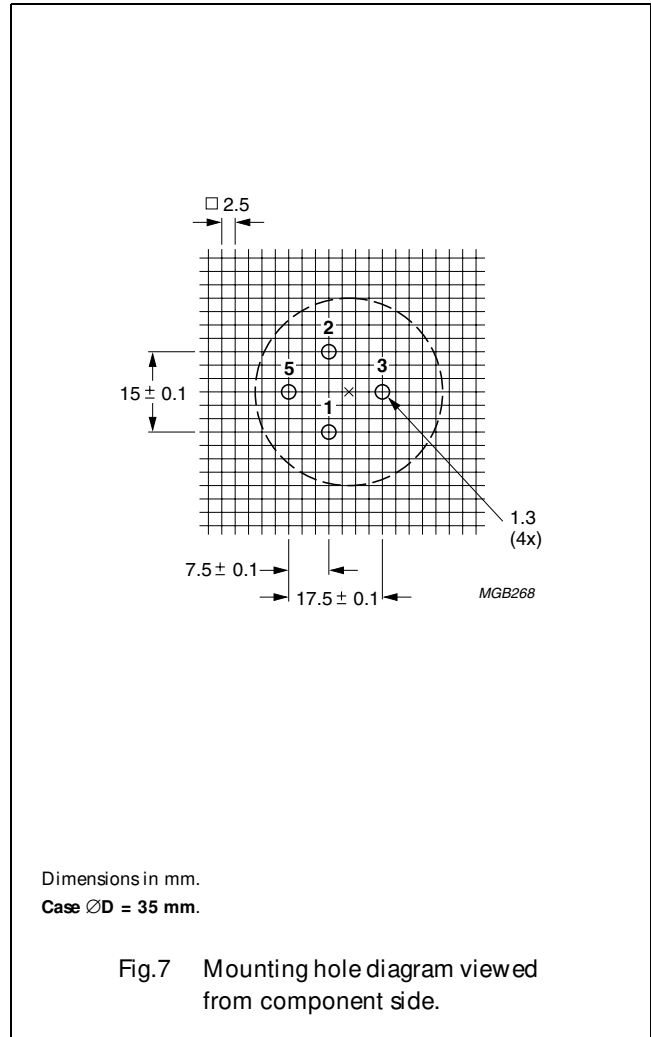
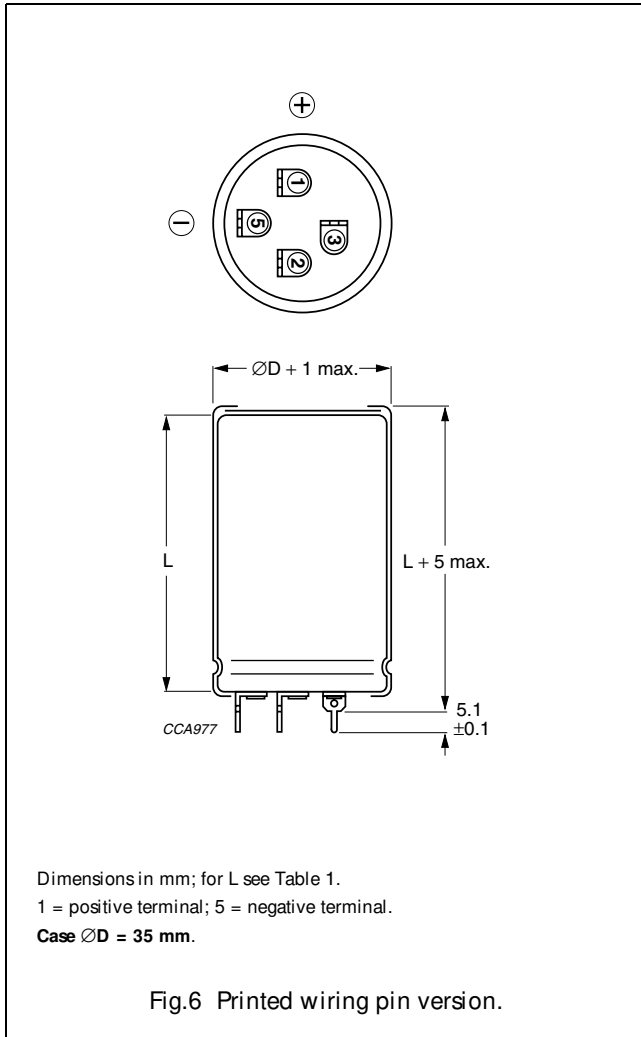
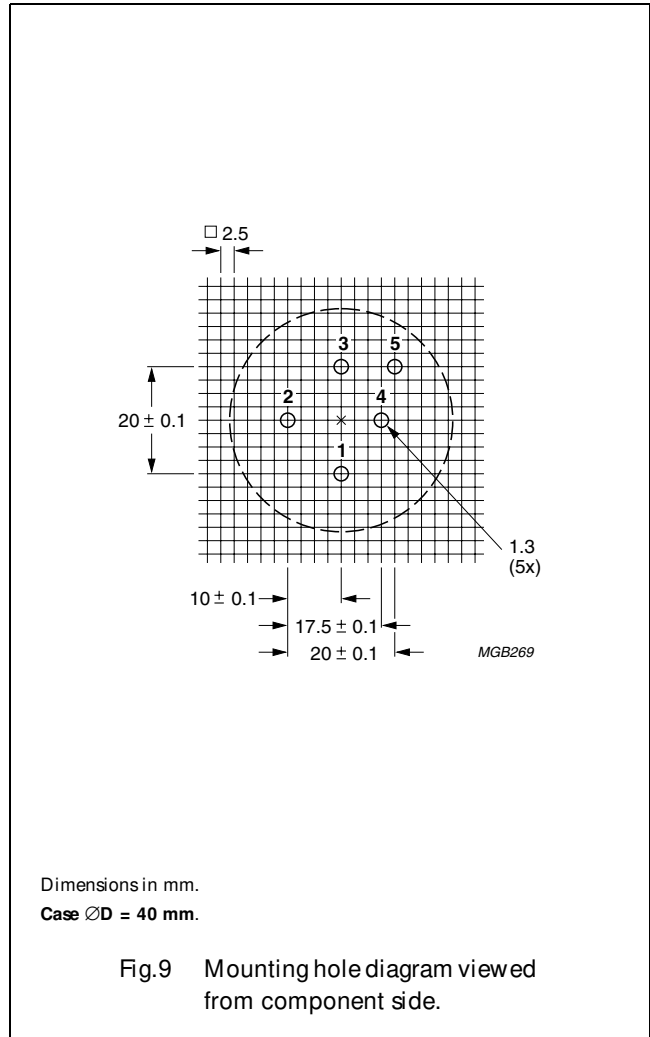
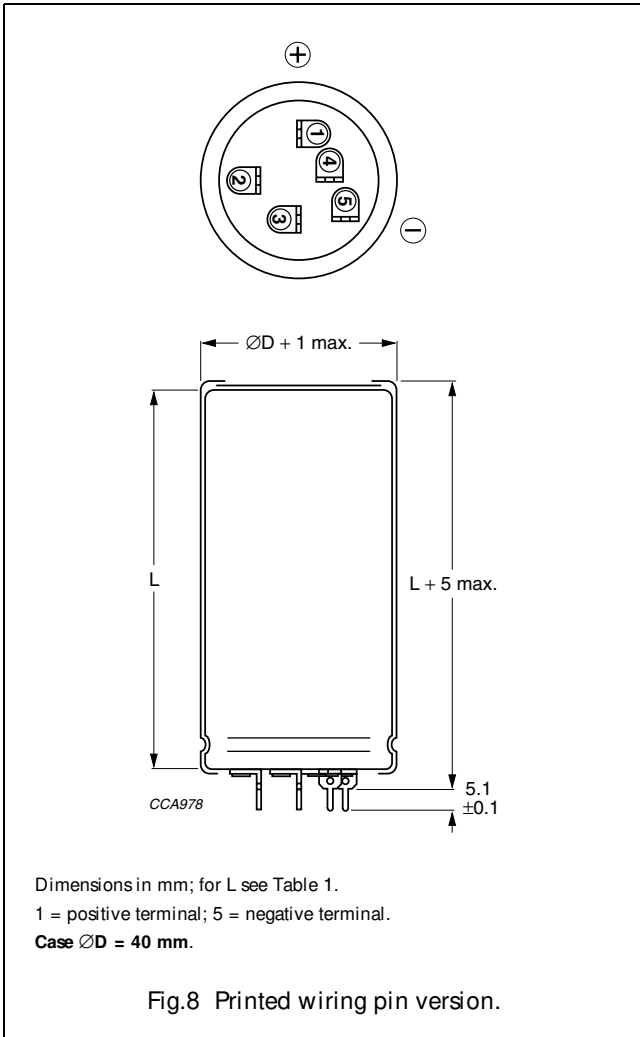

Table 1 Physical dimensions, mass and packaging information; see Figs 2, 4, 6 and 8

NOMINAL CASE SIZE ØD × L (mm)	ØD _{max} (mm)	L _{max} (mm)	MASS (g)	PACKAGING QUANTITIES (units per box)	CARD BOARD BOX DIMENSIONS l × w × h (mm)
25 × 30	26	35	≈24	100	290 × 280 × 50
25 × 40	26	45	≈28	100	290 × 280 × 60
30 × 40	31	45	≈38	100	340 × 330 × 60
35 × 40	36	45	≈51	50	390 × 198 × 60
35 × 50	36	55	≈66	50	390 × 198 × 70
40 × 40	41	45	≈78	50	440 × 223 × 60
40 × 50	41	55	≈82	50	440 × 223 × 70
40 × 70	41	75	≈110	50	440 × 223 × 90
40 × 100	41	105	≈176	50	440 × 223 × 120

Aluminum electrolytic capacitors Power Economic Printed Wiring

05 1/0 53 PEG-PW



Mounting

When a number of capacitors are connected in a bank, they must not be closer together than 15 mm, when no derating of ripple current and/or temperature is applied.

Pin numbers 2, 3 and 4 (if present) must be free from the electrical circuit.

MARKING

The capacitors are marked (where possible) with the following information:

- Rated capacitance (in µF)
- Tolerance on rated capacitance (M for ±20%)

- Rated voltage (in V)
- Climatic category in accordance with "IEC 60068"
- Date code (year and week) in accordance with "IEC 60062"
- Code for factory of origin
- Name of manufacturer
- Polarity of the terminals and '-' sign to indicate the negative terminal, visible from the top and/or side of the capacitor
- Code number.

Aluminum electrolytic capacitors

Power Economic Printed Wiring

05 1/0 53 PEG-PW

ELECTRICAL DATA AND ORDERING INFORMATION

Unless otherwise specified, all electrical values in Tables 2 and 3 apply at $T_{amb} = 20\text{ °C}$, $P = 86$ to 106 kPa , $RH = 45$ to 75% .

SYMBOL	DESCRIPTION
C_R	rated capacitance at 100 Hz
I_R	rated RMS ripple current at 100 Hz, 85 °C or at 20 kHz, 70 °C
I_{L1}	max. leakage current after 1 minute at U_R
I_{L5}	max. leakage current after 5 minutes at U_R
ESR	max. equivalent series resistance at 100 Hz
Z	max. impedance at 10 kHz

Ordering example

Electrolytic capacitor 051 series

10000 $\mu\text{F}/25\text{ V}$; $\pm 20\%$ Nominal case size: $\varnothing 30 \times 40\text{ mm}$

Catalogue number: 2222 051 56103.

Table 2 Electrical data and ordering information for **051** series; preferred types in **bold**

U_R (V)	C_R 100 Hz (μF)	NOMINAL CASE SIZE $\varnothing D \times L$ (mm)	I_R 100 Hz 85 °C (A)	I_R 20 kHz 70 °C (A)	I_{L1} 1 min (mA)	I_{L5} 5 min (mA)	ESR 100 Hz (m Ω)	Z 10 kHz (m Ω)	CATALOGUE NUMBER 2222
10	10000	25 × 30	3.1	5.9	0.60	0.20	51	40	051 54103
	15000	25 × 40	4.1	7.8	0.90	0.30	37	30	051 54153
	22000	30 × 40	5.0	9.5	1.32	0.44	30	25	051 54223
	33000	35 × 40	5.5	10.4	1.98	0.66	28	24	051 54333
	47000	35 × 50	6.8	12.9	2.82	0.94	23	20	051 54473
	47000	40 × 40	5.8	10.4	2.82	0.94	29	22	051 44473
	68000	40 × 50	7.1	13.5	4.08	1.36	24	20	051 54683
	100000	40 × 70	9.2	17.4	6.00	2.00	19	16	051 54104
150000	40 × 100	12.0	22.7	9.00	3.00	16	14	051 54154	
16	6800	25 × 30	3.1	5.9	0.65	0.22	53	42	051 55682
	10000	25 × 40	4.0	7.6	0.96	0.32	39	34	051 55103
	15000	30 × 40	5.0	9.5	1.44	0.48	31	27	051 55153
	22000	35 × 40	5.5	10.4	2.12	0.71	29	26	051 55223
	33000	35 × 50	6.7	12.7	3.17	1.06	23	21	051 55333
	33000	40 × 40	5.7	10.8	3.17	1.06	30	24	051 45333
	47000	40 × 50	7.0	13.3	4.52	1.51	24	20	051 55473
	68000	40 × 70	9.2	17.4	6.53	2.18	19	16	051 55683
100000	40 × 100	12.0	22.7	9.60	3.20	16	14	051 55104	
25	4700	25 × 30	2.9	5.5	0.71	0.24	60	42	051 56472
	6800	25 × 40	3.9	7.4	1.02	0.34	42	34	051 56682
	10000	30 × 40	4.8	9.1	1.50	0.50	34	27	051 56103
	15000	35 × 40	5.3	10.0	2.25	0.75	30	26	051 56153
	22000	35 × 50	6.5	12.3	3.30	1.10	24	21	051 56223
	22000	40 × 40	5.7	10.8	3.30	1.10	31	24	051 46223
	33000	40 × 50	7.0	13.3	4.95	1.65	25	20	051 56333
	47000	40 × 70	9.2	17.4	7.05	2.35	19	16	051 56473
68000	40 × 100	12.0	22.7	10.20	3.40	16	14	051 56683	

Aluminum electrolytic capacitors

Power Economic Printed Wiring

05 1/0 53 PEG-PW

U_R (V)	C_R 100 Hz (μF)	NOMINAL CASE SIZE $\varnothing D \times L$ (mm)	I_R 100 Hz 85 °C (A)	I_R 20 kHz 70 °C (A)	I_{L1} 1 min (mA)	I_{L5} 5 min (mA)	ESR 100 Hz (m Ω)	Z 10 kHz (m Ω)	CATALOGUE NUMBER 2222
40	3300	25 × 30	2.9	5.5	0.80	0.27	87	63	051 57332
	4700	25 × 40	3.8	7.2	1.13	0.38	62	47	051 57472
	6800	30 × 40	4.7	8.9	1.64	0.55	49	38	051 57682
	10000	35 × 40	5.2	9.8	2.40	0.80	48	37	051 57103
	15000	35 × 50	6.3	11.9	3.60	1.20	37	28	051 57153
	15000	40 × 40	5.6	10.6	3.60	1.20	50	35	051 47153
	22000	40 × 50	5.8	11.0	5.28	1.76	39	28	051 57223
	33000	40 × 70	7.8	14.8	7.92	2.64	28	21	051 57333
	47000	40 × 100	10.4	19.7	11.28	3.76	22	17	051 57473
63	2200	25 × 30	2.5	4.7	0.84	0.28	83	62	051 58222
	3300	25 × 40	3.3	6.2	1.25	0.42	58	42	051 58332
	4700	30 × 40	4.1	7.8	1.78	0.60	49	38	051 58472
	6800	35 × 40	4.5	8.5	2.57	0.86	48	37	051 58682
	10000	35 × 50	5.4	10.2	3.78	1.26	37	28	051 58103
	10000	40 × 40	4.6	8.7	3.78	1.26	52	37	051 48103
	15000	40 × 70	7.5	14.2	5.67	1.89	29	24	051 58153
	22000	40 × 100	10.0	19.0	8.32	2.77	22	19	051 58223
	100	680	25 × 30	1.74	3.30	0.41	0.14	190	130
1000		25 × 40	2.34	4.44	0.60	0.20	130	90	051 59102
1500		30 × 40	2.95	5.59	0.90	0.30	95	67	051 59152
2200		35 × 40	3.69	7.00	1.32	0.44	71	53	051 59222
3300		35 × 50	4.37	8.29	1.98	0.66	55	41	051 59332
3300		40 × 40	4.16	7.89	1.98	0.66	64	48	051 49332
4700		40 × 50	5.21	9.88	2.82	0.94	49	38	051 59472
6800		40 × 70	6.97	13.22	4.08	1.36	35	28	051 59682
10000		40 × 100	9.50	18.00	6.00	2.00	26	21	051 59103

Aluminum electrolytic capacitors

Power Economic Printed Wiring

05 1/053 PEG-PW

Table 3 Electrical data and ordering information for **053** series; preferred types in **bold**

U_R (V)	C_R 100 Hz (μF)	NOMINAL CASE SIZE $\varnothing D \times L$ (mm)	I_R 100 Hz 85 °C (A)	I_R 20 kHz 70 °C (A)	I_{L1} 1 min (mA)	I_{L5} 5 min (mA)	ESR 100 Hz (m Ω)	Z 10 kHz (m Ω)	CATALOGUE NUMBER 2222
200	150	25 × 30	0.70	1.33	0.18	0.06	1000	770	053 52151
	220	25 × 40	0.94	1.78	0.26	0.09	680	525	053 52221
	330	30 × 40	1.27	2.41	0.40	0.14	460	360	053 52331
	470	35 × 40	1.66	3.15	0.57	0.19	320	250	053 52471
	680	35 × 50	2.19	4.15	0.82	0.28	220	170	053 52681
	680	40 × 40	2.17	4.11	0.82	0.28	220	170	053 42681
	1000	40 × 50	2.86	5.42	1.20	0.40	150	115	053 52102
	1500	40 × 70	3.81	7.22	1.80	0.60	110	85	053 52152
	2200	40 × 100	5.20	9.86	2.64	0.88	80	60	053 52222
	385	68	25 × 30	0.47	0.89	0.16	0.06	2200	1480
100		25 × 40	0.64	1.21	0.23	0.08	1500	1020	053 58101
150		30 × 40	0.90	1.71	0.35	0.12	1000	700	053 58151
220		35 × 40	1.15	2.18	0.51	0.17	680	480	053 58221
330		35 × 50	1.53	2.90	0.77	0.26	450	340	053 58331
330		40 × 40	1.52	2.88	0.77	0.26	450	340	053 48331
470		40 × 50	1.96	3.72	1.09	0.36	320	260	053 58471
680		40 × 70	2.70	5.12	1.58	0.53	220	190	053 58681
1000		40 × 100	3.70	7.02	2.31	0.78	180	140	053 58102
400		68	25 × 30	0.54	1.02	0.16	0.06	2100	1000
	100	25 × 40	0.73	1.38	0.24	0.08	1400	780	053 56101
	150	30 × 40	0.98	1.86	0.36	0.12	950	520	053 56151
	220	35 × 40	1.28	2.43	0.52	0.17	650	400	053 56221
	330	35 × 50	1.67	3.17	0.79	0.26	480	280	053 56331
	330	40 × 40	1.67	3.17	0.79	0.26	480	280	053 46331
	470	40 × 50	2.12	4.02	1.12	0.37	340	220	053 56471
	680	40 × 70	2.90	5.50	1.63	0.54	235	155	053 56681
	1000	40 × 100	4.05	7.68	2.40	0.80	160	110	053 56102

Aluminum electrolytic capacitors Power Economic Printed Wiring

05 1/0 53 PEG-PW

Additional electrical data

PARAMETER	CONDITIONS	VALUE
Voltage		
Surge voltage	≤250 V versions	$U_s = 1.15 \times U_R$
	≥385 V versions	$U_s = 1.1 \times U_R$
Reverse voltage		$U_{rev} \leq 1 \text{ V}$
Current		
Leakage current	after 1 minute at U_R	$I_{L1} \leq 0.006C_R \times U_R + 4 \mu\text{A}$
	after 5 minutes at U_R	$I_{L5} \leq 0.002C_R \times U_R + 4 \mu\text{A}$
Inductance		
Equivalent series inductance (ESL)	case $\varnothing D = 25 \text{ mm}$	max. 25 nH
	case $\varnothing D = 30 \text{ and } 35 \text{ mm}$	max. 30 nH
	case $\varnothing D = 40 \text{ mm}$	max. 35 nH

Capacitance (C)

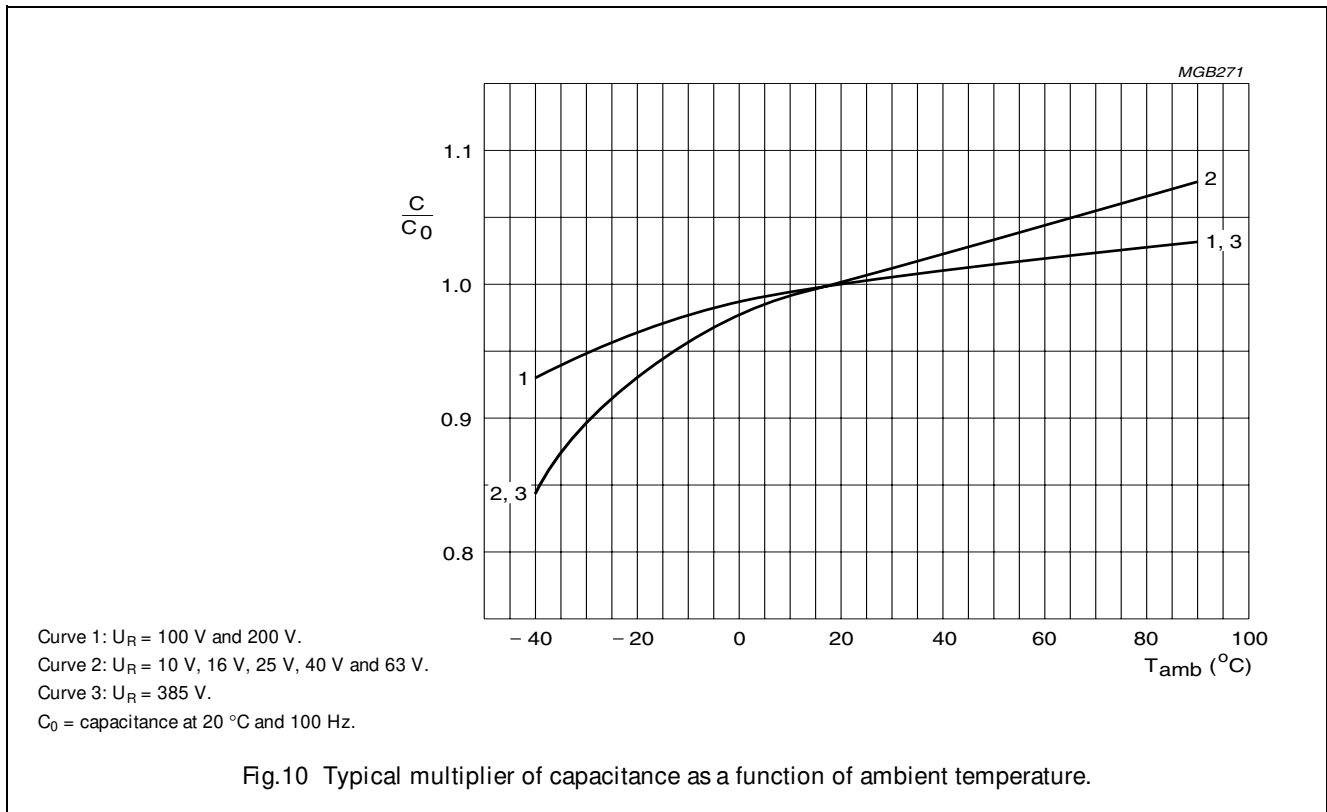

Aluminum electrolytic capacitors
Power Economic Printed Wiring

05 1/053 PEG-PW

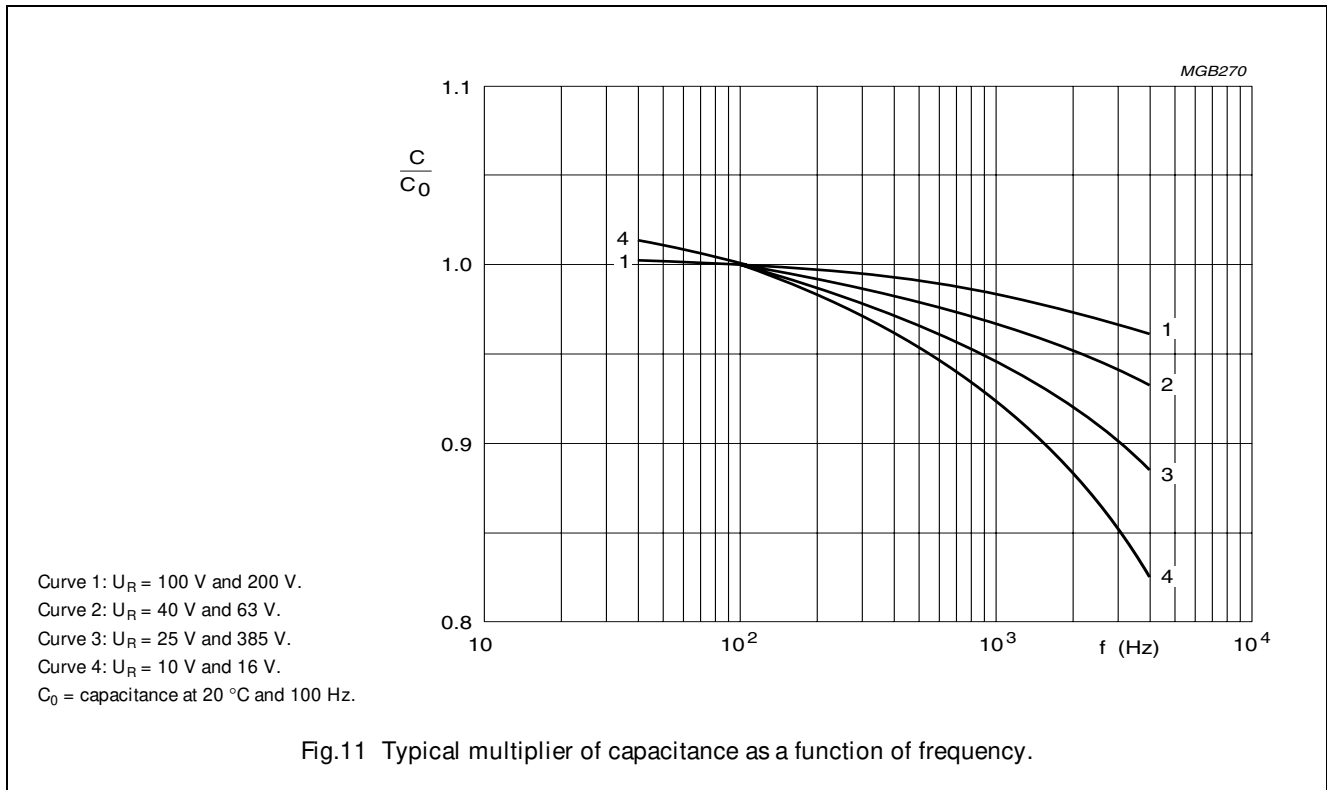

Equivalent series resistance (ESR)

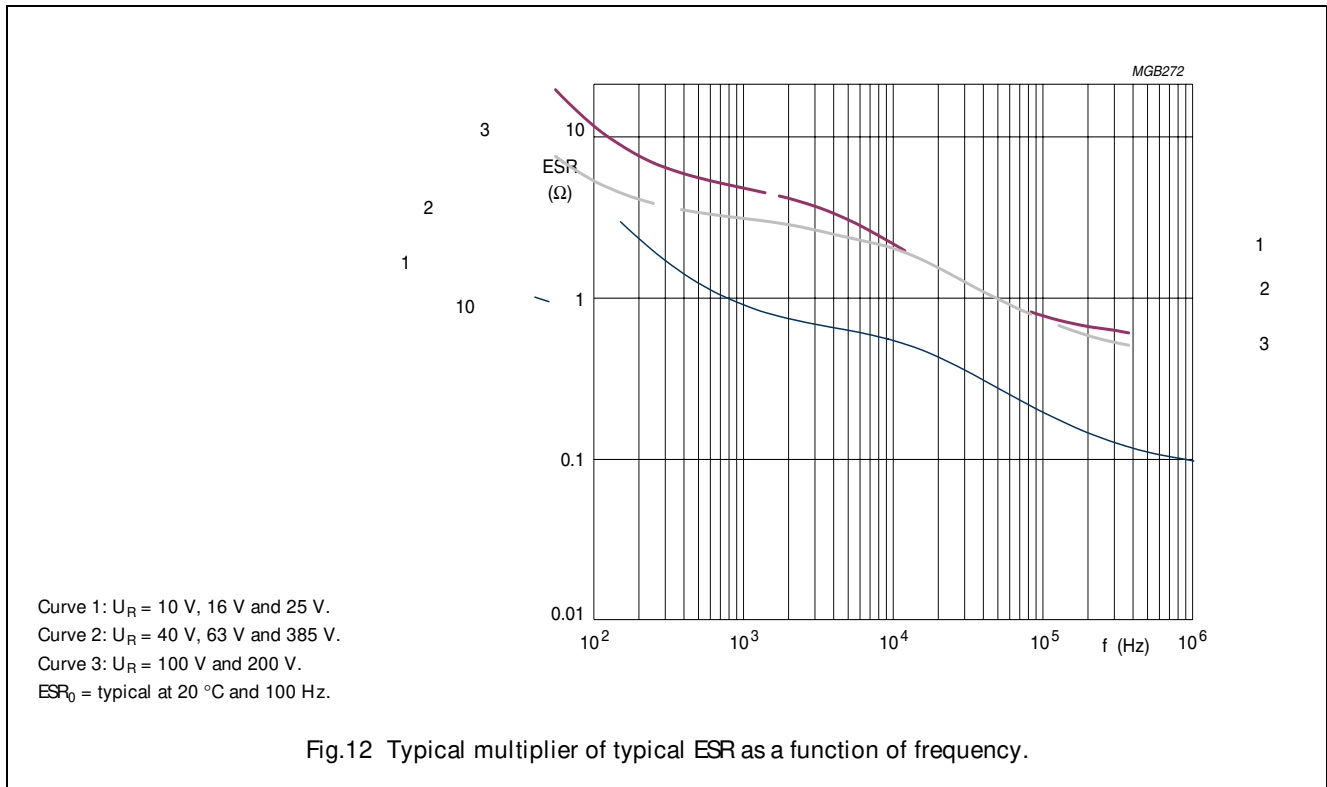

Aluminum electrolytic capacitors
Power Economic Printed Wiring

05 1/053 PEG-PW

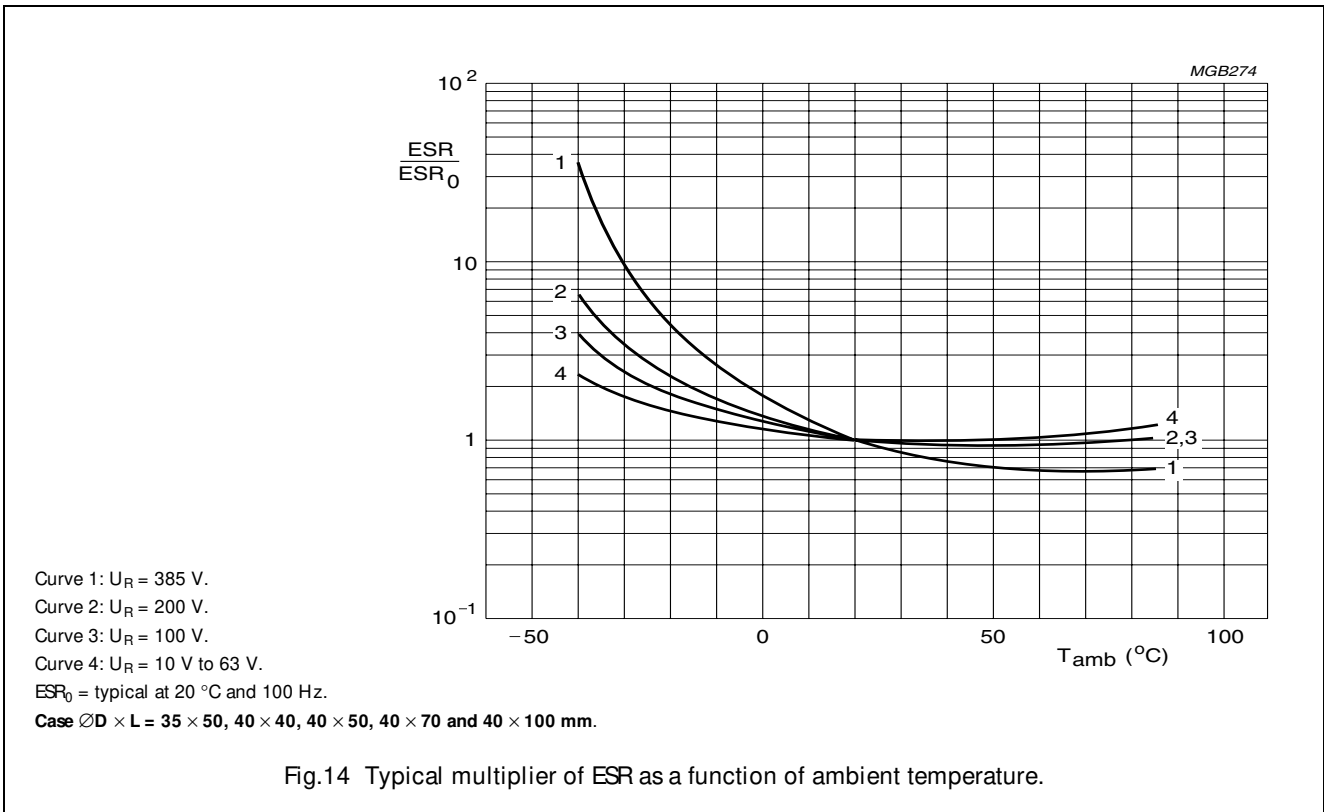
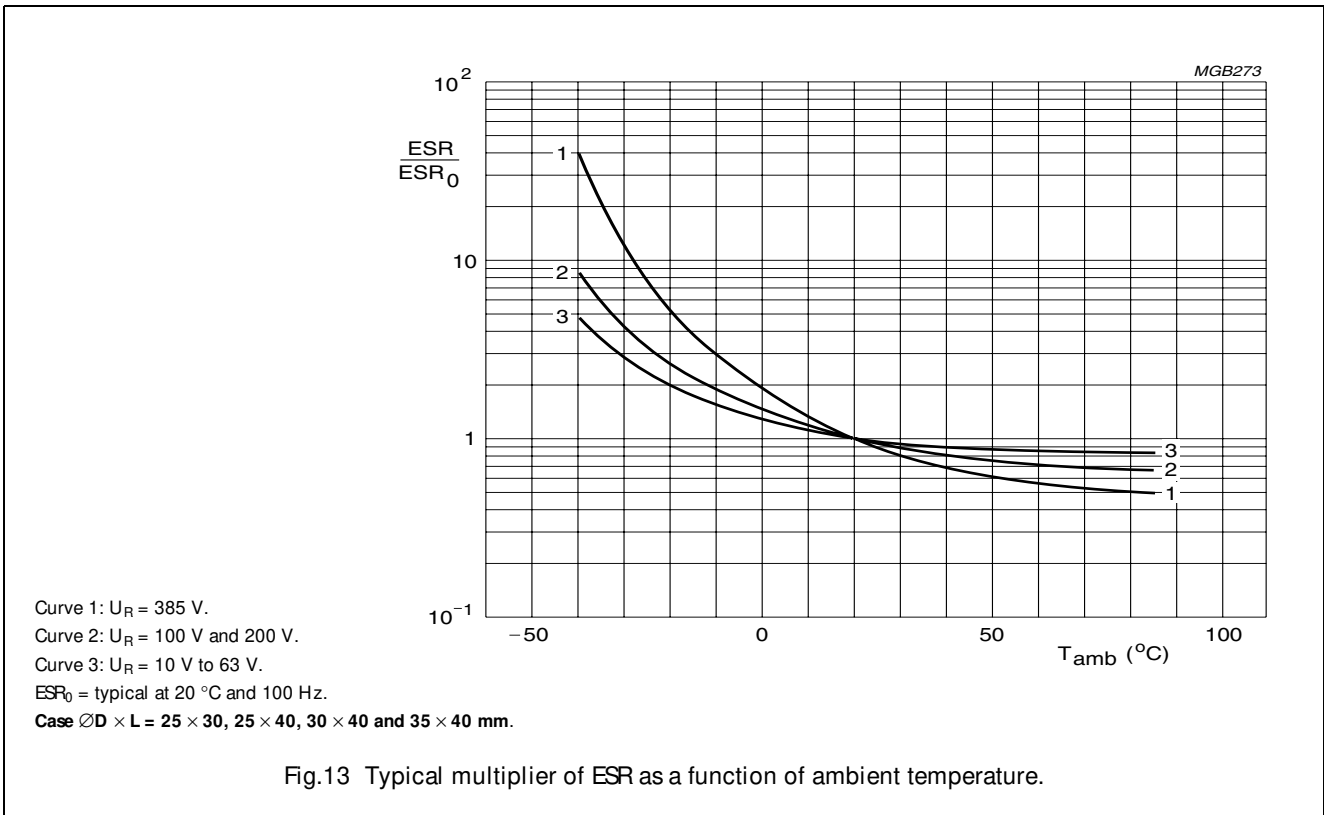

Aluminum electrolytic capacitors Power Economic Printed Wiring

05 1/053 PEG-PW

Impedance (Z)

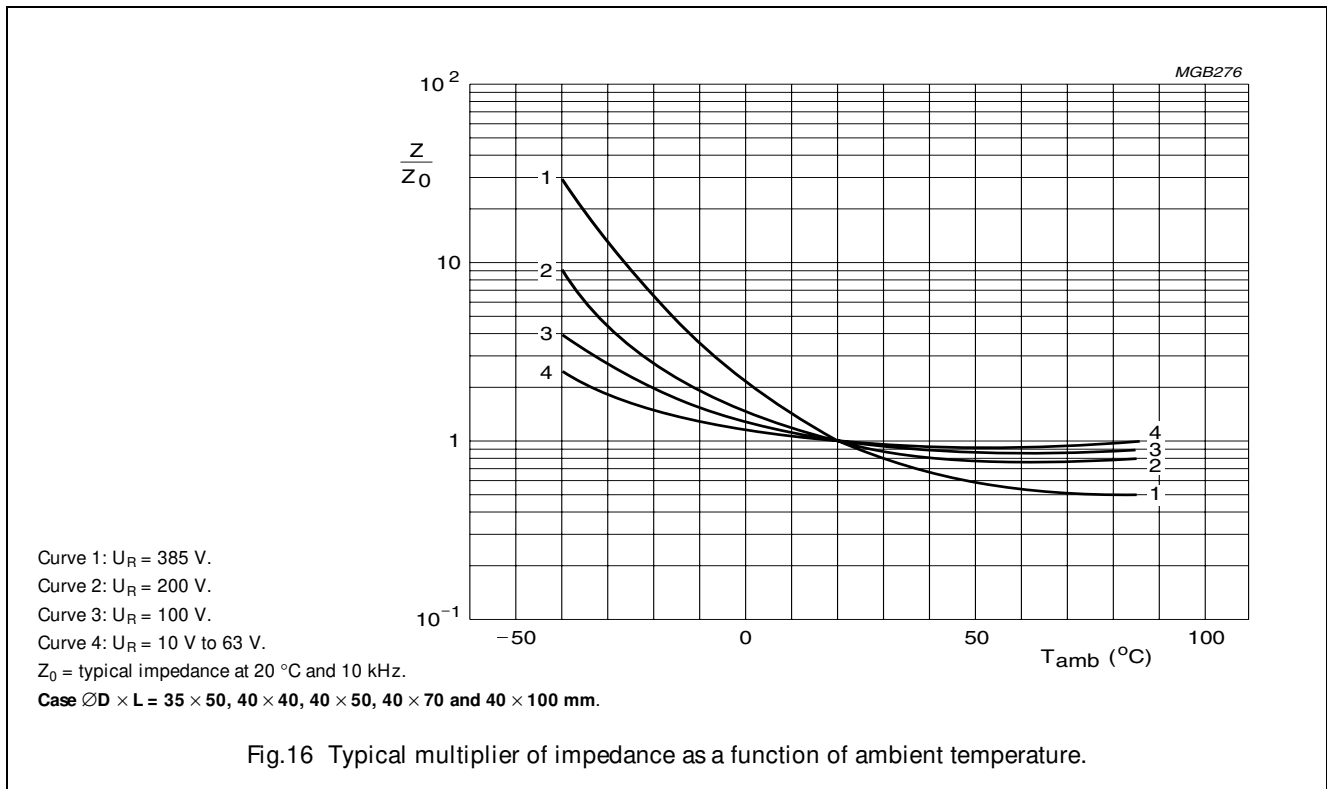
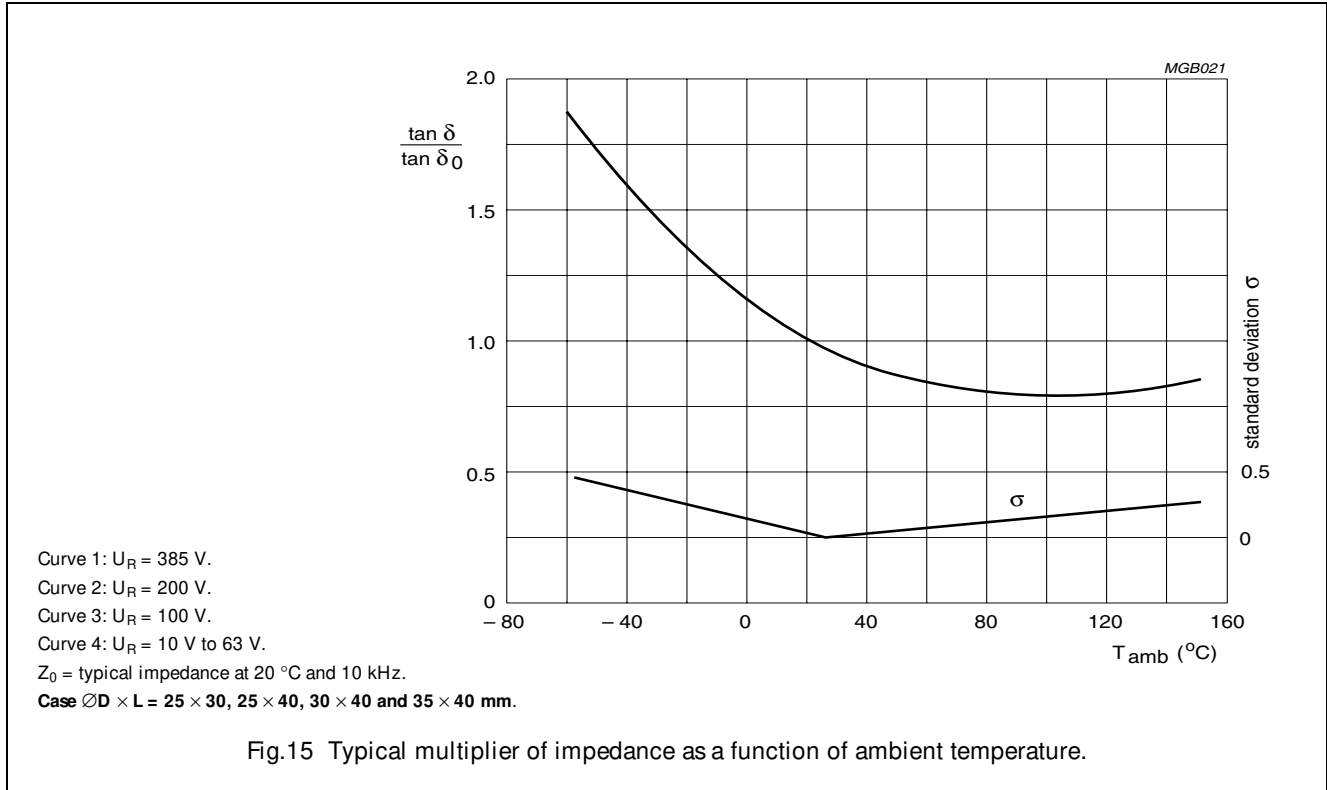

Aluminum electrolytic capacitors
Power Economic Printed Wiring

05 1/053 PEG-PW

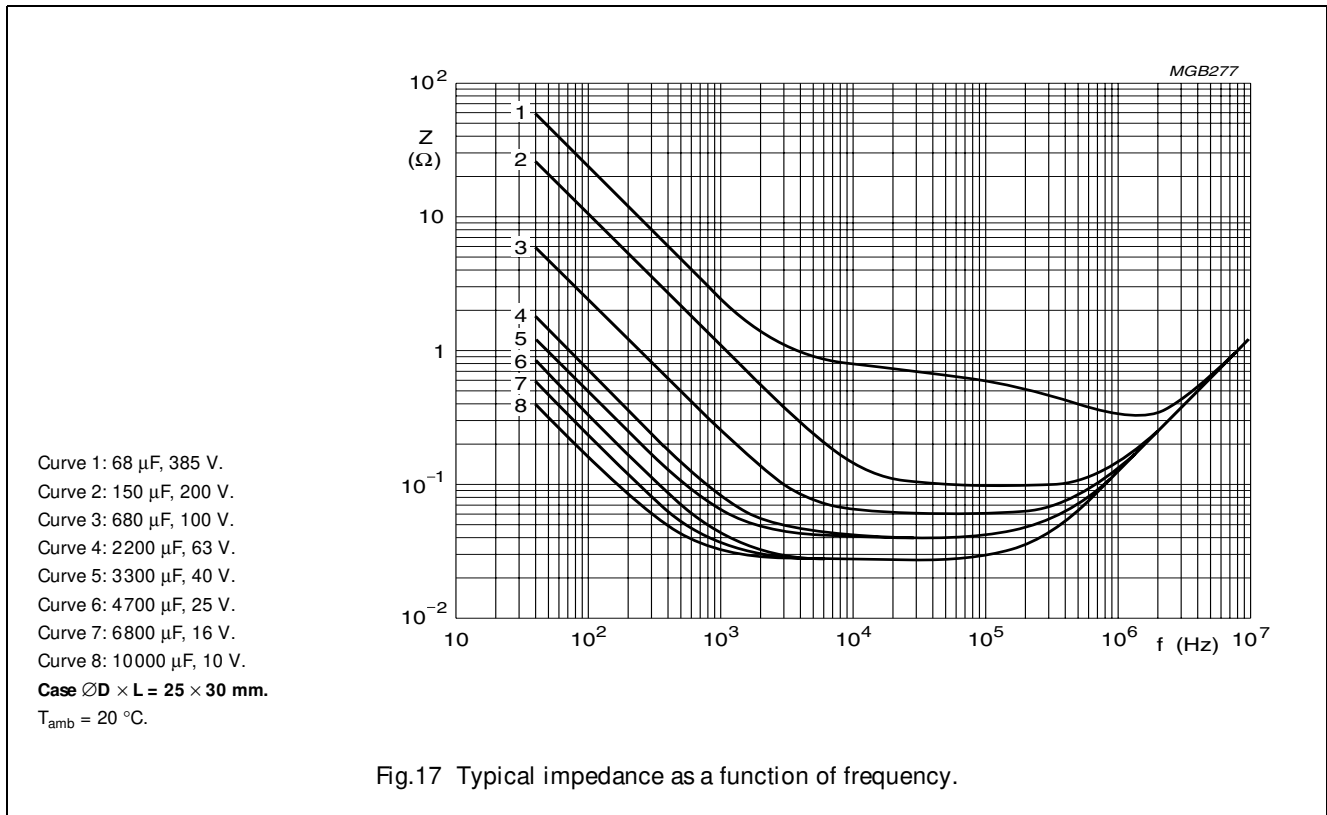

Fig.17 Typical impedance as a function of frequency.

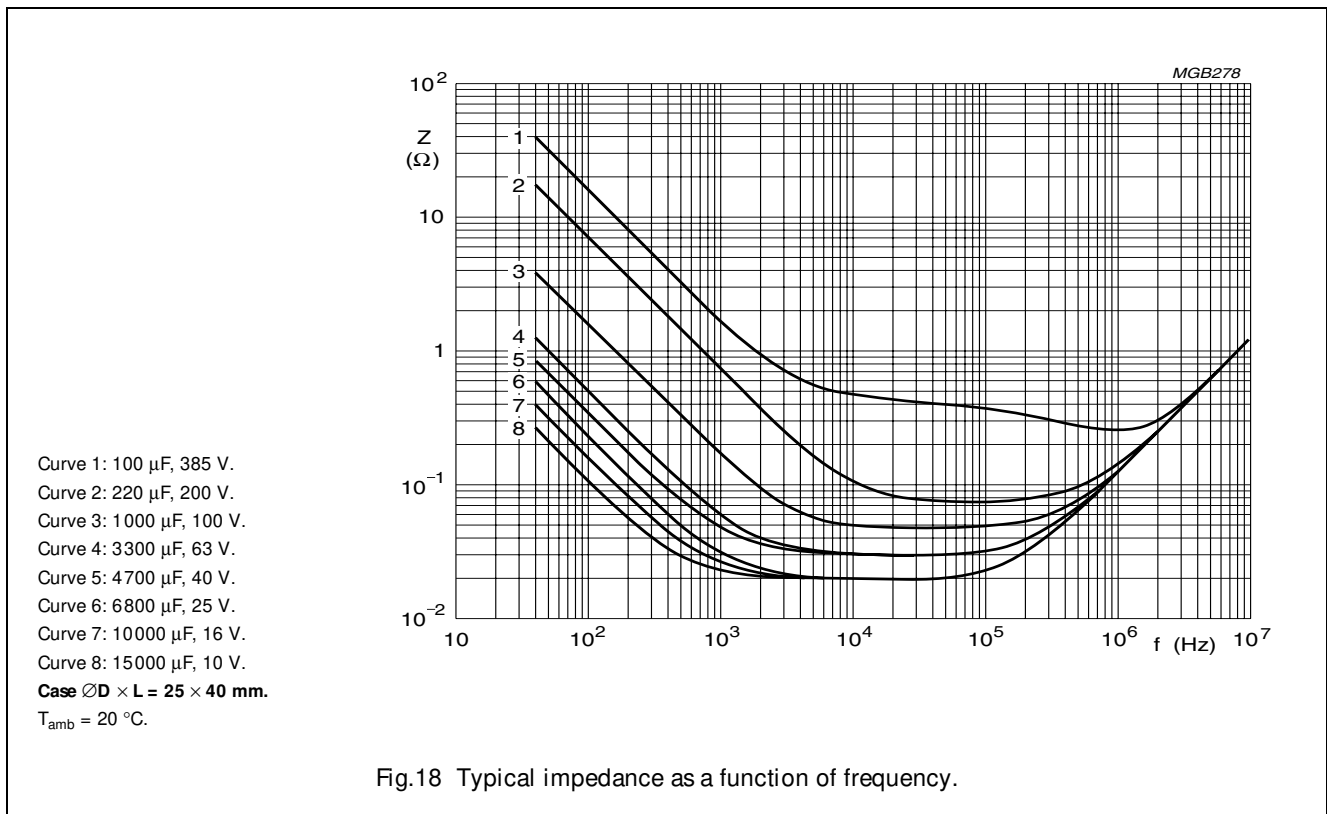
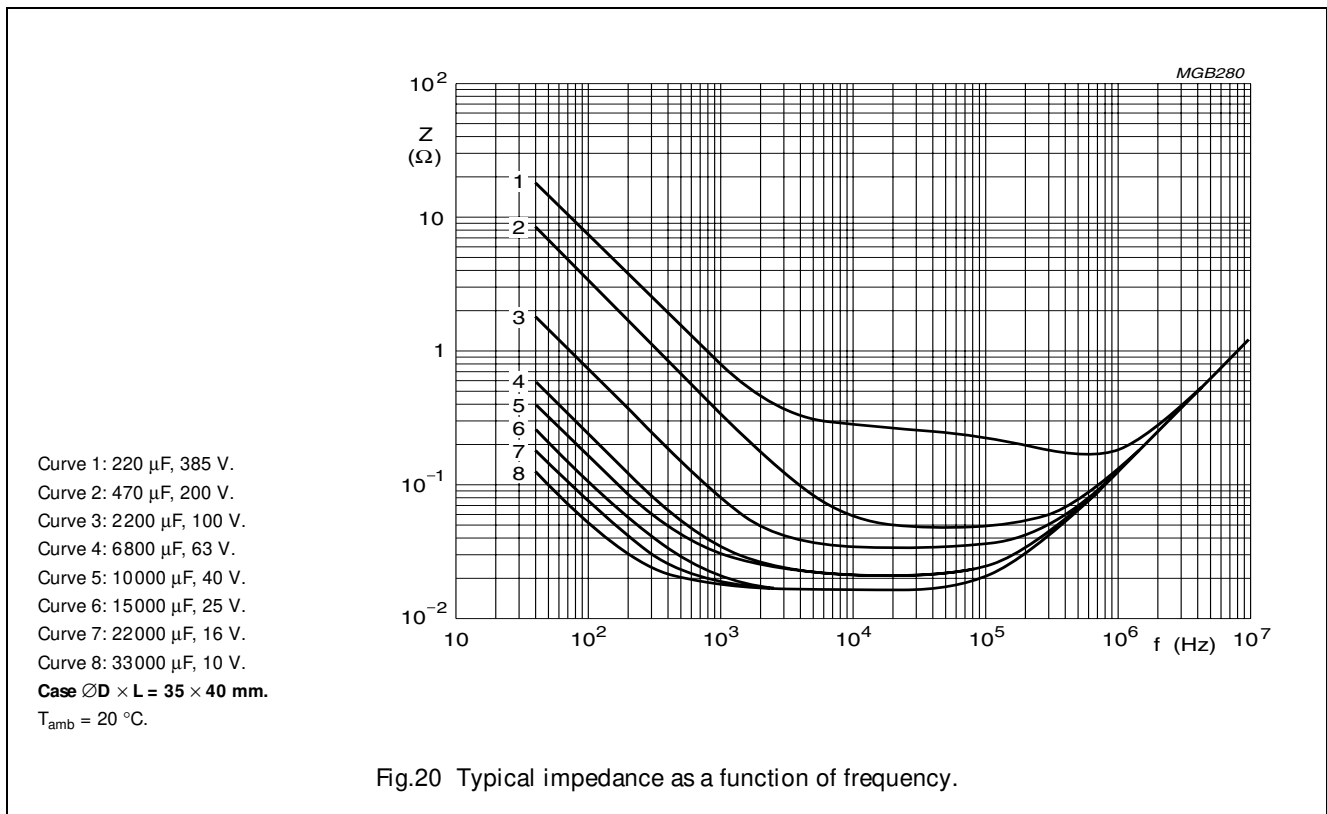
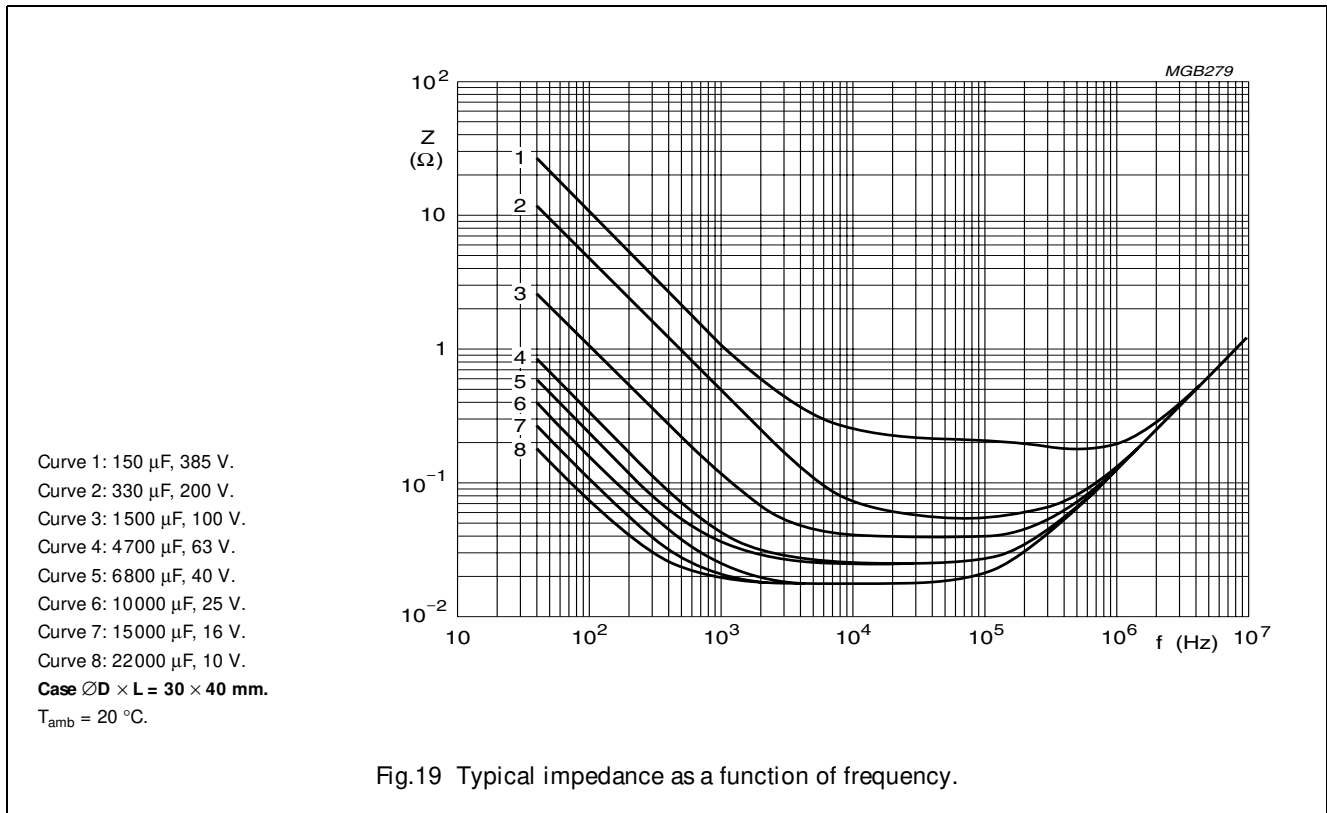

Fig.18 Typical impedance as a function of frequency.

Aluminum electrolytic capacitors
Power Economic Printed Wiring

05 1/053 PEG-PW



Aluminum electrolytic capacitors
Power Economic Printed Wiring

05 1/053 PEG-PW

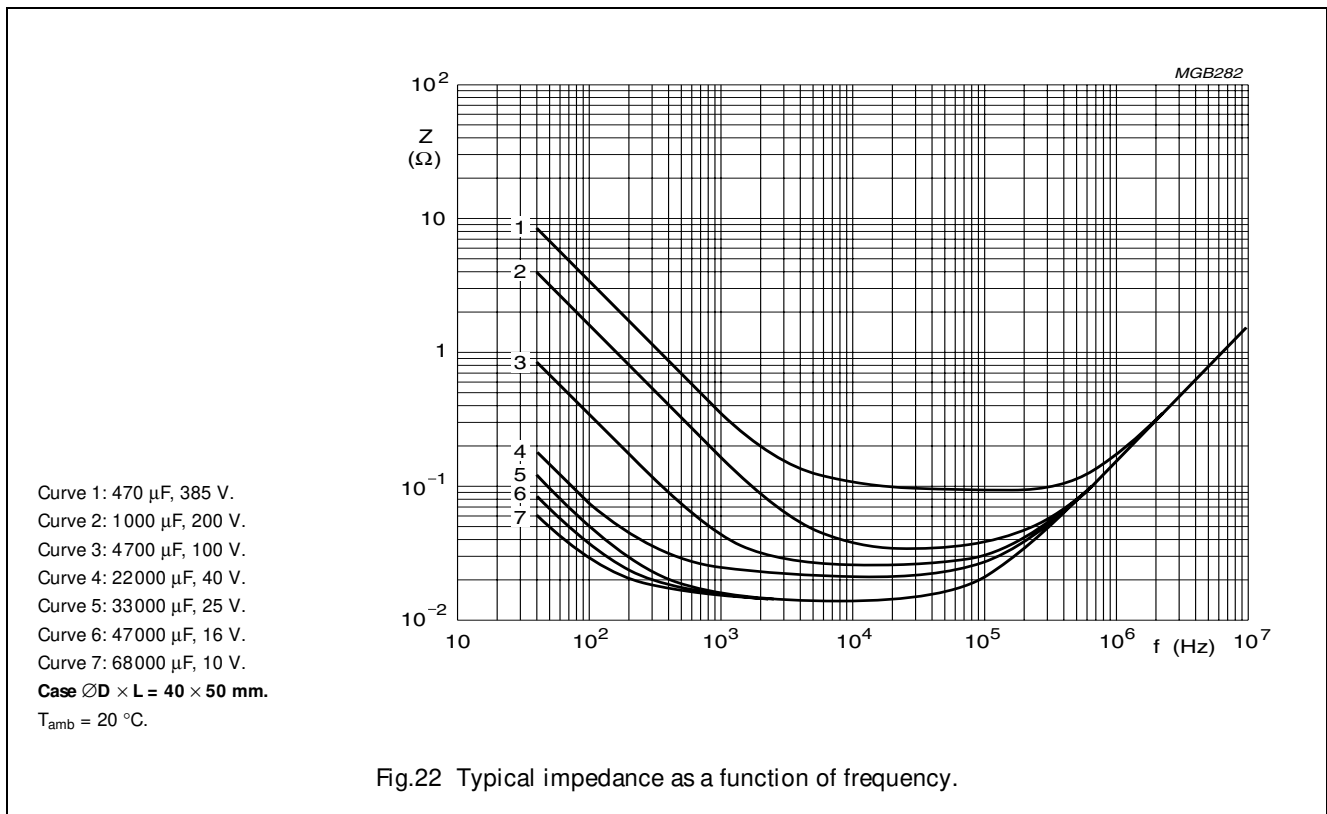
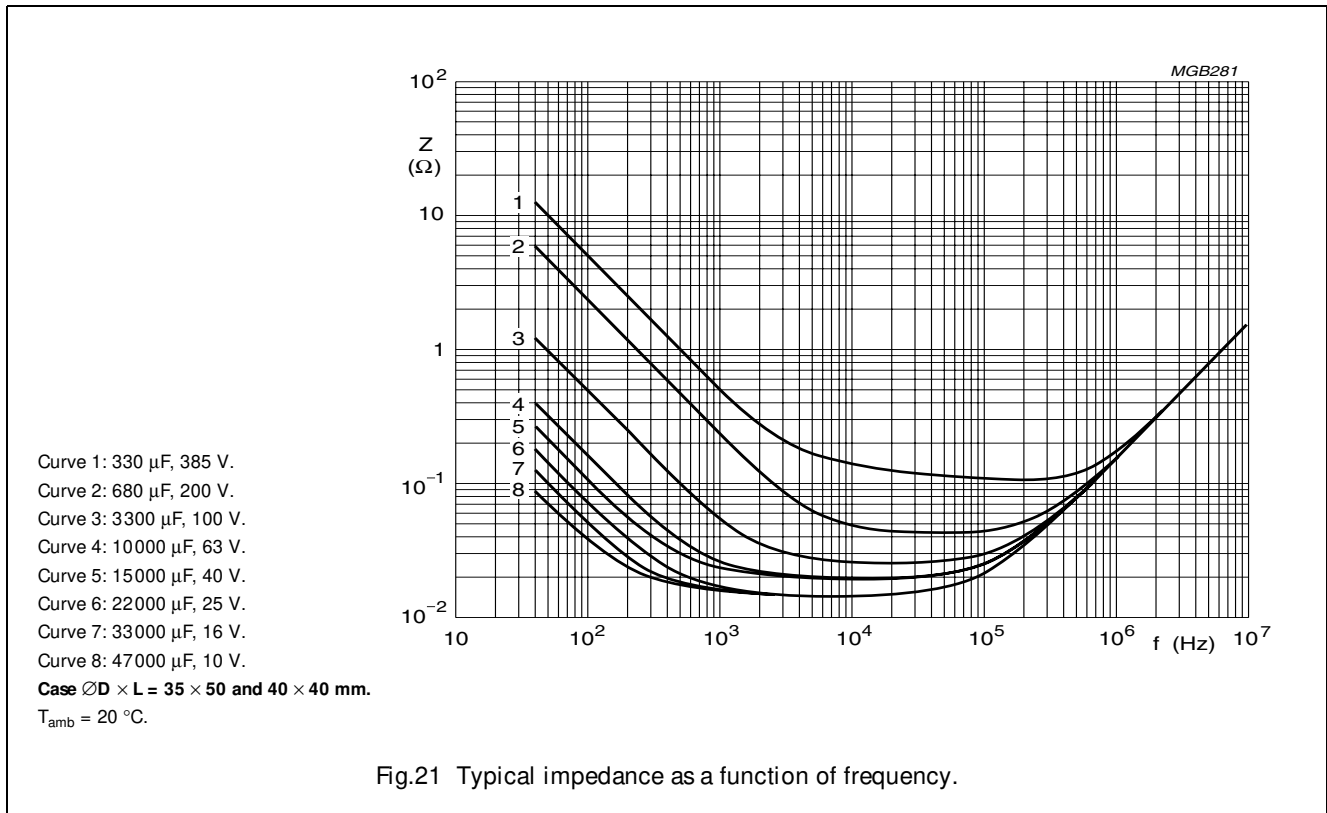

Aluminum electrolytic capacitors
Power Economic Printed Wiring

05 1/053 PEG-PW

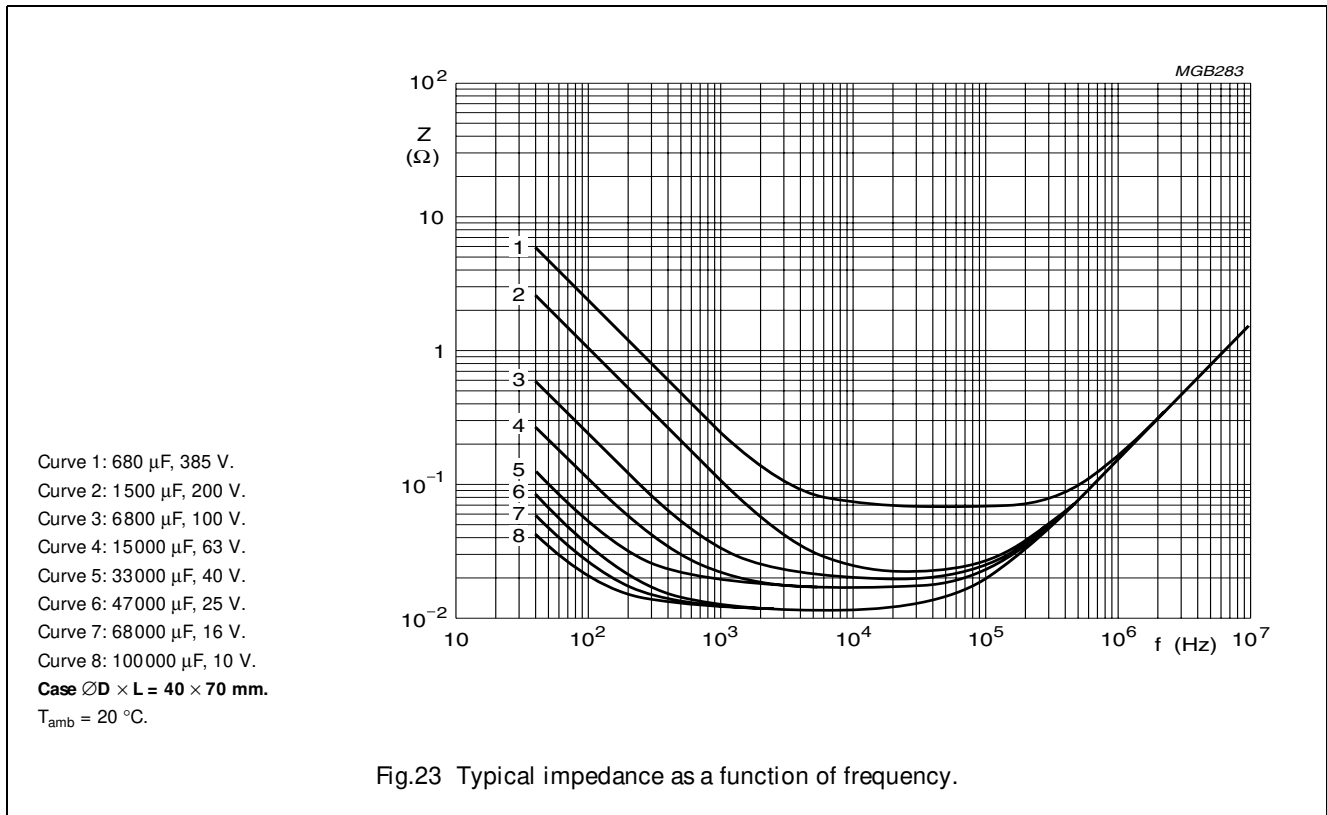

Fig.23 Typical impedance as a function of frequency.

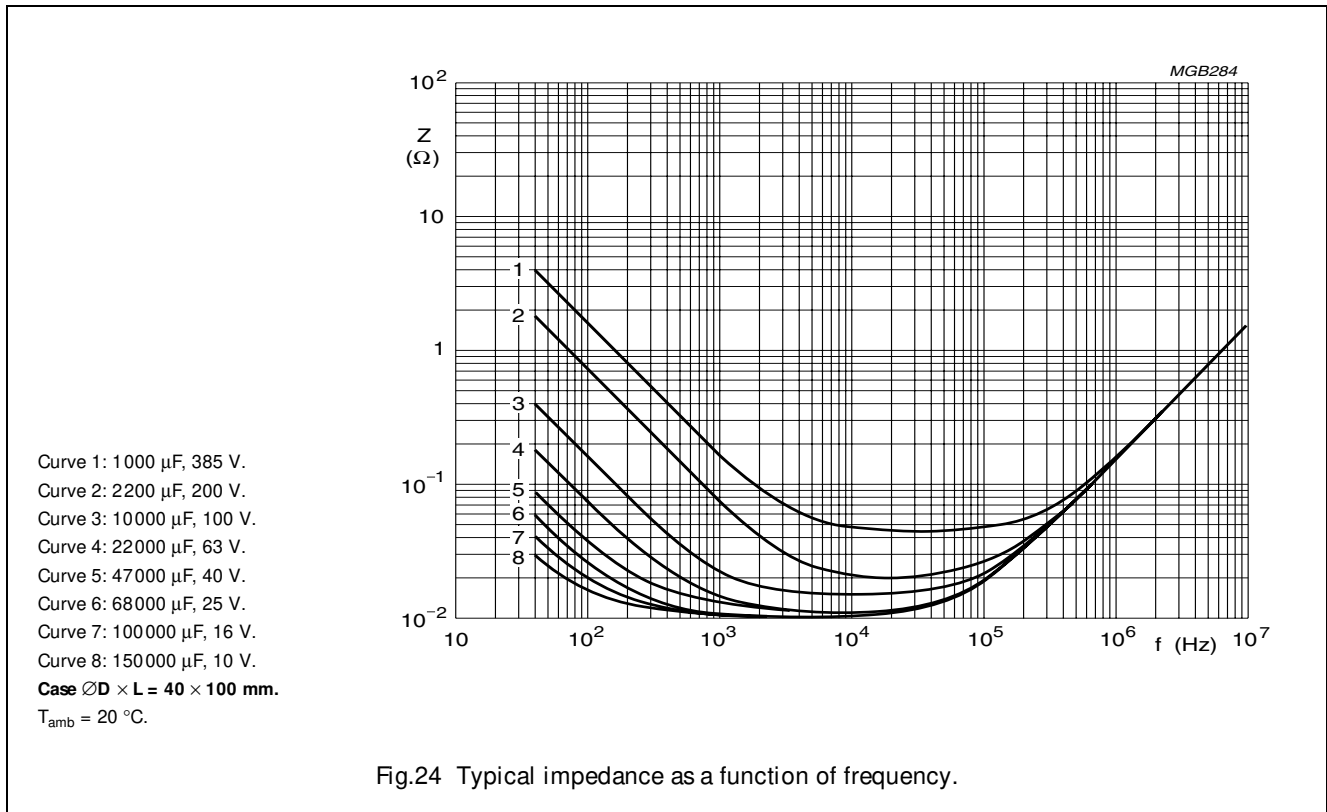

Fig.24 Typical impedance as a function of frequency.

Aluminum electrolytic capacitors
Power Economic Printed Wiring

05 1/0 53 PEG-PW

RIPPLE CURRENT AND USEFUL LIFE

Table 4 Multiplier of ripple current (I_R) as a function of frequency

FREQUENCY (Hz)	I_R MULTIPLIER
50	0.83
100	1.00
200	1.10
400	1.15
1000	1.19
≥ 2000	1.20

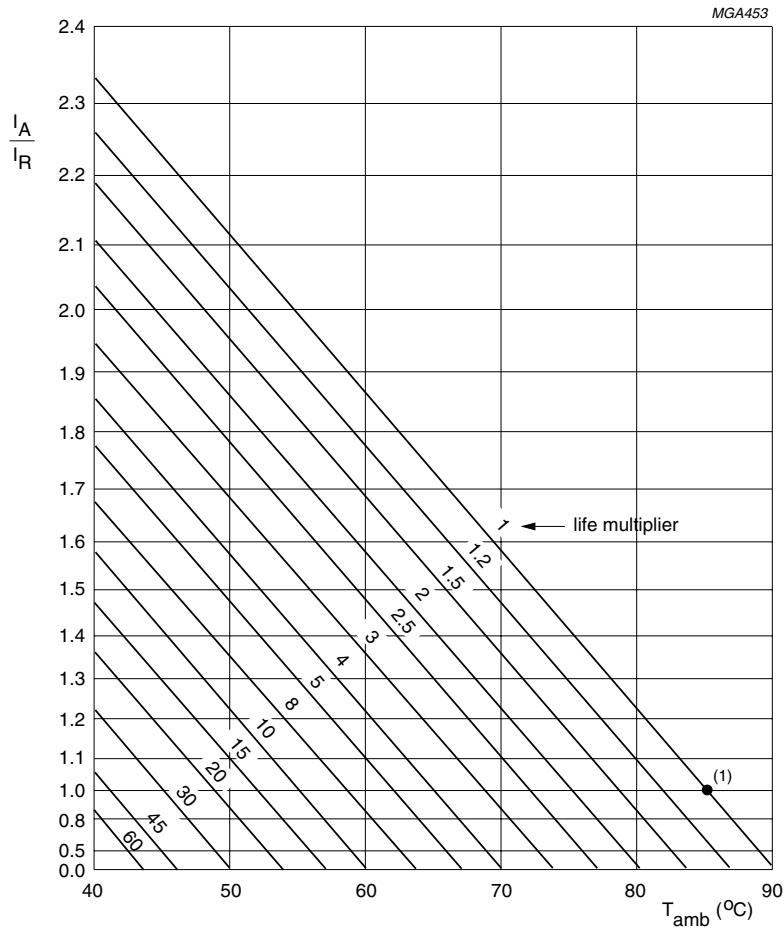

I_A = actual ripple current at 100 Hz.
 I_R = rated ripple current at 100 Hz and 85 °C.
 (1) Useful life at 85 °C and I_R applied: 12000 hours.

Fig.25 Multiplier of useful life as a function of ambient temperature and ripple current load.

Aluminum electrolytic capacitors

Power Economic Printed Wiring

05 1/0 53 PEG-PW

SPECIFIC TESTS AND REQUIREMENTS

General tests and requirements are specified in data handbook BC01, section "Tests and Requirements".

Table 5 Test procedures and requirements

TEST		PROCEDURE (quick reference)	REQUIREMENTS
NAME OF TEST	REFERENCE		
Endurance	IEC 60384-4/ EN130300 subclause 4.13	$T_{amb} = 85\text{ °C}$; U_R applied; 5000 hours	$U_R \leq 100\text{ V}$; $\Delta C/C: \pm 15\%$ $U_R > 100\text{ V}$; $\Delta C/C: \pm 10\%$ $ESR \leq 1.3 \times \text{spec. limit}$ $Z \leq 2 \times \text{spec. limit}$ $I_{L5} \leq \text{spec. limit}$
Useful life	CECC 30301 subclause 1.8.1	$T_{amb} = 85\text{ °C}$; U_R and I_R applied; 12000 hours	$U_R \leq 100\text{ V}$; $\Delta C/C: \pm 45\%$ $U_R > 100\text{ V}$; $\Delta C/C: \pm 30\%$ $ESR \leq 3 \times \text{spec. limit}$ $Z \leq 3 \times \text{spec. limit}$ $I_{L5} \leq \text{spec. limit}$ no short or open circuit, no visible damage total failure percentage: $U_R \leq 100\text{ V}: \leq 1\%$; $U_R > 100\text{ V}: \leq 3\%$
Shelf life (storage at high temperature)	IEC 60384-4/ EN130300 subclause 4.17	$T_{amb} = 85\text{ °C}$; no voltage applied; 500 hours after test: U_R to be applied for 30 minutes, 24 to 48 hours before measurement	$\Delta C/C: \pm 10\%$ $ESR \leq 1.2 \times \text{spec. limit}$ $I_{L5} \leq 2 \times \text{spec. limit}$