



Precise Metal-brush Motor

WEIGHT: 22g(APPROX)

Performance Range

Voltage: 1.5-24VDC

Speed: 1500-6000rpm

Torque: 2-20g.cm

Typical Applications

CD and DVD Player

Air Freshener dispenser

Massager

MODEL	VOLTAGE		NO LOAD		AT MAXIMUM EFFICIENCY			AT STALL	
	WORKING RANGE	NOMINAL	SPEED	CURRENT	SPEED	CURRENT	TORQUE	TORQUE	CURRENT
			rpm	A	rpm	A	g.cm	g.cm	A
ET-DCM2513R-1D390	2.8-7.0	3.9V CONSTANT	4400	0.021	3520	0.084	4.8	24	0.34
ET-DCM2513R-11440	0.7-4.5	2.0V CONSTANT	2200	0.018	1600	0.055	2.7	12	0.17
ET-DCM2513R-13300	1.5-4.5	2.0V CONSTANT	3300	0.025	2700	0.087	3.0	17	0.35
ET-DCM2513R-09550	1.0-6.0	3.0V CONSTANT	2900	0.010	2200	0.060	2.5	13	0.15

DIRECTION OF ROTATION

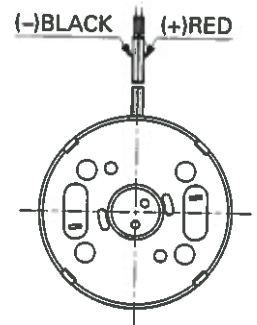
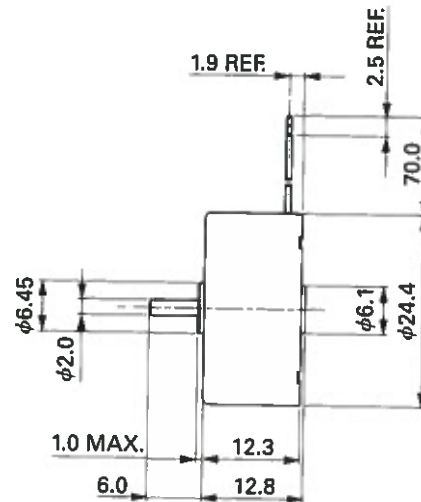
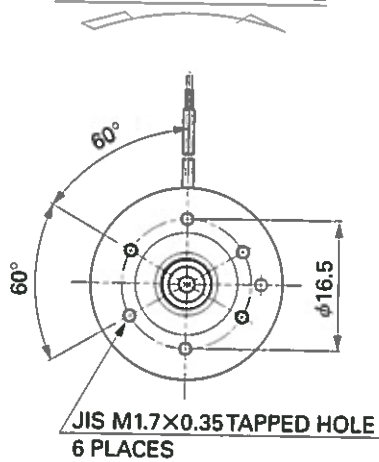

UNIT: MM

ET-DCM2513R-1D390

3.9V

