

VERY LOW DROP 5V REGULATOR WITH RESET

- PRECISE OUTPUT VOLTAGE ($5\text{ V} \pm 4\%$)
- VERY LOW DROPOUT VOLTAGE
- OUTPUT CURRENT IN EXCESS OF 500mA
- POWER-ON, POWER-OFF INFORMATION (RESET FUNCTION)
- HIGH NOISE IMMUNITY ON RESET DELAY CAPACITOR

DESCRIPTION

The L387A is a very low drop voltage regulator in a Pentawatt[®] package specially designed to provide stabilized 5V supplies in consumer and industrial applications. Thanks to its very low input/output voltage drop this device is very useful in battery powered equipment, reducing consumption and prolonging battery life. A reset output makes the L387A particularly suitable for microprocessor systems. This output provides a reset signal when power is applied (after an external programmable delay) and goes low when

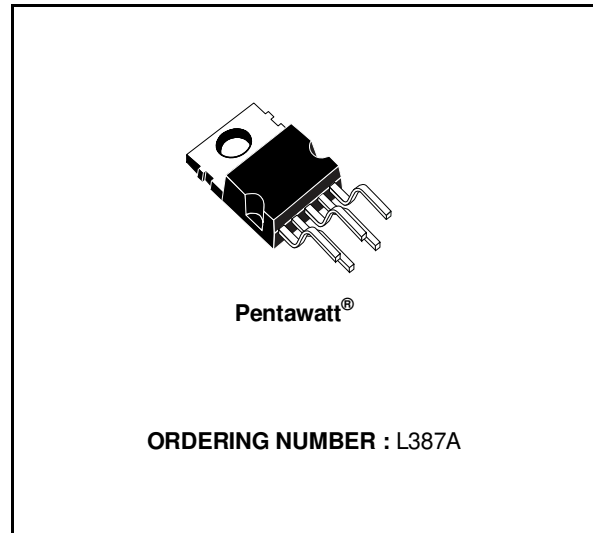

power is removed, inhibiting the microprocessor. An hysteresis on reset delay capacitor raises the immunity to the ground noise.

ABSOLUTE MAXIMUM RATINGS

Symbol	Parameter	Value	Unit
V_i	D.C. Input Voltage	35	V
T_j, T_{stg}	Junction and Storage Temperature Range	-55 to 150	°C

APPLICATION CIRCUIT

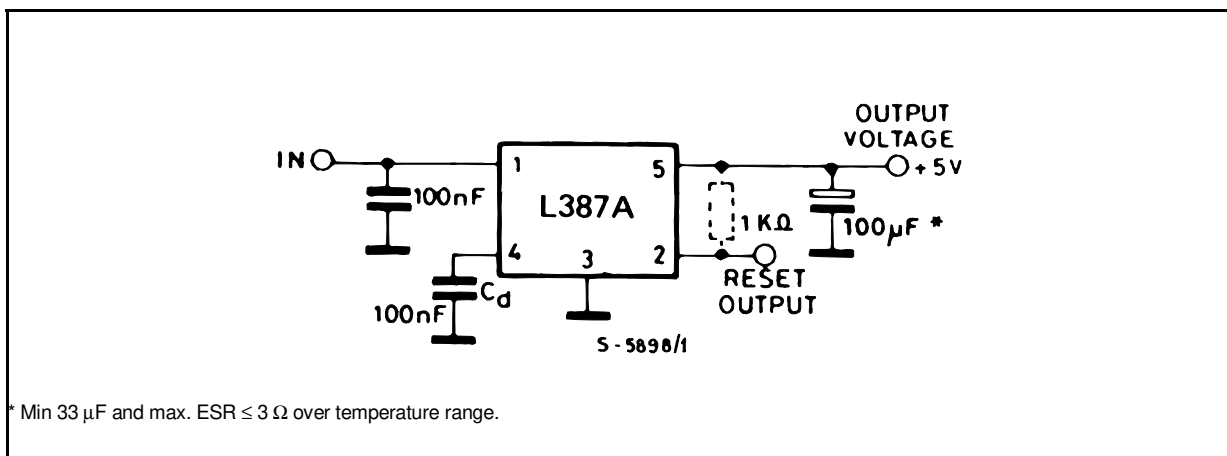

L387A

PIN CONNECTION (Top views)

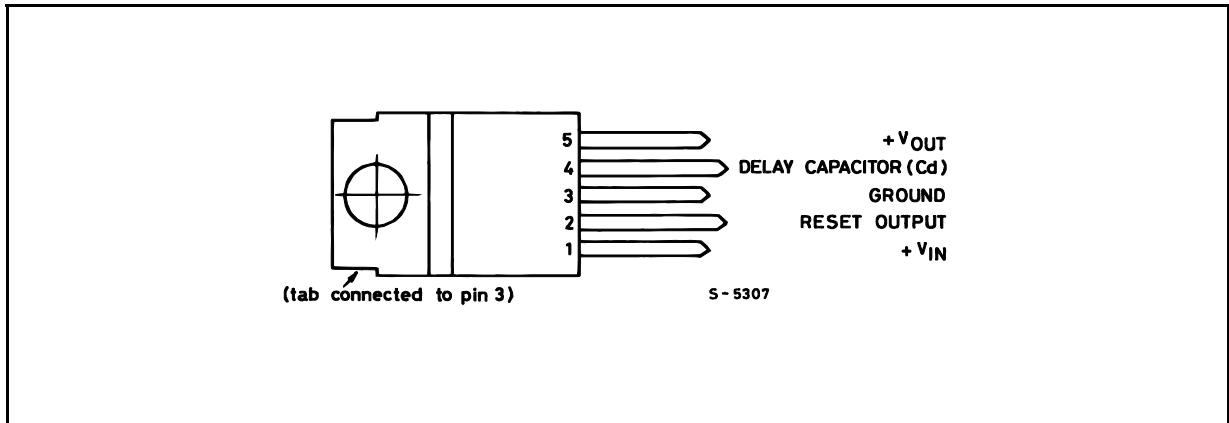

BLOCK DIAGRAM

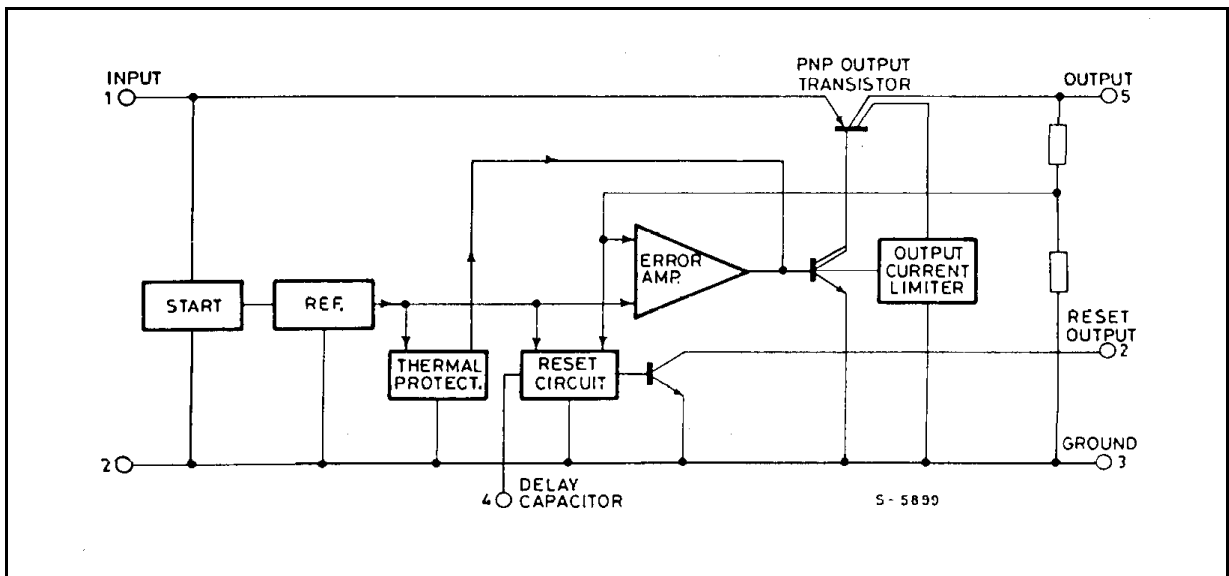

THERMAL DATA

R _{th j-case}	Thermal Resistance Junction-case	Max	4	°C/W
------------------------	----------------------------------	-----	---	------

ELECTRICAL CHARACTERISTICS (refer to the test circuit, $V_i = 14.4\text{ V}$, $T_j = 25\text{ °C}$, $C_o = 100\text{ }\mu\text{F}$; unless otherwise specified)

Symbol	Parameter	Test Conditions	Min.	Typ.	Max.	Unit
V_o	Output Voltage	$I_o = 5\text{ mA to } 500\text{ mA}$ $T_j = 25\text{ °C}$	4.80	5.00	5.20	V
		$-40 \leq T_j \leq 125\text{ °C}$	4.75	5.00	5.25	V
V_i	Operating Input Voltage	(*), Over Full T Range (-40 to 125 °C) (see note **)			26	V
ΔV_o	Line Regulation	$V_i = 6\text{ V to } 26\text{ V}$ $I_o = 5\text{ mA}$		5	50	mV
ΔV_o	Load Regulation	$I_o = 5\text{ mA to } 500\text{ mA}$		15	60	mV
$V_i - V_o$	Dropout Voltage	$V_o = V_{O\text{ NOM}} - 100\text{ mV}$				
		$I_o = 350\text{ mA}$		0.40	0.65	V
		$I_o = 500\text{ mA}$		0.60	0.8	V
I_q	Quiescent Current	$I_o = 0\text{ mA}$		5	15	mA
		$I_o = 150\text{ mA}$		20	35	mA
		$I_o = 350\text{ mA}$		60	100	mA
		$I_o = 500\text{ mA}$		100	160	mA
		$V_i = 6.2\text{ V}$ $I_o = 500\text{ mA}$		160	180	mA
$\frac{\Delta V_o}{\Delta T}$	Temperature Output Voltage Drift			-0.5		mV/°C
SVR	Supply Voltage Rejection	$I_o = 350\text{ mA}$ $f = 120\text{ Hz}$ $C_o = 100\text{ }\mu\text{F}$ $V_i = 12\text{ V} \pm 5\text{ V}_{pp}$			60	
I_{SC}	Output Short Circuit Current			1.2	1.6	A
V_R	Reset Output Voltage	$I_R = 3\text{ mA}$ $1 < V_o < 4.70\text{ V}$			0.5	V
		$I_R = 16\text{ mA}$ $1.5 < V_o < 4.75\text{ V}$ Over Full T ($-40\text{ °C} \leq T_j \leq 125\text{ °C}$)			0.8	V
I_R	Reset Output Leakage Current	V_o in Regulation $V_R = 5\text{ V}$ Over Full T Range			50	μA
t_d	Delay Time for Reset Output	$C_d = 100\text{ nF}$ Over Full T Range		25		ms
$V_{RT\text{ (off)}}$		V_o @ Reset out H to L Transition, Over Full T Range	4.75	$V_o - 0.15$		V
I_{C4}	Charging Current (current generator)	$V_4 = 3\text{ V}$	10	20	30	μA
$V_{RT\text{ (on)}}$	Power on V_o Threshold	V_o @ Reset out L to H Transition, Over Full T Range		$V_{RT\text{ (off)}} + 0.05\text{ V}$	$V_o - 0.04\text{ V}$	V
V_4	Comparator Threshold (pin 4)	V_4 @ Reset out H to L Transition	3.2		3.9	V
		V_4 @ Reset out L to H Transition	3.7		4.3	V
V_H	Hysteresis Voltage	Over Full T Range		450		mV

(*) For a DC voltage $26 < V_i < 37\text{ V}$ the device is not operating.

(**) Design limits are guaranteed (but not 100 % production tested) over the indicated temperature and supply voltage ranges. These limits are not used to calculate outgoing quality levels.

Figure 1 : Dropout Voltage vs. Output Current.

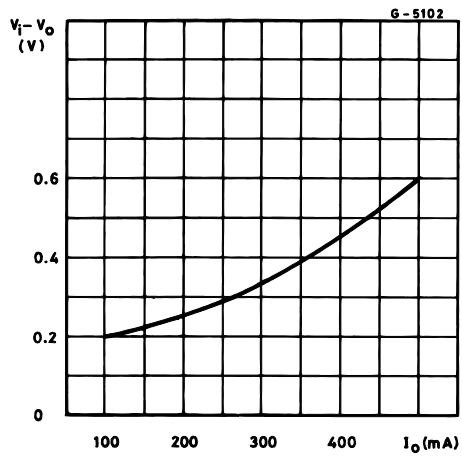

Figure 2 : Quiescent Current vs. Output Current.

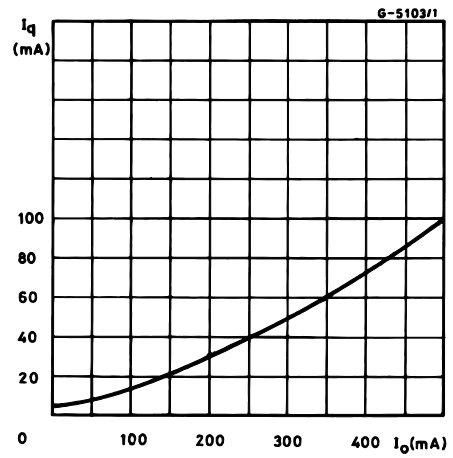
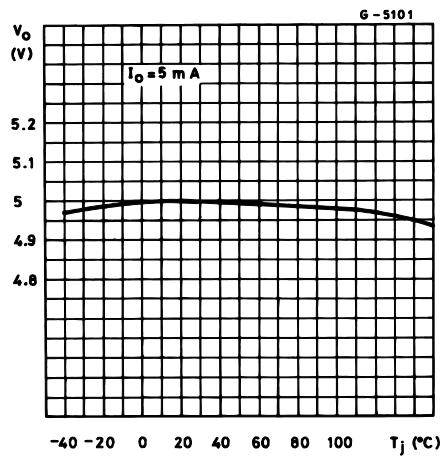

Figure 3 : Output Voltage vs. Temperature.



DIM.	mm			inch		
	MIN.	TYP.	MAX.	MIN.	TYP.	MAX.
A			4.8			0.189
C			1.37			0.054
D	2.4		2.8	0.094		0.110
D1	1.2		1.35	0.047		0.053
E	0.35		0.55	0.014		0.022
E1	0.76		1.19	0.030		0.047
F	0.8		1.05	0.031		0.041
F1	1.0		1.4	0.039		0.055
G	3.2	3.4	3.6	0.126	0.134	0.142
G1	6.6	6.8	7.0	0.260	0.268	0.276
H2			10.4			0.409
H3	10.05		10.4	0.396		0.409
L	17.55	17.85	18.15	0.691	0.703	0.715
L1	15.55	15.75	15.95	0.612	0.620	0.628
L2	21.2	21.4	21.6	0.831	0.843	0.850
L3	22.3	22.5	22.7	0.878	0.886	0.894
L4			1.29			0.051
L5	2.6		3.0	0.102		0.118
L6	15.1		15.8	0.594		0.622
L7	6.0		6.6	0.236		0.260
L9	2.1		2.7	0.008		0.106
L10	4.3		4.8	0.17		0.189
M	4.23	4.5	4.75	0.167	0.178	0.187
M1	3.75	4.0	4.25	0.148	0.157	0.167
V4	40° (typ.)					
V5	90° (typ.)					
Dia	3.65		3.85	0.144		0.152

OUTLINE AND MECHANICAL DATA

Weight: 2.00gr

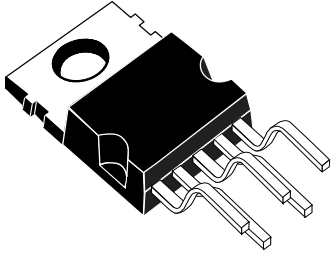

Pentawatt V

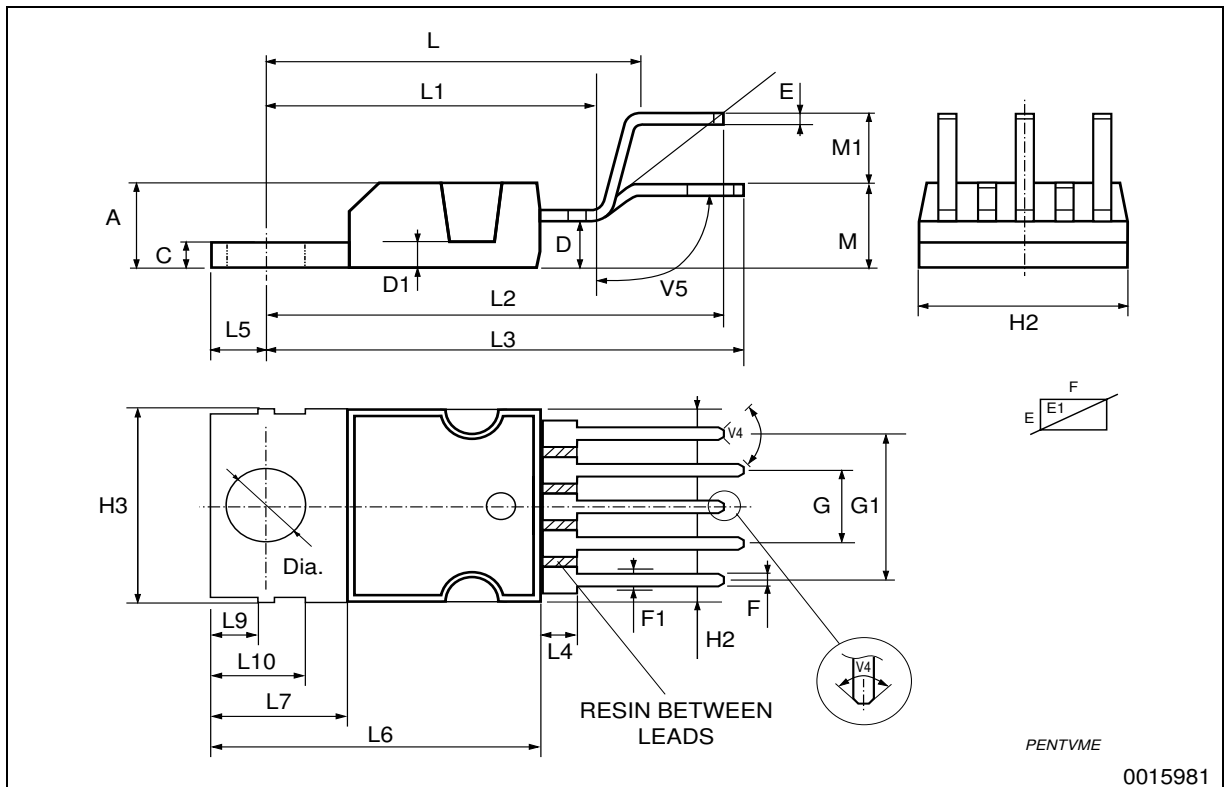

Information furnished is believed to be accurate and reliable. However, STMicroelectronics assumes no responsibility for the consequences of use of such information nor for any infringement of patents or other rights of third parties which may result from its use. No license is granted by implication or otherwise under any patent or patent rights of STMicroelectronics. Specification mentioned in this publication are subject to change without notice. This publication supersedes and replaces all information previously supplied. STMicroelectronics products are not authorized for use as critical components in life support devices or systems without express written approval of STMicroelectronics.

The ST logo is a registered trademark of STMicroelectronics
© 2003 STMicroelectronics – Printed in Italy – All Rights Reserved
STMicroelectronics GROUP OF COMPANIES

Australia - Brazil - Canada - China - Finland - France - Germany - Hong Kong - India - Israel - Italy - Japan - Malaysia - Malta - Morocco - Singapore - Spain - Sweden - Switzerland - United Kingdom - United States.

<http://www.st.com>