

Arduino® Nano RP2040 Connect

Description

The feature packed **Arduino® Nano RP2040 Connect** brings the new **Raspberry Pi RP2040** microcontroller to the Nano form factor. Make the most of the dual core **32-bit Arm® Cortex®-M0+** to make Internet of Things projects with Bluetooth and WiFi connectivity thanks to the **U-blox® Nina W102** module. Dive into real-world projects with the onboard accelerometer, gyroscope, RGB LED and microphone. The external The **Arduino® Nano RP2040 Connect** is pin-compatible with the Nano form factor to develop robust solutions with minimal effort!



Target Areas

Internet of Things (IoT), machine learning, prototyping,

Features

- **Raspberry Pi RP2040** Microcontroller
 - 133MHz 32bit Dual Core Arm® Cortex®-M0+
 - 264kB on-chip SRAM
 - Direct Memory Access (DMA) controller
 - Support for up to 16MB of off-chip Flash memory via dedicated QSPI bus
 - USB 1.1 controller and PHY, with host and device support
 - 8 PIO state machines
 - Programmable IO (PIO) for extended peripheral support
 - 4 channel ADC with internal temperature sensor, 0.5 MSa/s, 12-bit conversion
 - SWD Debugging
 - 2 on-chip PLLs to generate USB and core clock
 - 40nm process node
 - Multiple low power mode support
 - USB 1.1 Host/Device
 - Internal Voltage Regulator to supply the core voltage
 - Advanced High-performance Bus (AHB)/Advanced Peripheral Bus (APB)
- **U-blox® Nina W102** WiFi/Bluetooth Module
 - 240MHz 32bit Dual Core Xtensa LX6
 - 520kB on-chip SRAM
 - 448 Kbyte ROM for booting and core functions
 - 16 Mbit FLASH for code storage including hardware encryption to protect programs and data
 - 1 kbit EFUSE (non-erasable memory) for MAC addresses, module configuration, Flash-Encryption, and Chip-ID
 - IEEE 802.11b/g/n single-band 2.4 GHz WiFi operation
 - Bluetooth 4.2
 - Integrated Planar Inverted-F Antenna (PIFA)
 - 4x 12-bit ADC
 - 3x I2C, SDIO, CAN, QSPI
- **Memory**
 - AT25SF128A 16MB NOR Flash
 - QSPI data transfer rate up to 532Mbps
 - 100K program/erase cycles



- **ST LSM6DSOXTR** 6-axis IMU
 - 3D Gyroscope
 - $\pm 2/\pm 4/\pm 8/\pm 16$ g full scale
 - 3D Accelerometer
 - $\pm 125/\pm 250/\pm 500/\pm 1000/\pm 2000$ dps full scale
 - Advanced pedometer, step detector and step counter
 - Significant Motion Detection, Tilt detection
 - Standard interrupts: free-fall, wakeup, 6D/4D orientation, click and double-click
 - Programmable finite state machine: accelerometer, gyroscope and external sensors
 - Machine Learning Core
 - Embedded temperature sensor
- **ST MP34DT06JTR** MEMS Microphone
 - AOP = 122.5 dB SPL
 - 64 dB signal-to-noise ratio
 - Omnidirectional sensitivity
 - -26 dBFS \pm 1 dB sensitivity
- **RGB LED**
 - Common Anode
 - Connected to U-blox® Nina W102 GPIO
- **Microchip® ATECC608A** Crypto
 - Cryptographic Co-Processor with Secure Hardware-Based Key Storage
 - I2C, SWI
 - Hardware Support for Symmetric Algorithms:
 - SHA-256 & HMAC Hash including off-chip context save/restore
 - AES-128: Encrypt/Decrypt, Galois Field Multiply for GCM
 - Internal High-Quality NIST SP 800-90A/B/C Random Number Generator (RNG)
 - Secure Boot Support:
 - Full ECDSA code signature validation, optional stored digest/signature
 - Optional communication key disablement prior to secure boot
 - Encryption/Authentication for messages to prevent on-board attacks
- **I/O**
 - 14x Digital Pin
 - 8x Analog Pin
 - Micro USB
 - UART, SPI, I2C Support
- **Power**



- **Safety Information**

- Class A



Contents

1 Application examples	7
2 Accessories	7
3 Related products	7
4 Recommended operating conditions	7
5 Power consumption	8
6 Block Diagram	8
7 Board Topology	9
7.1 Front View	9
7.2 Back View	10
8 Processor	11
9 WiFi/Bluetooth connectivity	12
10 6-axis IMU	12
11 External memory	12
12 Cryptography	12
13 Microphone	12
14 RGB LED	13
15 Power Tree	13
16 Board Operation	14
16.1 Getting started - IDE	14
16.2 Getting started - Arduino Web Editor	14
16.3 Getting started - Arduino IoT Cloud	14
16.4 Sample Sketches	14
16.5 Online resources	14
16.6 Board Recovery	15
17 J1 Micro USB	15
18 JP1	15
19 JP2	16
20 RP2040 SWD Pad	16
21 Nina W102 SWD Pad	16
22 Declaration of Conformity CE DoC (EU)	17
23 Declaration of Conformity to EU RoHS & REACH 211 01/19/2021	1
24 Conflict Minerals Declaration	18
25 FCC Caution	18



26 Company information	20
27 Reference Documentation	20
28 Revision History	20



The board

1 Application examples

The Arduino® Nano RP2040 Connect can be adapted to a wide range of use cases thanks to the powerful microprocessor, range of onboard sensors and Nano form factor. Possible applications include:

- **Edge Computing:** Make use of the fast and high RAM microprocessor to run TinyML for anomaly detection, cough detection, gesture analysis and more.
- **Wearable Devices:** The small Nano footprint provides the possibility of providing machine learning to a range of wearble devices including sports trackers and VR controllers.
- **Voice assistant:** The Arduino® RP2040 Connect includes an omnidirectional microphone that can act as your personal digital assistant and enable voice control for your projects.

2 Accessories

- Micro USB cable
- 15-pin 2.54mm male headers
- 15-pin 2.54mm stackable headers

3 Related products

- Gravity: Nano I/O Shield
- Arduino Nano Motor Carrier

Ratings

4 Recommended operating conditions



Symbol	Description	Min	Typ	Max	Unit
V_{IN}	Input voltage from VIN pad	4	5	22	V
V_{USB}	Input voltage from USB connector	4.75	5	5.25	V
V_{3V3}	3.3V output to user application	3.25	3.3	3.35	V
I_{3V3}	3.3V output current (including onboard IC)	-	-	800	mA
V_{IH}	Input high-level voltage	2.31	-	3.3	V
V_{IL}	Input low-level voltage	0	-	0.99	V
$I_{OH Max}$	Current at VDD-0.4 V, output set high			8	mA
$I_{OL Max}$	Current at VSS+0.4 V, output set low			8	mA
V_{OH}	Output high voltage, 8 mA	2.7	-	3.3	V
V_{OL}	Output low voltage, 8 mA	0	-	0.4	V
T_{OP}	Operating Temperature	-20	-	80	°C

5 Power consumption

Symbol	Description	Min	Typ	Max	Unit
P_{BL}	Power consumption with busy loop		TBC		mW
P_{LP}	Power consumption in low power mode		TBC		mW
P_{MAX}	Maximum Power Consumption		TBC		mW

Functional overview

6 Block Diagram

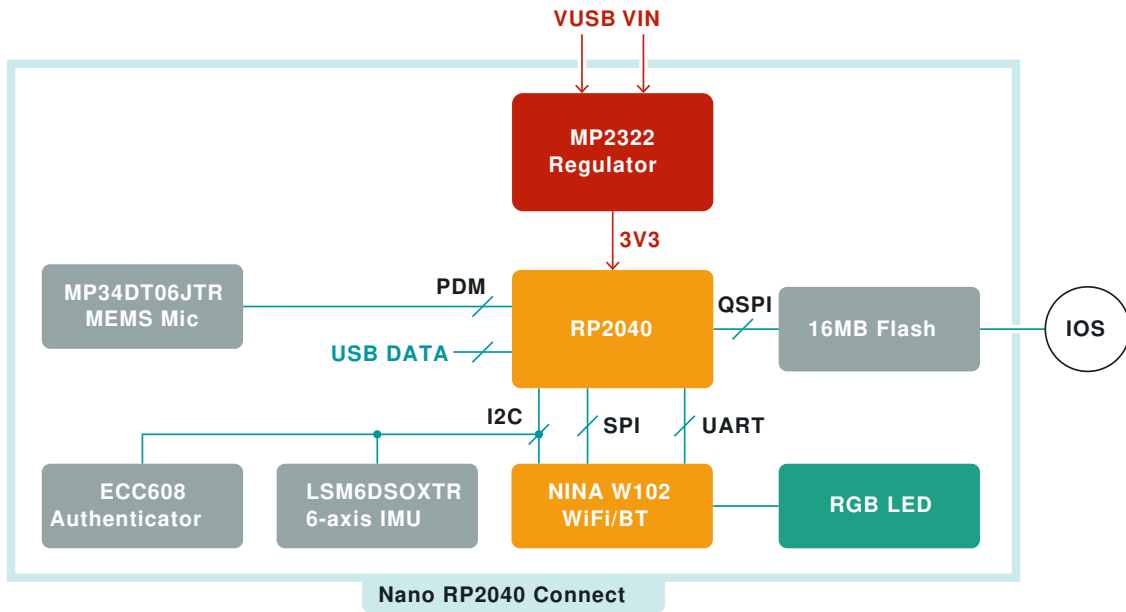

- | | |
|--|--|
| Power | Microcontroller |
| LED | Data Communication |
| Internal Parts | Software |

Block Diagram of Arduino Nano RP2040 Connect

7 Board Topology

7.1 Front View

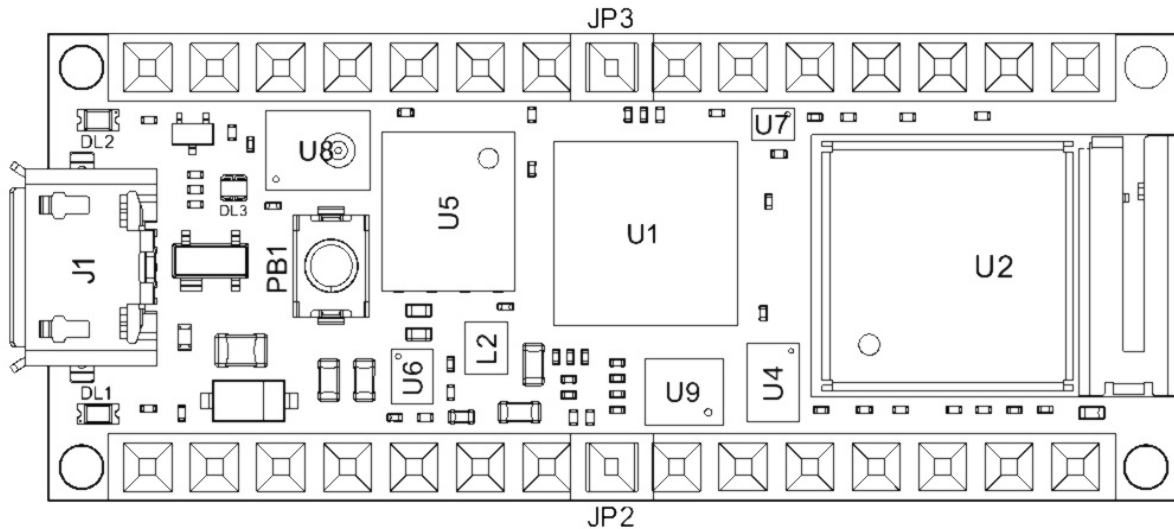

Front View of Arduino Nano RP2040 Connect Topology

Ref.	Description	Ref.	Description
U1	Raspberry Pi RP2040 Microcontroller	U2	Ublox NINA-W102-00B WiFi/Bluetooth Module
U3	N/A	U4	ATECC608A-MAHDA-T Crypto IC
U5	AT25SF128A-MHB-T 16MB Flash IC	U6	MP2322GQH Step-Down Buck Regulator
U7	DSC6111HI2B-012.0000 MEMS Oscillator	U8	MP34DT06JTR MEMS Omnidirectional Microphone IC
U9	LSM6DSOXTR 6-axis IMU with Machine Learning Core	J1	Male Micro USB Connector
DL1	Green Power On LED	DL2	Builtin Orange LED
DL3	RGB Common Anode LED	PB1	Reset Button
JP2	Analog Pin + D13 Pins	JP3	Digital Pins

7.2 Back View

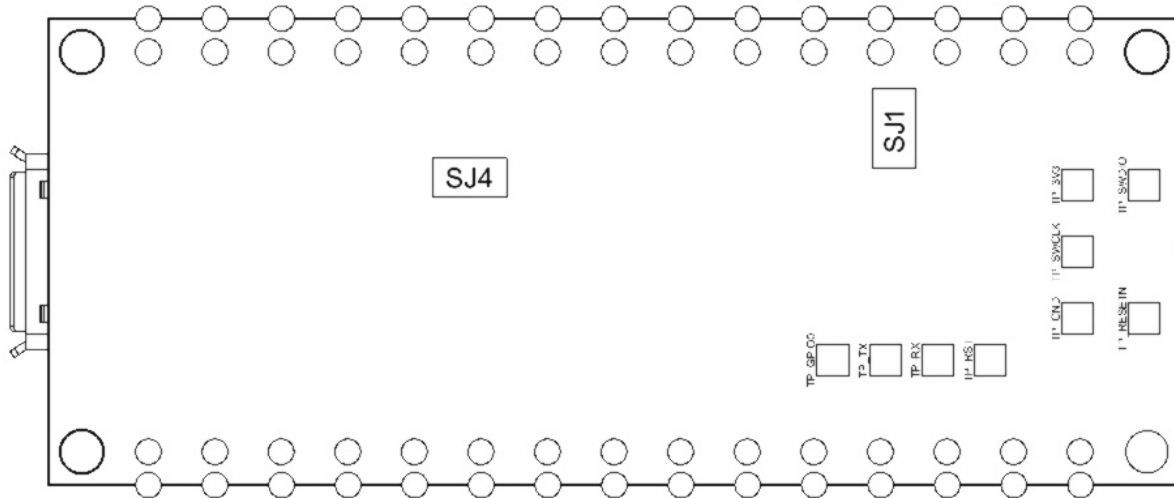

Back View of Arduino Nano RP2040 Connect Topology

Ref.	Description	Ref.	Description
SJ4	3.3V jumper (connected)	SJ1	VUSB jumper (disconnected)

8 Processor

The processor is based upon the new Raspberry Pi RP2040 silicon (U1). This microcontroller provides opportunities for low-power Internet of Things (IoT) development and embedded machine learning. Two symmetric Arm® Cortex®-M0+ clocked at 133MHz provide computation power for embedded machine learning and parallel processing with low power consumption. Six independent banks of 264 KB SRAM and 2MB are provided. Direct memory access provides fast interconnect between the processors and the memory that can be made inactive along with the core to enter a sleep state. Serial wire debug (SWD) is available from boot via the pads under the board. The RP2040 runs at 3.3V and has an internal voltage regulator providing 1.1V.

The RP2040 controls the peripherals and digital pins, as well as analog pins (A0-A3). The I2C connections on pins A4 (SDA) and A5 (SCL) are used for connecting to the onboards peripherals and are pulled up with a 4.7 kΩ resistor. SWD Clock line (SWCLK) and reset are also pulled up with a 4.7 kΩ resistor. An external MEMS oscillator (U7) running at 12MHz provides the clock pulse. Programmable IO helps to the implementation of arbitrary communication protocol with minimal burden on the main processing cores. A USB 1.1 device interface is implemented on the RP2040 for uploading code.



9 WiFi/Bluetooth connectivity

Wifi and Bluetooth connectivity is provided by the Nina W102 (U2) module. The RP2040 only has 4 analog pins, and the Nina is used to extend that to the full eight as is standard in the Arduino Nano form factor with another 4 12-bit analog inputs (A4-A7). Additionally, the common anode RGB LED is also controlled by the Nina W-102 module such that the LED is off when the digital state is HIGH and on when the digital state is LOW. The internal PCB antenna in the module eliminates the need for an external antenna. The Nina W102 module also includes a dual core Xtensa LX6 CPU that can also be programmed independantly of the RP2040 through the pads under the board using SWD.

10 6-axis IMU

It is possible to obtain 3D gyroscope and 3D accelerometer data from the LSM6DSOX 6-axis IMU (U9). In addition to providing such data, it is also possible to do machine learning on the IMU for gesture detection.

11 External memory

The RP2040 (U1) has access to an additional 16 MB of flash memory via a QSPI interface. The execute-in-place (XIP) feature of the RP2040 allows external flash memory to be addressed and accessed by the system as though it were internal memory, without first copying the code to internal memory.

12 Cryptography

The ATECC608A Cryptographic IC (U4) provides secure boot capabilities alongside SHA and AES-128 encryption/decryption support for security in Smart Home and Industrial IoT (IIoT) applications. Additionally, a random number generator is also available for use by the RP2040.

13 Microphone

The MP34DT06J microphone is connected via a PDM interface to the RP2040. The digital MEMS microphone is omnidirectional and operate via a capacitive sensing element with a high (64 dB) signal to noise ratio. The sensing element, capable of detecting acoustic waves, is manufactured using a specialized silicon micromachining process dedicated to produce audio sensors.



14 RGB LED

The RGB LED (DL3) is a common anode LED that is connected to the Nina W102 module. The LED are off when the digital state is HIGH and on when the digital state is LOW.

15 Power Tree

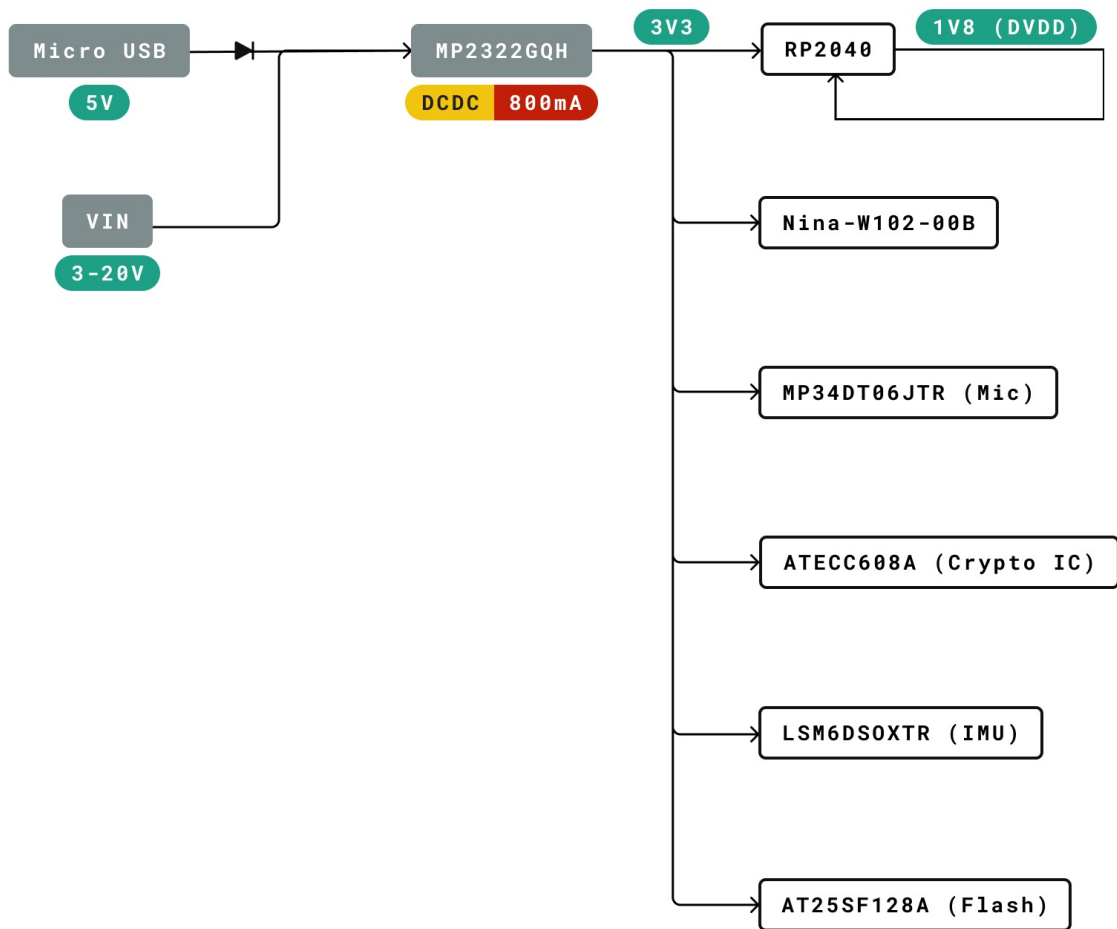

Legend:

- Component
- Power I/O
- Conversion Type
- Max Current
- Voltage Range

Power Tree of Arduino Nano RP2040 Connect Topology

The Arduino Nano RP2040 Connect can be powered by either the Micro USB port (J1) or alternatively via VIN on JP2. An onboard buck converter provides 3V3 to the RP2040



microcontroller and all other peripherals. Additionally, the RP2040 also has an internal 1V8 regulator.

16 Board Operation

16.1 Getting started - IDE

If you want to program your Arduino® Nano RP2040 Connect while offline you need to install the Arduino® Desktop IDE **[1]** To connect the Arduino® Edge control to your computer, you'll need a micro USB cable. This also provides power to the board, as indicated by the LED.

16.2 Getting started - Arduino Web Editor

All Arduino® boards, including this one, work out-of-the-box on the Arduino® Web Editor **[2]**, by just installing a simple plugin.

The Arduino® Web Editor is hosted online, therefore it will always be up-to-date with the latest features and support for all boards. Follow **[3]** to start coding on the browser and upload your sketches onto your board.

16.3 Getting started - Arduino IoT Cloud

All Arduino® IoT enabled products are supported on Arduino® IoT Cloud which allows you to Log, graph and analyze sensor data, trigger events, and automate your home or business.

16.4 Sample Sketches

Sample sketches for the Arduino® Nano RP2040 Connect can be found either in the “Examples” menu in the Arduino® IDE or in the “Documentation” section of the Arduino website **[4]**

16.5 Online resources

Now that you have gone through the basics of what you can do with the board you can explore the endless possibilities it provides by checking exciting projects on ProjectHub **[5]**, the Arduino® Library Reference **[6]** and the online store **[7]** where you will be able to complement your board with sensors, actuators and more.



16.6 Board Recovery

All Arduino boards have a built-in bootloader which allows flashing the board via USB. In case a sketch locks up the processor and the board is not reachable anymore via USB it is possible to enter bootloader mode by double-tapping the reset button right after power up.

Connector Pinouts

17 J1 Micro USB

Pin	Function	Type	Description
1	VBUS	Power	5V USB Power
2	D-	Differential	USB differential data -
3	D+	Differential	USB differential data +
4	ID	Digital	Unused
5	GND	Power	Ground

18 JP1

Pin	Function	Type	Description
1	TX1	Digital	UART TX / Digital Pin 1
2	RX0	Digital	UART RX / Digital Pin 0
3	RST	Digital	Reset
4	GND	Power	Ground
5	D2	Digital	Digital Pin 2
6	D3	Digital	Digital Pin 3
7	D4	Digital	Digital Pin 4
8	D5	Digital	Digital Pin 5
9	D6	Digital	Digital Pin 6
10	D7	Digital	Digital Pin 7
11	D8	Digital	Digital Pin 8
12	D9	Digital	Digital Pin 9
13	D10	Digital	Digital Pin 10
14	D11	Digital	Digital Pin 11
15	D12	Digital	Digital Pin 12



19 JP2

Pin	Function	Type	Description
1	D13	Digital	Digital Pin 13
2	3.3V	Power	3.3V Power
3	REF	Analog	NC
4	A0	Analog	Analog Pin 0
5	A1	Analog	Analog Pin 1
6	A2	Analog	Analog Pin 2
7	A3	Analog	Analog Pin 3
8	A4	Analog	Analog Pin 4
9	A5	Analog	Analog Pin 5
10	A6	Analog	Analog Pin 6
11	A7	Analog	Analog Pin 7
12	VUSB	Power	USB Input Voltage
13	REC	Digital	BOOTSEL
14	GND	Power	Ground
15	VIN	Power	Voltage Input

Note: The analog reference voltage is fixed at +3.3V. A0-A3 are connected to the RP2040's ADC. A4-A7 are connected to the Nina W102 ADC. Additionally, A4 and A5 are shared with the I2C bus of the RP2040 and are each pulled up with 4.7 KΩ resistors.

20 RP2040 SWD Pad

Pin	Function	Type	Description
1	SWDIO	Digital	SWD Data Line
2	GND	Digital	Ground
3	SWCLK	Digital	SWD Clock
4	+3V3	Digital	+3V3 Power Rail
5	TP_RESETN	Digital	Reset

21 Nina W102 SWD Pad

Pin	Function	Type	Description
1	TP_RST	Digital	Reset
2	TP_RX	Digital	Serial Rx
3	TP_TX	Digital	Serial Tx
4	TP_GPIO0	Digital	GPIO0



Mechanical Information

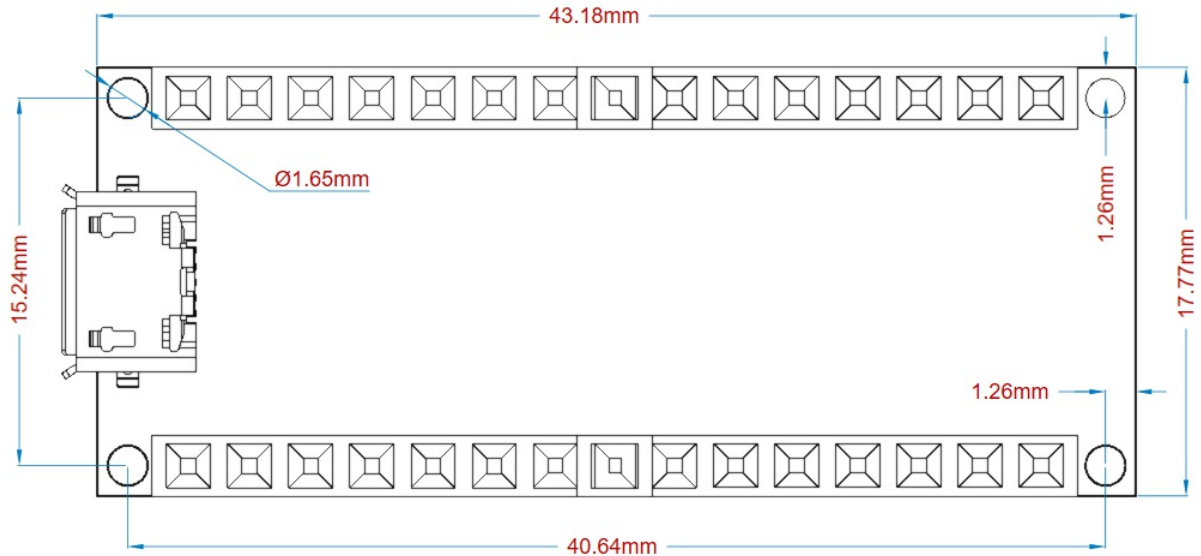

Power Tree of Arduino Nano RP2040 Connect Topology

Certifications

22 Declaration of Conformity CE DoC (EU)

We declare under our sole responsibility that the products above are in conformity with the essential requirements of the following EU Directives and therefore qualify for free movement within markets comprising the European Union (EU) and European Economic Area (EEA).

23 Declaration of Conformity to EU RoHS & REACH 211 01/19/2021

Arduino boards are in compliance with RoHS 2 Directive 2011/65/EU of the European Parliament and RoHS 3 Directive 2015/863/EU of the Council of 4 June 2015 on the restriction of the use of certain hazardous substances in electrical and electronic equipment.



Substance	Maximum Limit (ppm)
Lead (Pb)	1000
Cadmium (Cd)	100
Mercury (Hg)	1000
Hexavalent Chromium (Cr6+)	1000
Poly Brominated Biphenyls (PBB)	1000
Poly Brominated Diphenyl ethers (PBDE)	1000
Bis(2-Ethylhexyl} phthalate (DEHP)	1000
Benzyl butyl phthalate (BBP)	1000
Dibutyl phthalate (DBP)	1000
Diisobutyl phthalate (DIBP)	1000

Exemptions : No exemptions are claimed.

Arduino Boards are fully compliant with the related requirements of European Union Regulation (EC) 1907 /2006 concerning the Registration, Evaluation, Authorization and Restriction of Chemicals (REACH). We declare none of the SVHCs (<https://echa.europa.eu/web/guest/candidate-list-table>), the Candidate List of Substances of Very High Concern for authorization currently released by ECHA, is present in all products (and also package) in quantities totaling in a concentration equal or above 0.1%. To the best of our knowledge, we also declare that our products do not contain any of the substances listed on the "Authorization List" (Annex XIV of the REACH regulations) and Substances of Very High Concern (SVHC) in any significant amounts as specified by the Annex XVII of Candidate list published by ECHA (European Chemical Agency) 1907 /2006/EC.

24 Conflict Minerals Declaration

As a global supplier of electronic and electrical components, Arduino is aware of our obligations with regards to laws and regulations regarding Conflict Minerals, specifically the Dodd-Frank Wall Street Reform and Consumer Protection Act, Section 1502. Arduino does not directly source or process conflict minerals such as Tin, Tantalum, Tungsten, or Gold. Conflict minerals are contained in our products in the form of solder, or as a component in metal alloys. As part of our reasonable due diligence Arduino has contacted component suppliers within our supply chain to verify their continued compliance with the regulations. Based on the information received thus far we declare that our products contain Conflict Minerals sourced from conflict-free areas.

25 FCC Caution

Any Changes or modifications not expressly approved by the party responsible for compliance could void the user’s authority to operate the equipment.

This device complies with part 15 of the FCC Rules. Operation is subject to the following two conditions:



(1) This device may not cause harmful interference

(2) this device must accept any interference received, including interference that may cause undesired operation.

FCC RF Radiation Exposure Statement:

1. This Transmitter must not be co-located or operating in conjunction with any other antenna or transmitter.
2. This equipment complies with RF radiation exposure limits set forth for an uncontrolled environment.
3. This equipment should be installed and operated with minimum distance 20cm between the radiator & your body.

English: User manuals for licence-exempt radio apparatus shall contain the following or equivalent notice in a conspicuous location in the user manual or alternatively on the device or both. This device complies with Industry Canada licence-exempt RSS standard(s). Operation is subject to the following two conditions:

(1) this device may not cause interference

(2) this device must accept any interference, including interference that may cause undesired operation of the device.

French: Le présent appareil est conforme aux CNR d'Industrie Canada applicables aux appareils radio exempts de licence. L'exploitation est autorisée aux deux conditions suivantes :

(1) l' appareil nedoit pas produire de brouillage

(2) l'utilisateur de l'appareil doit accepter tout brouillage radioélectrique subi, même si le brouillage est susceptible d'en compromettre le fonctionnement.

IC SAR Warning:

English This equipment should be installed and operated with minimum distance 20 cm between the radiator and your body.

French: Lors de l' installation et de l' exploitation de ce dispositif, la distance entre le radiateur et le corps est d 'au moins 20 cm.

Important: The operating temperature of the EUT can't exceed 85°C and shouldn't be lower than -40°C.

Hereby, Arduino S.r.l. declares that this product is in compliance with essential requirements and other relevant provisions of Directive 201453/EU. This product is allowed to be used in all EU member states.



Frequency bands	Maximum output power (ERP)
2400-2483.5 Mhz	17 dBm

26 Company information

Company name	Arduino S.r.l.
Company Address	Via Ferruccio Pelli 14, 6900 Lugano, TI (Ticino), Switzerland

27 Reference Documentation

Ref	Link
Arduino IDE (Desktop)	https://www.arduino.cc/en/Main/Software
Arduino IDE (Cloud)	https://create.arduino.cc/editor
Cloud IDE Getting Started	https://create.arduino.cc/projecthub/Arduino_Genuino/getting-started-with-arduino-web-editor-4b3e4a
Arduino Website	https://www.arduino.cc/
Project Hub	https://create.arduino.cc/projecthub?by=part&part_id=11332&sort=trending
PDM (microphone) Library	https://www.arduino.cc/en/Reference/PDM
WiFinINA (WiFi, W102) Library	https://www.arduino.cc/en/Reference/WiFinINA
ArduinoBLE (Bluetooth, W-102) Library	https://www.arduino.cc/en/Reference/ArduinoBLE
IMU Library	https://www.arduino.cc/en/Reference/Arduino_LSM6DS3
Online Store	https://store.arduino.cc/

28 Revision History

Date	Revision	Changes
03/05/2020	1	First Release