



Jiangsu Everstar Electronics Co., Ltd.

Address:No.6 Xiangshan Rd, Tianmuhu Industry Park, Liyang City, Jiangsu Province, China

TEL: +86-519-87557772

FAX: +86-519-87557773

Http: www.everstarelect.com

DATA SHEET

ESL NO.. : ESS-2835WWDT-R80-WR

CUS NO. :

REV : A / 0

Producer: 张帆

Auditor: 沈云

Approver: 姜良

CUSTOMER'S APPROVAL : _____

DCC : _____

※ **Features:**

1. Package: 3.5*2.8*0.8mm (TOP view white LED)
2. Emitted Color: White
3. Mono-color type
4. Soldering methods: All SMT assembly methods
5. Compliant ROHS standard.

※ **Applications:**

1. LCD back light.
2. Mobile phones: LCD,
3. Status indicators: Consumer & industrial electronics.
4. General use.

※ **Package Outline Dimension:**

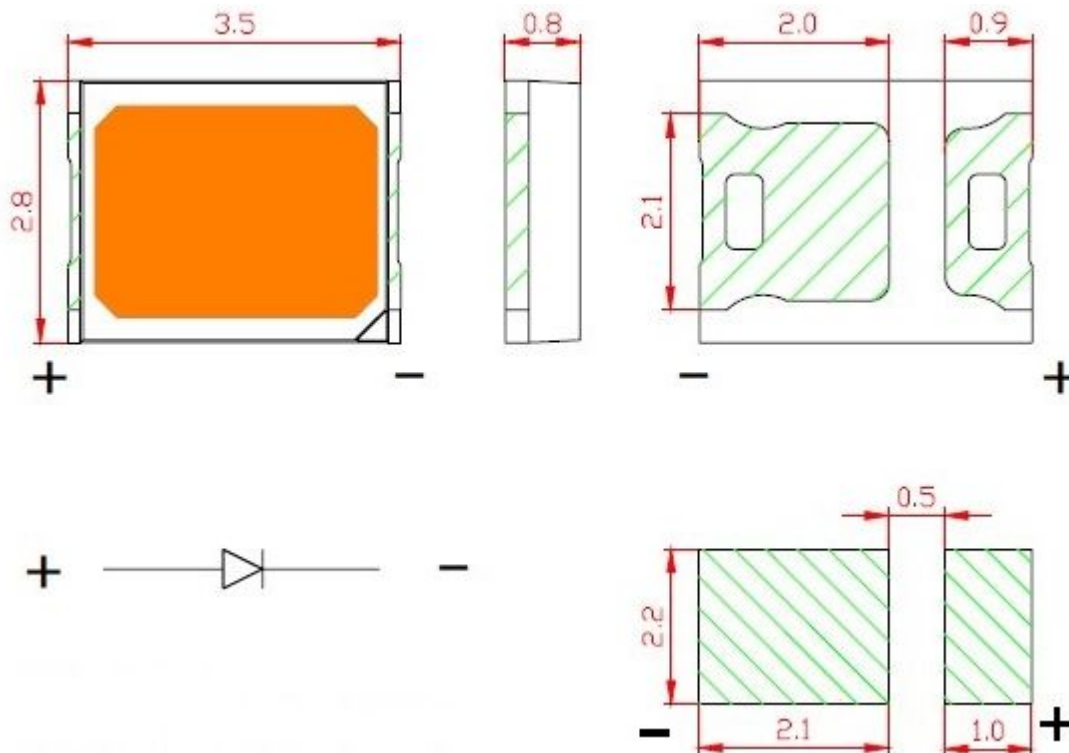

NOTES:

1. All dimensions are in millimeters (inches).
2. Tolerance is ± 0.10 mm unless otherwise specified.
3. Specifications are subject to change without notice.



2835 SMD LED

ESS-2835WWDT-R80-WR

REV:A / 0

※ **Absolute Maximum Ratings(Ta=25°C)**

Parameter	Symbol	Rating	Unit
Power Dissipation	Pd	0.2	W
Forward Current	I _F	60	mA
Peak Forward Current * 1	I _{FP}	150	mA
Reverse Voltage	V _R	5	V
Soldering Temperature	Tsol	240 (for 5 seconds)	°C
Operating Temperature	Topr	-40°C~85°C	-
Storage Temperature	Tstg	-40°C~85°C	-
Electrostatic discharge	ESD	2000	V

* 1 I_{FP} condition: pulse of 1/10 duty and 0.1ms width.

※ **Electrical-optical characteristics(Ta=25°C)**

Parameter	Symbol	Min.	Typ.	Max.	Unit	Condition
Forward Voltage	V _f	3.0		3.4	V	IF=60mA
Luminous Intensity	Lm	22		26	lm	
Viewing Angle	2θ _{1/2}	-	120		deg	
Reverse Current	I _R		-	10	μA	VR=5V
Color Rendering Index	Ra	80	---			IF=60mA
Color Temperature	CCT	2800	--	3500	K	IF=60mA

Note: 1. Tolerance of luminous intensity is ±10%

2. Tolerance of forward voltage is ±0.05V

※ Typical Electro-Optical Characteristics Curves

Relative Luminous Intensity Vs. Wavelength Ta=25°C

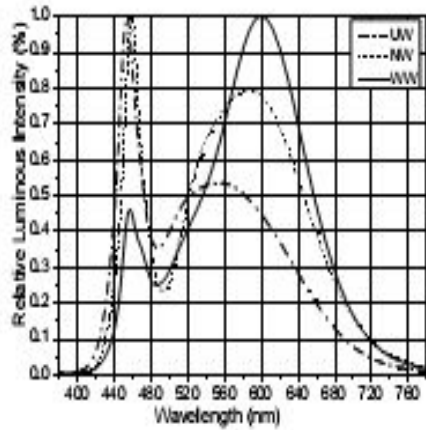

Forward Current vs Forward Voltage at Ta=25°C

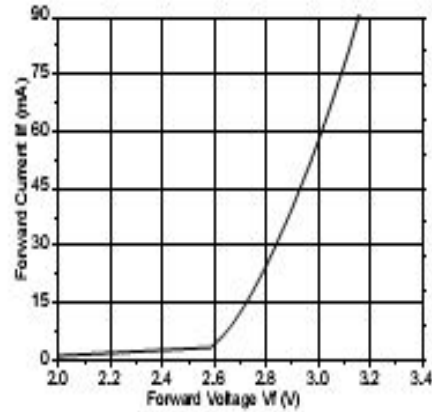

Forward Current Vs. Ambient Temperature

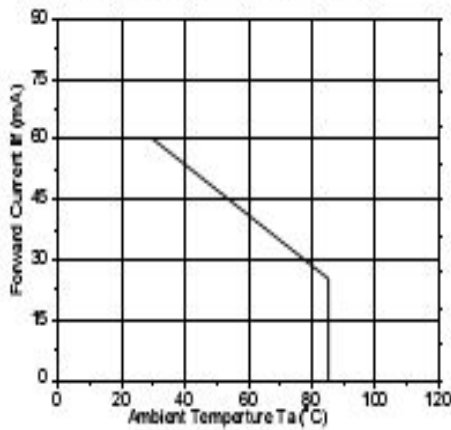

Forward Current Vs. Relative Luminosity Ta=25°C

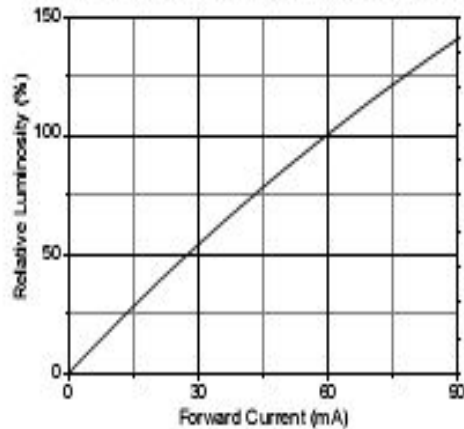

Relative Luminosity Vs. Ambient Temperature

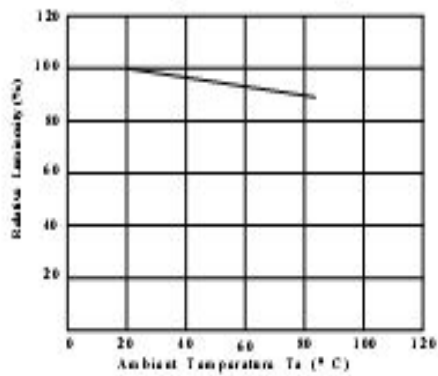

Radiation diagram

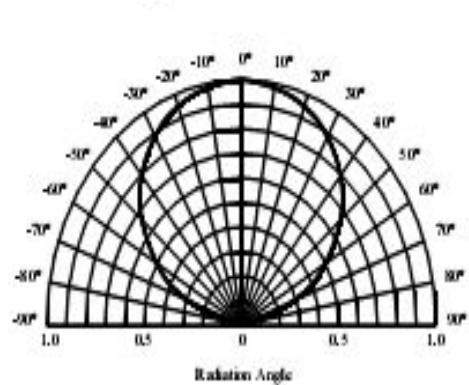

※ Typical photo electricity characteristic curve chart

CIE 1931 xy CHROMATICITY DIAGRAM

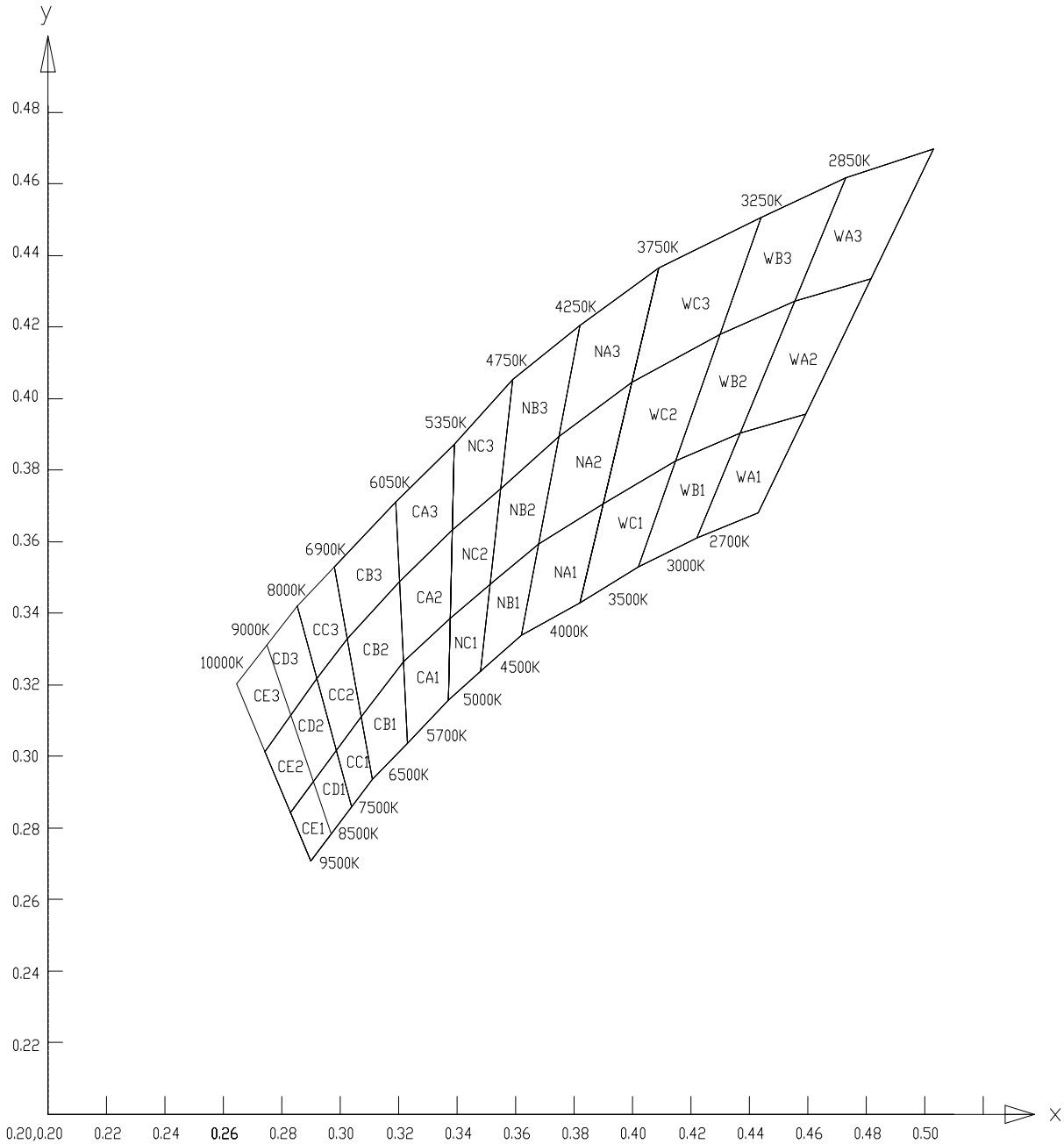



2835 SMD LED

ESS-2835WWDT-R80-WR

REV:A / 0

※BIN range

Forward voltage (tolerance is $\pm 0.05V$ @ $I_F=60mA$):

BIN CODE	Min. (V)	Max. (V)
S	2.9	3.0
T	3.0	3.1
U	3.1	3.2
V	3.2	3.3

Luminous intensity (tolerance is $\pm 10%$ @ $I_F=60mA$):

BIN CODE	Min.(lm)	Max.(lm)
B10	22	24
B11	24	26

※ Reliability test items and conditions:

No.	Test Item	Test Conditions	Sample size	Ac/Re
1	Operation Life	Test $I_F=DC60mA$ Temp: Room temperature Test time=1000hrs	22	0/1
2	High Temperature High Humidity	Temp. =+85°C RH=85%HR Test time=1000hrs	22	0/1
3	Thermal Shock	-35°C ~ +85°C 20min 10s 20min Test Time=300cycles	22	0/1
4	High Temperature Storage	High Temp. =+85°C Test time=1000hrs	22	0/1
5	Low Temperature Storage	Low $T_a=-35°C$ Test time=1000hrs	22	0/1
6	Temperature Cycle	-35°C ~ +100°C 15min 5min 15min Test Time=300cycle	22	0/1
7	Reflow Soldering	Operation heating: 240°C(Max.), within 10seconds. (Max.)	22	0/1

※ Judgment criteria of failure for the reliability

- I_v : Below 50% of initial values
- V_f : Over 20% of upper limit value
 - **IR: Over 2 times of upper limit value**

※ Package Tape Specifications: (1000 or 2000 pcs/Reel)

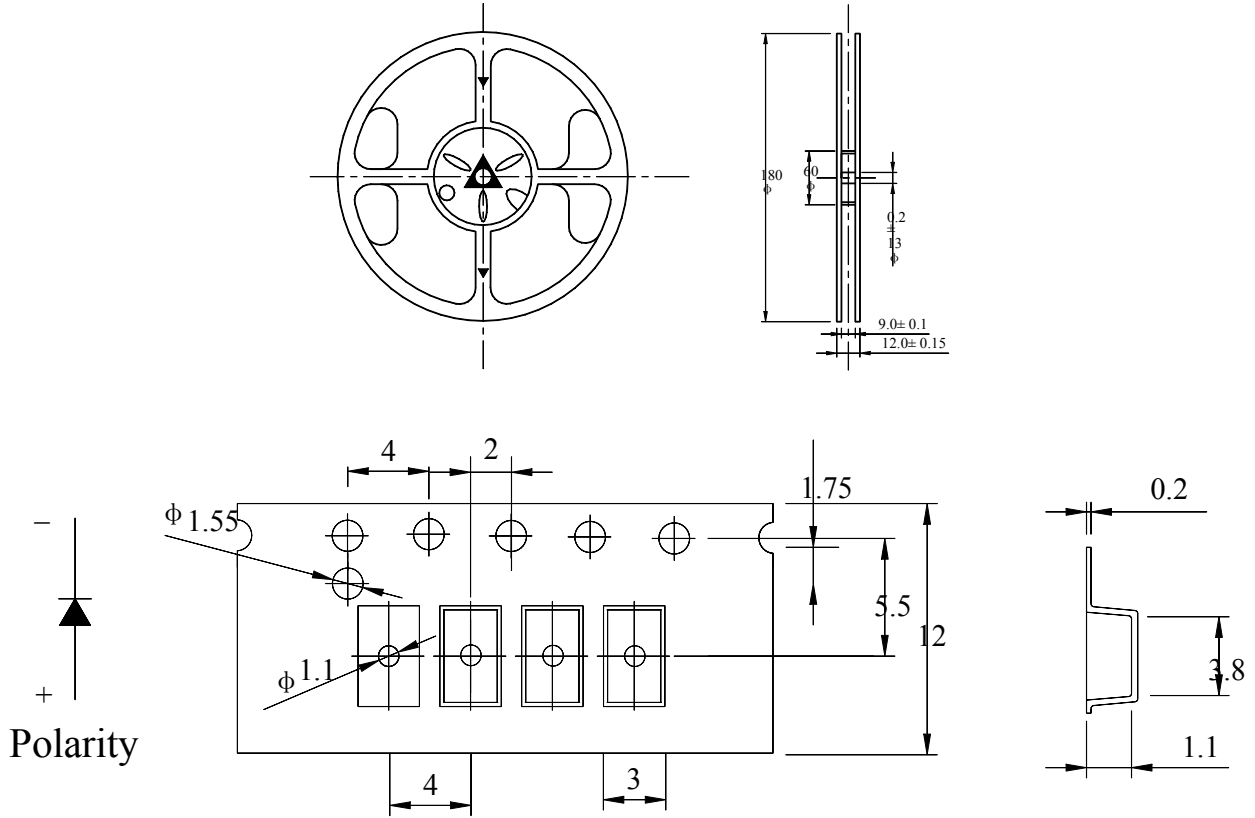

Reel Lead Min.60mm No LEDs

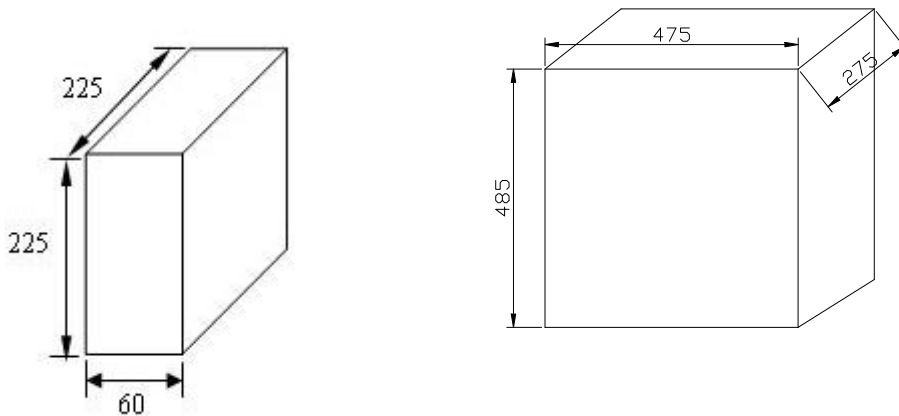

5 Reels in one Box

16 Boxes in one Carton



2835 SMD LED

ESS-2835WWDT-R80-WR

REV:A / 0

※ Precautions for use :

1. Customer must apply the current limiting resistor in the circuit so as to drive the LEDs within the rated current. Otherwise slight voltage shift maybe will cause big current change and burn out will happen.
2. Also, caution should be taken not to overload the LEDs with instantaneous high voltage at the turning ON and OFF of the circuit.
3. Storage:

3.1 Don't open the moisture proof bag before ready to use the LEDs.

3.2 The LEDs should be kept at 30 °C or less and 60%RH or less before opening the package.

The max. storage period before opening the package is 1 year.

3.3 After opening the package, the LEDs should be kept at 30 °C /35%RH or less, and it should

be used within 7 days.

3.4 If the LEDs be kept over the conditions of 3.4, baking is required before mounting.

Baking

condition as below: $60 \pm 5^{\circ}\text{C}$ for 12 hrs.

4. Soldering condition:

4.1 Manual of soldering:

The temp. of the iron should be lower than 260°C and soldering within 3sec per solder-pad is to be observed.

4.2 Pb-free solder temp. -time profile

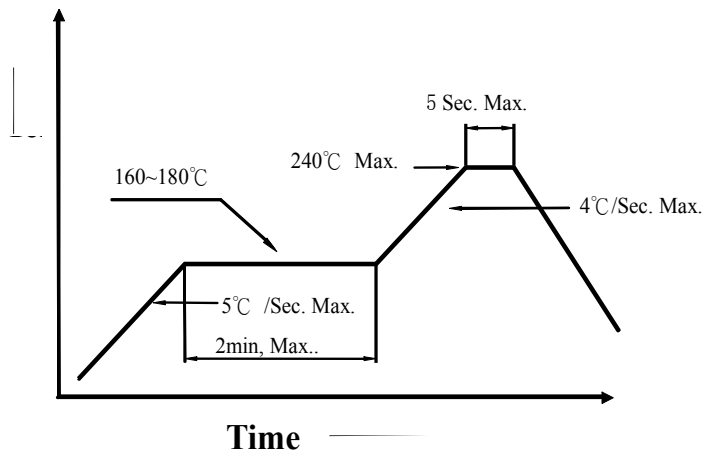

4.3 DIP soldering (Wave Soldering) temp. -time profile:

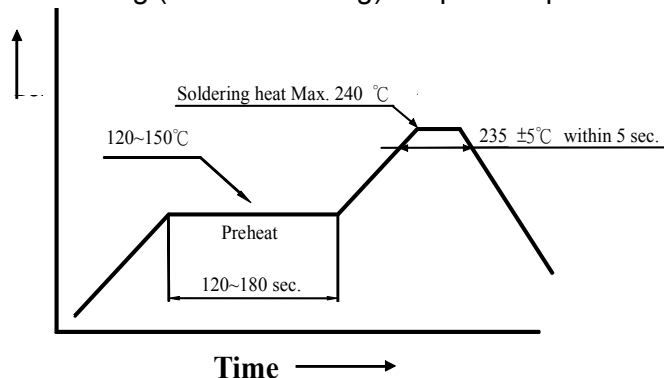

Note:

- a) Reflow soldering should not be done more than two times.
- b) Don't put stress on the LEDs when soldering.
- c) Don't warp the circuit board before it have been returned to normal ambient conditions after soldering.