

# ***MESSRS.***

---

## **SPECIFICATION FOR APPROVAL**

### **承 認 書**

<b>Product</b>	<b>MAGNETIC BUZZER( RoHS Grade )</b>
<b>Part No.</b>	<b>AC-1205G-LF</b>
<b>Customer Approval</b>	

<b>Approved By</b>	<b>Checked By</b>	<b>Made By</b>
工程 部 王台平 SEP-27-2006	工程 部 劉民祥 SEP-27-2006	工程 部 許俊程 SEP-27-2006



**ADVANCED ACOUSTIC TECHNOLOGY CORP.**

**苙 翔 科 技 股 份 有 限 公 司**



ISO 9001 Certified

2F, No.207, Sec. 6, Chung Shan N. Rd., Taipei, Taiwan.

Tel: +886-2-88665255

Fax: +886-2-88665250

e:<http://www.aatc.com.tw>

# 1. Specifications

AC-1205G-LF

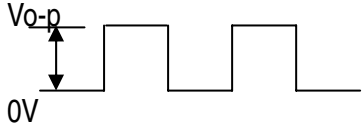
Items		Units	Specifications	Conditions
01	Rated Voltage	Vo-p	5.0	
02	Operating Voltage	Vo-p	4.0 ~ 8.0	
03	Consumption Current	mA (Max)	Mean 50	Applying rated voltage, rated frequency Square wave, 1/2 duty subject to standard state.
			Peak 150	
04	Direct Current Resistance	Ohm	40±6	
05	Sound Output	dBA (min)	85	Distance at 10cm, applying rated voltage, rated frequency square wave, 1/2 duty subject to standard state.
06	Rated Frequency	Hz	2400	
07	Operating Temp.	°C	-30 ~ +75	
08	Storage Temp.	°C	-40 ~ +85	
09	Weight	Gram	2	

## 2. Measuring Method

### 2-1. Test Condition

STANDARD

Temperature : 15 ~ 35°C

Relative humidity : 25% ~ 85%,

Atmospheric pressure : 860mbar to 1060mbar.

JUDGEMENT

Temperature : 20±3°C

Relative humidity : 60% ~ 70%,

Atmospheric pressure : 860mbar to 1060mbar

### 2-2. Standard Drive Circuit:

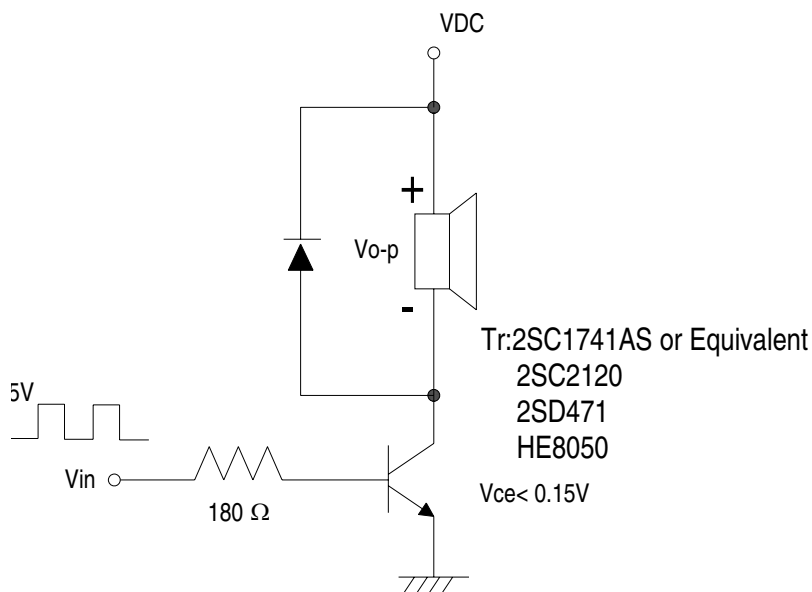

## 2-3. Standard Test Fixture

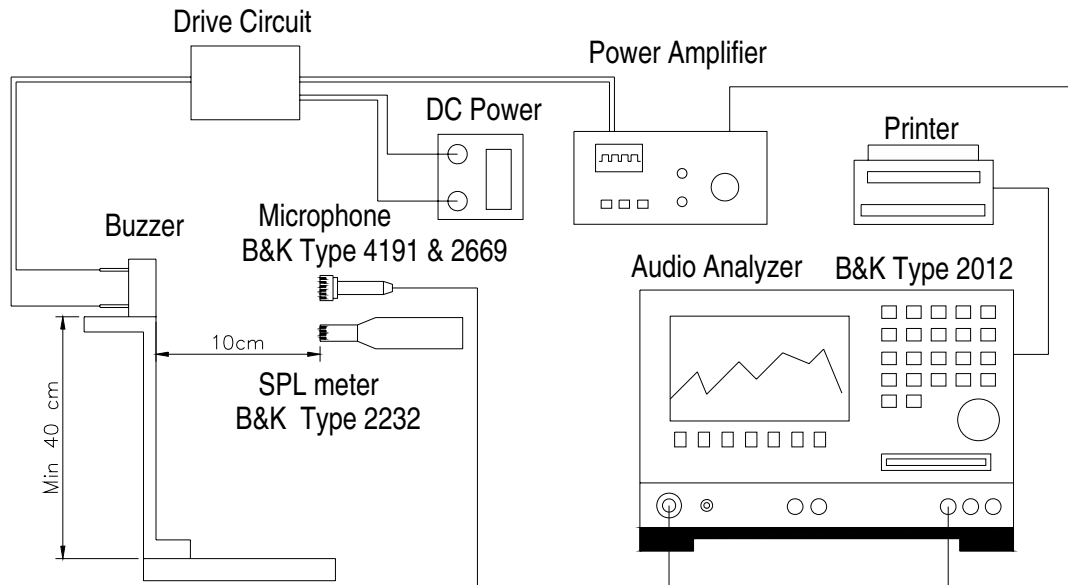

## 2-4. Frequency Response Curve

X:2.3714kHz Y:93.12dB ZA:Live Curve SSR T. RMS

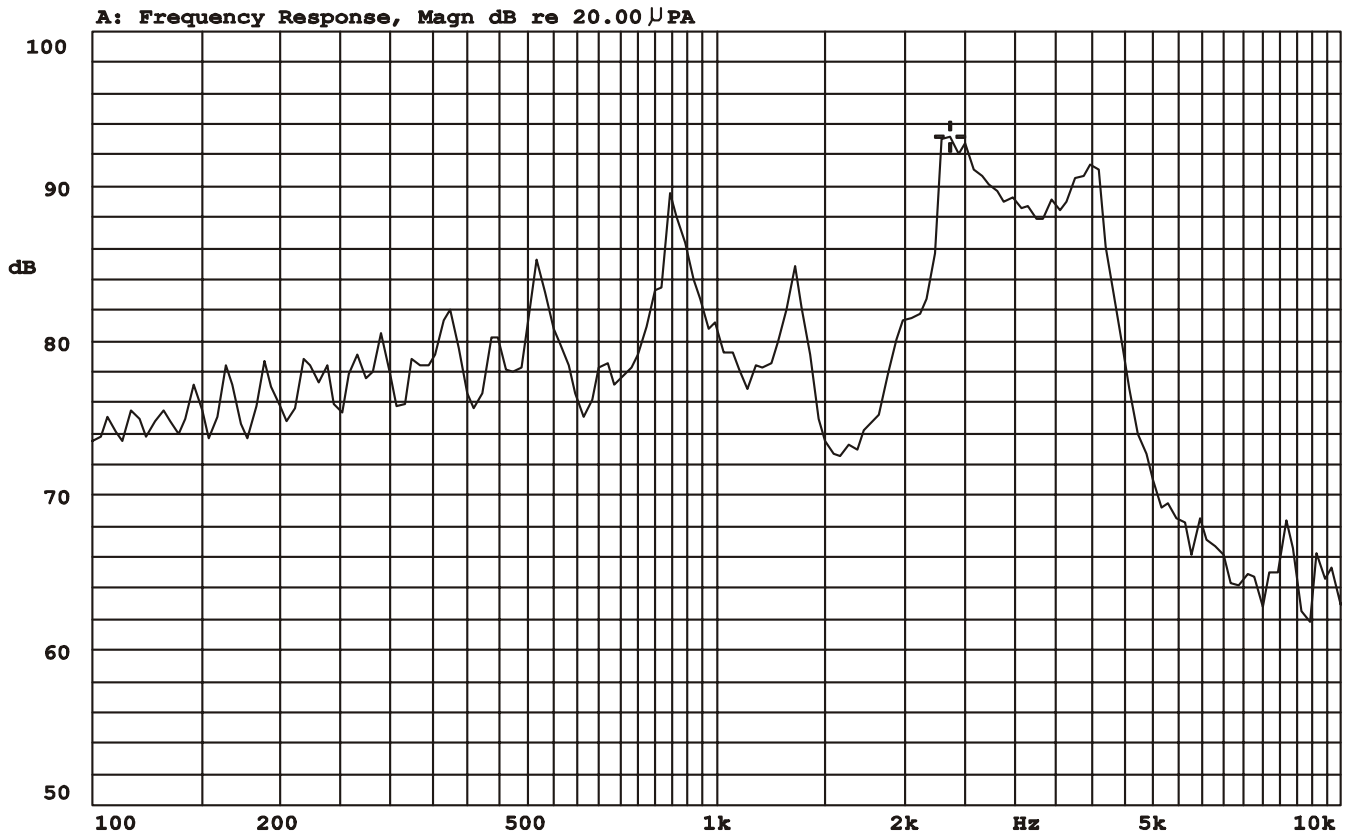

Mode: SSR



# ※ WAVE SOLDER AND WASH ALLOWED.

## ■ DIMENSION

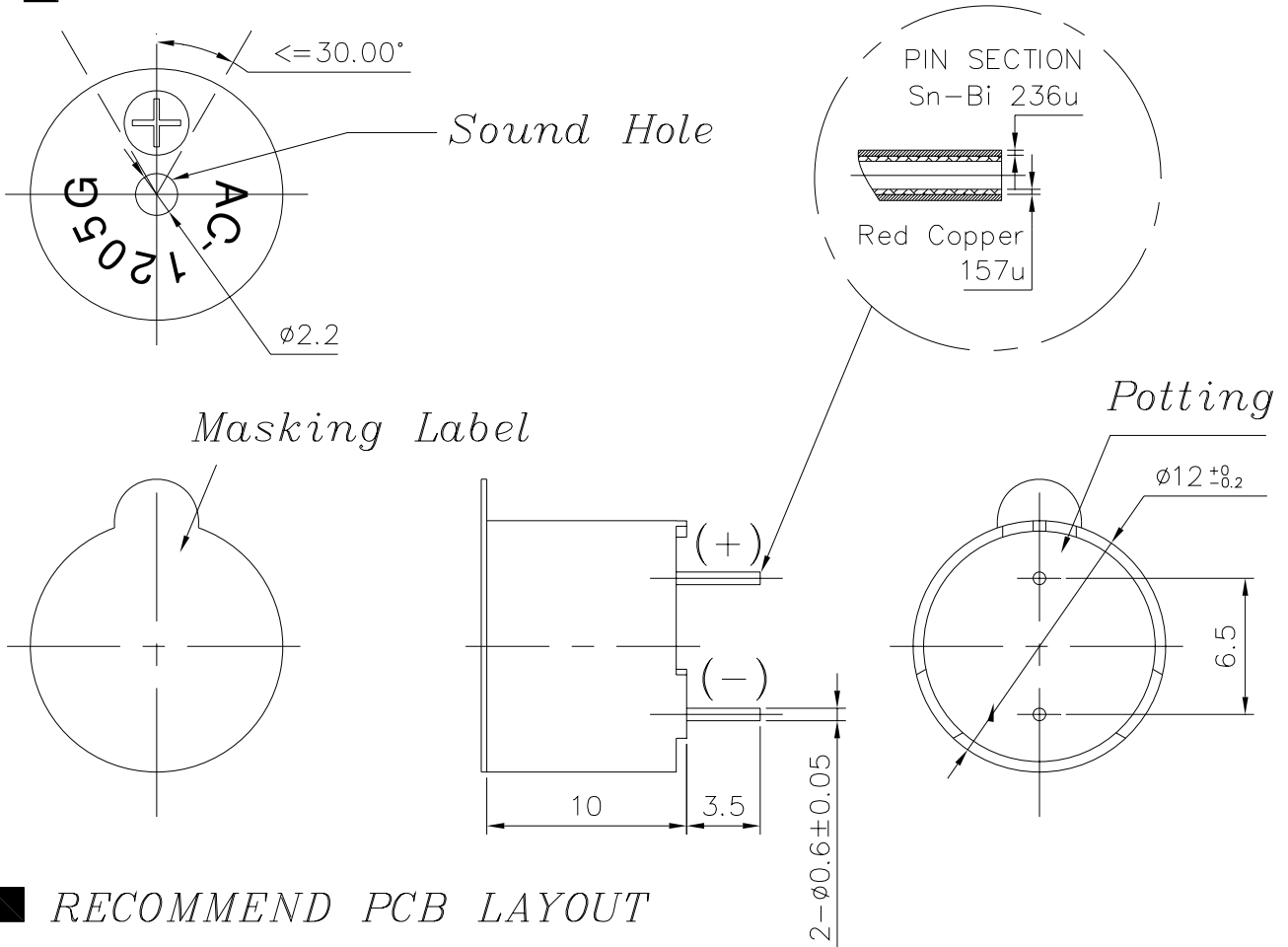

## ■ RECOMMEND PCB LAYOUT

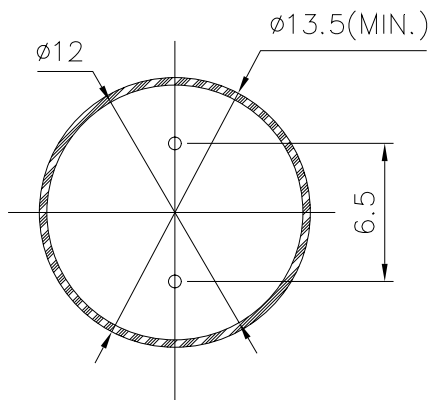

## PART NO. DESCRIPTION.

- A : COMPANY NAME
- C : MAGNETIC BUZZER
- |
- 12 : DIAMETER
- 05 : VOLTAGE
- G : RESISTANCE 40 ohm
- |
- LF : RoHS GRADE

TITLE: MAGNETIC BUZZER		DRAWN: <i>JOHN</i> 09/28/2006	SCALE: 3:1	SHEET: 1 OF 1
PART NO. AC-1205G-LF	1	DESIGNED: R&D OF AAT	UNITS: mm	
DWG NO. DTE-1135		CHECKED:	TOLERANCE $\pm 0.3$	
	REV	APPROVAL:	UNLESS OTHERWISE SPECIFIED:	
		MATERIAL: PBT 200°C	ONE PLACE DECIMAL $\pm$ ***	
			TWO PLACE DECIMAL $\pm$ ***	
			THREE PLACE DECIMAL $\pm$ ***	



苙翔科技股份有限公司

ADVANCED ACOUSTIC TECHNOLOGY CORPORATION

## 4. RELIABILITY TEST

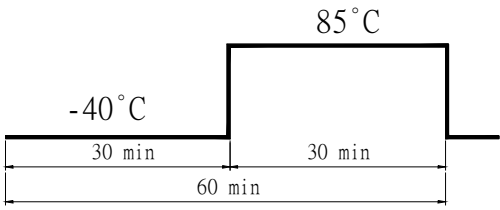
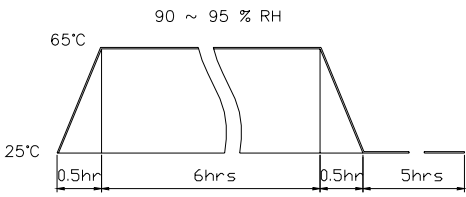
Item	Test conditions	Evaluation standard
01 High temp.Storage life	The part shall be capable of withstanding a storage Temperature of 85°C for 96 hours.	After the test the part shall meet specifications without Any degradation in appearance and performance except S.P.L S.P.L shall be 77dB or more.
02 Low temp.Storage life	The part shall be capable of withstanding a storage Temperature of -40°C for 96 hours.	
03 Temp. cycle	<p>The part shall be subjected 10 cycles. One cycle shall consist of;</p> 	
04 Temp./Humidity cycle	<p>The part shall be subjected 10 cycles. One cycle shall be 12 hours and consist of;</p> 	
05 Operating life	<p>Rated Voltage, Frequency applied.</p> <ol style="list-style-type: none"> <li>1. Ordinary temperature The part shall be subjected to 1000 hours at room temperature (25 ± 10°C)</li> <li>1. High temperature The part shall be subjected to 500 hours at 75°C</li> <li>2. Low temperature The part shall be subjected to 500 hours at -30°C</li> </ol>	
06 Vibration	<p>The part shall be subjected to a vibration cycle of 10Hz to 55Hz to 10Hz in a period of 1 minute. Total peak amplitude shall be 1.52mm (9.3G). The vibration test shall consist of 2 hours per plane in each three mutually perpendicular planes for a total time of 6 hours.</p>	

Item		Test conditions	Evaluation standard
07	<b>Fixed drop</b>	The part shall be mounted on standard pc board and dropped from a height of 152cm onto a concrete floor 5 times in each 6 planes.(a total of 30 times)	<p>After the test the part shall meet specifications without Any degradation in appearance and performance except S.P.L</p> <p>S.P.L shall be 77dB or more.</p>
08	<b>Free drop</b>	The part only shall be dropped from a height of 75cm onto a 40mm thick wooden board 3 times in 3 axes (X.Y.Z). (a total of 9 times).	
09	<b>Solder ability</b>	Soldering : $360\pm 5^{\circ}\text{C}$ / 2 Sec. Bath Soldering : $260\pm 10^{\circ}\text{C}$ / 2 Sec	
10	<b>Solder heat resistance</b>	Soldering into solderbath : $350\pm 5^{\circ}\text{C}$ / 3 Sec	
11	<b>Lead strength</b>	Pull lead with a force of 10N,on the direction of the lead axis for 10 : $10\pm 1$ sec	
12	<b>Washability</b>	Solvent : deionized water Solvent temp. : $55\pm 5^{\circ}\text{C}$ Soaking time : $5\pm 0.5$ min.	

REV NO.	REVISION NOTE	APPROVAL	DATE
---------	---------------	----------	------

1 FLAT = 100 PCS.

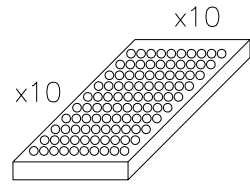

10 FLAT = 1 SMALL BOX

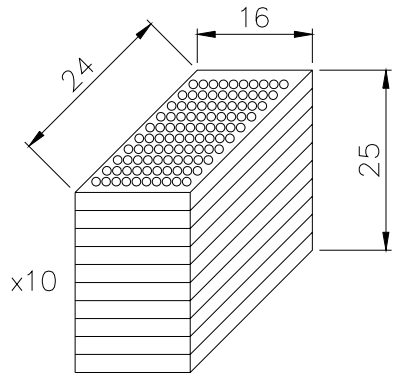

5 SMALL BOX = 1 BIG BOX

Gross Weight : 10Kgw.  
 Net Weight : 11.5Kgw.  
 MADE IN CHINA

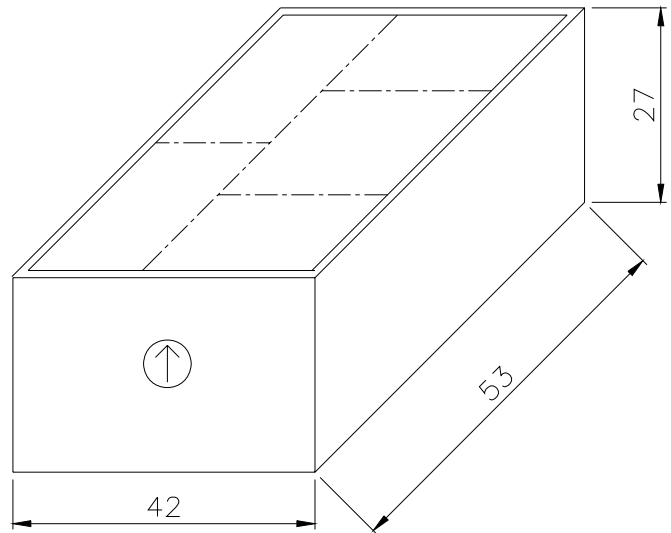

TITLE: PACKING	DRAWN: JOYEN 01/03/2005	SCALE:	SHEET:
PART NO. AC-1205G-LF	DESIGNED: R&D OF AAT	UNITS: cm	TOLERANCE ±
DWG NO.	1 REV	CHECKED:	UNLESS OTHERWISE SPECIFIED:
		APPROVAL:	ONE PLACE DECIMAL ± ***
		MATERIAL: *****	TWO PLACE DECIMAL ± ***
			THREE PLACE DECIMAL ± ***



苙翔科技股份有限公司  
 ADVANCED ACOUSTIC TECHNOLOGY CORPORATION