

TOP VIEW

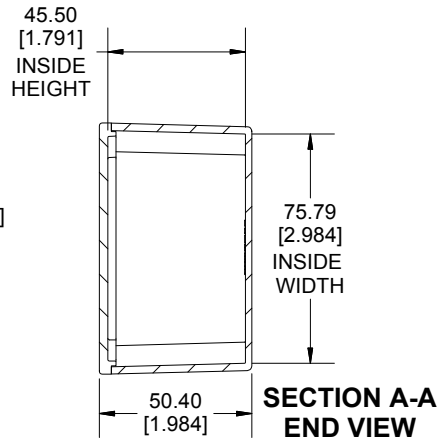

**SECTION A-A
END VIEW**

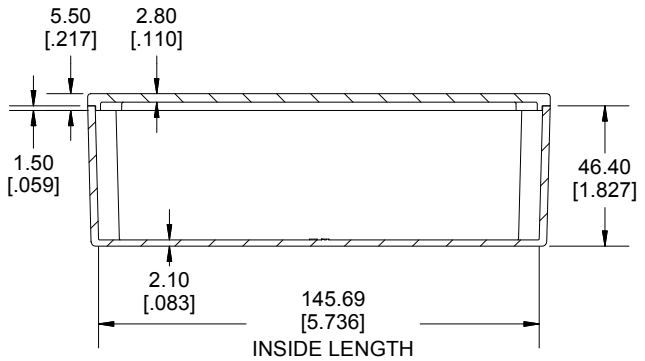

**SECTION B-B
SIDE VIEW**

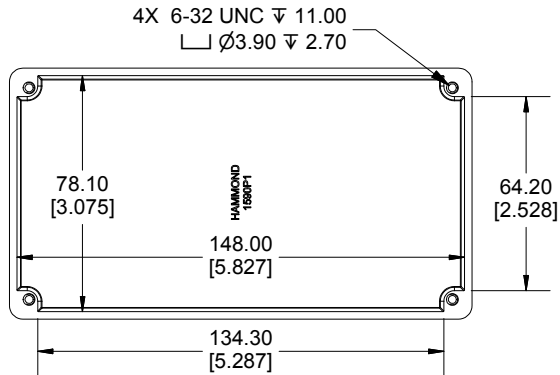

INSIDE BOX

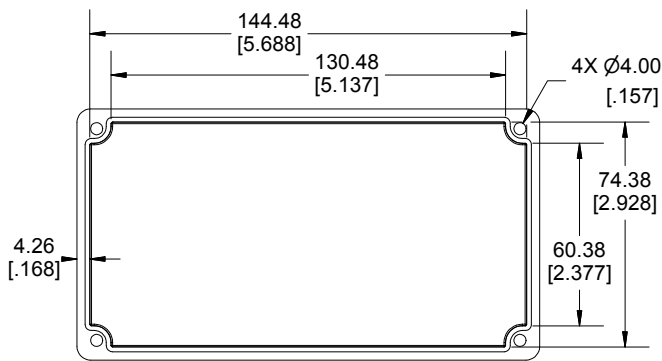

INSIDE LID

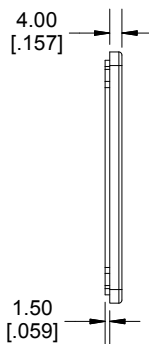

Enclosures can be Factory Modified (Milling, Drilling, Printing etc.)
 Contact Factory mjm@hammondmfg.com for quotes
 Solid models of this enclosure available in STEP or IGES.
 (Part number and text placement/orientation on our products are subject to change,
 we do not recommend using them as a locating reference for modification purposes)

| | |
|---|--|
| NOTE | |
| Purchased assembly includes box, lid and 4 cover screws. | |
| Box and lid are made from Diecast Aluminum Alloy. | |
| Silicone Gasket supplied with liquid resistant enclosure. | |
| Recommended Torque: 50-55 cN.m [71-78 ozf.in] | |
| Recommended Torque with Gasket : 25-30 cN.m [36-43 ozf.in] | |

| | |
|---|--------------|
| PART NUMBERS | |
| 1590P1 Enclosure | |
| Natural Finish Enclosure | 1590P1 |
| Black Textured Enclosure | 1590P1BK |
| 1590P1 Liquid Resistant Enclosure (Silicone Gasket) | |
| Natural Finish Enclosure | 1590WP1 |
| Black Textured Enclosure | 1590WP1BK |
| ACCESSORIES | |
| Liquid Resistant Cover Screws | |
| Stainless Steel Cover Screws (Pkg 100) [6-32 x 1/2" With O-Ring] | 1590WMS100 |
| Black Stainless Steel Cover Screws (Pkg 100) [6-32 x 1/2" With O-Ring] | 1590WMS100BK |
| Standard Cover Screws | |
| Plated Cover Screws (Pkg 100) [6-32 x 1/2"] | 1590MS100 |
| Black Cover Screws (Pkg 100) [6-32 x 1/2"] | 1590MS100BK |

**HAMMOND
MANUFACTURING®**

1590P1

www.hammondmfg.com

Dimensions:
mm
[inches]