

REVISION RECORD				
REV	ECN	DESCRIPTION	DRFT	DATE

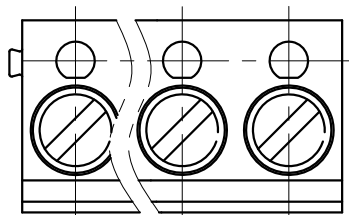

NOTES1:

UL Standard

1. Rated Voltage/Current : 300V / 10A
2. Torque Value : M3 , 2.6Lb.in
3. Wire Range : 22~14AWG

IEC Standard

1. Rated Voltage/Current : 250V / 24A
2. Torque Value : M3 , 0.29N.m
3. Wire Range : 2.5mm²

NOTES2:

1. Dimension shall be interpreted per ASME Y14.5-2009
2. Pitch : 5.0mm, Poles : N=02~24P
3. Stripping length : 5~6mm
4. Withstanding Voltage : AC2000V/1Min.
5. Operating temperature : -30°C~+120°C
6. Undimensioned Tolerances:

Pitch Range In mm		Nominal Dimension Range In mm					
TO	Over TO	TO	Over TO	TO	Over TO	0.1/10	
6	10	30	60	100	150	<	
±0.15	±0.20	±0.30	±0.50	±0.70	±1.00	±1.30	±2°

7. RoHS Compliance

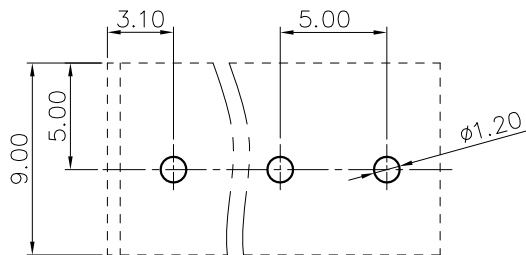
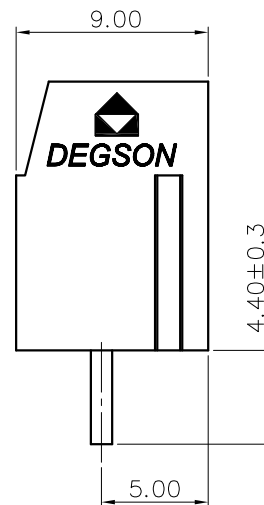
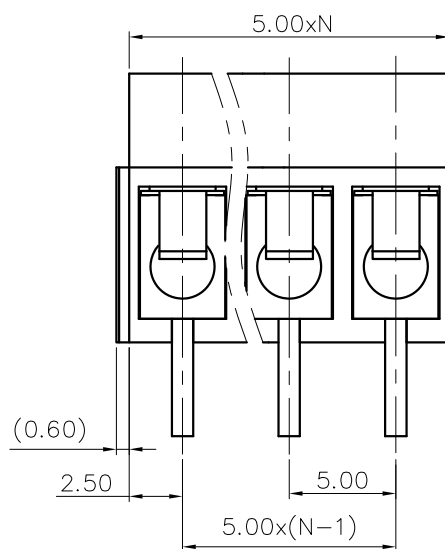
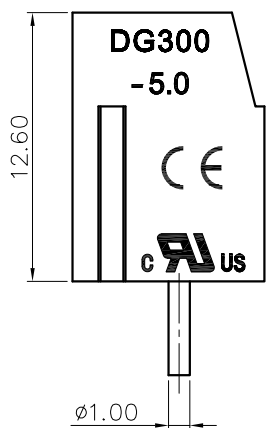

PCB LAYOUT

DG300 - 5.0 - XXP - 1Y - 00A (H)
 (Series No.) (Pitch) (Poles) (Single Pitch) (Color): 1.(Grey)
 2.(Blue)
 3.(Black)
 4.(Green)
 5.(Orange)
 6.(Red)
 7.(Transparent)
 8.(Yellow)
 9.(White)

DETACHED LISTS	PART NO.:	NINGBO DEGSON ELECTRICAL CO., LTD			
	APPD:	NAME: DG300-5.0-XXP-1Y-00A(H)			
	CHKD:	TITLE: CUSTOMER DRAWING			
	DRFT:	DRAWING NO.:		REV	DO
THIRD ANGLE PROJECTION		MM (INCH)	DO NOT SCALE DRAWING	SHEET 1/1	SCALE 1:1