

MAX232, MAX232I DUAL EIA-232 DRIVER/RECEIVER

SLLS047G – FEBRUARY 1989 – REVISED AUGUST 1998

- Operates With Single 5-V Power Supply
- LinBiCMOS™ Process Technology
- Two Drivers and Two Receivers
- ±30-V Input Levels
- Low Supply Current . . . 8 mA Typical
- Meets or Exceeds TIA/EIA-232-F and ITU Recommendation V.28
- Designed to be Interchangeable With Maxim MAX232
- Applications
 - TIA/EIA-232-F
 - Battery-Powered Systems
 - Terminals
 - Modems
 - Computers
- ESD Protection Exceeds 2000 V Per MIL-STD-883, Method 3015
- Package Options Include Plastic Small-Outline (D, DW) Packages and Standard Plastic (N) DIPs

description

The MAX232 device is a dual driver/receiver that includes a capacitive voltage generator to supply EIA-232 voltage levels from a single 5-V supply. Each receiver converts EIA-232 inputs to 5-V TTL/CMOS levels. These receivers have a typical threshold of 1.3 V and a typical hysteresis of 0.5 V, and can accept ±30-V inputs. Each driver converts TTL/CMOS input levels into EIA-232 levels. The driver, receiver, and voltage-generator functions are available as cells in the Texas Instruments LinASIC™ library.

The MAX232 is characterized for operation from 0°C to 70°C. The MAX232I is characterized for operation from -40°C to 85°C.

D, DW, OR N PACKAGE
(TOP VIEW)

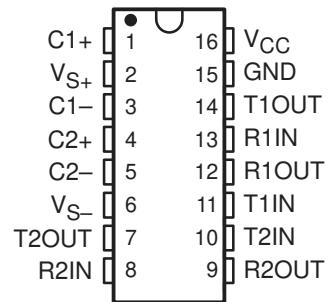

logic symbol†

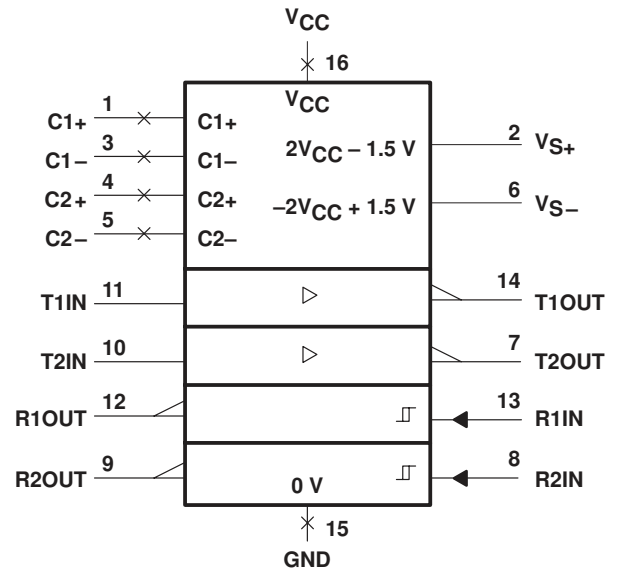

† This symbol is in accordance with ANSI/IEEE Std 91-1984 and IEC Publication 617-12.

AVAILABLE OPTIONS

T _A	PACKAGED DEVICES		
	SMALL OUTLINE (D)	SMALL OUTLINE (DW)	PLASTIC DIP (N)
0°C to 70°C	MAX232D‡	MAX232DW‡	MAX232N
-40°C to 85°C	MAX232ID‡	MAX232IDW‡	MAX232IN

‡ This device is available taped and reeled by adding an R to the part number (i.e., MAX232DR).



Please be aware that an important notice concerning availability, standard warranty, and use in critical applications of Texas Instruments semiconductor products and disclaimers thereto appears at the end of this data sheet.

LinASIC and LinBiCMOS are trademarks of Texas Instruments Incorporated.

PRODUCTION DATA information is current as of publication date. Products conform to specifications per the terms of Texas Instruments standard warranty. Production processing does not necessarily include testing of all parameters.



POST OFFICE BOX 655303 • DALLAS, TEXAS 75265

Copyright © 1998, Texas Instruments Incorporated

MAX232, MAX232I DUAL EIA-232 DRIVER/RECEIVER

SLLS047G – FEBRUARY 1989 – REVISED AUGUST 1998

absolute maximum ratings over operating free-air temperature range (unless otherwise noted)†

Input supply voltage range, V_{CC} (see Note 1)	-0.3 V to 6 V
Positive output supply voltage range, V_{S+}	$V_{CC} - 0.3$ V to 15 V
Negative output supply voltage range, V_{S-}	-0.3 V to -15 V
Input voltage range, V_I : Driver	-0.3 V to $V_{CC} + 0.3$ V
Receiver	± 30 V
Output voltage range, V_O : T1OUT, T2OUT	$V_{S-} - 0.3$ V to $V_{S+} + 0.3$ V
R1OUT, R2OUT	-0.3 V to $V_{CC} + 0.3$ V
Short-circuit duration: T1OUT, T2OUT	Unlimited
Package thermal impedance, θ_{JA} (see Note 2): D package	113°C/W
DW package	105°C/W
N package	78°C/W
Storage temperature range, T_{stg}	-65°C to 150°C
Lead temperature 1,6 mm (1/16 inch) from case for 10 seconds	260°C

† Stresses beyond those listed under “absolute maximum ratings” may cause permanent damage to the device. These are stress ratings only, and functional operation of the device at these or any other conditions beyond those indicated under “recommended operating conditions” is not implied. Exposure to absolute-maximum-rated conditions for extended periods may affect device reliability.

NOTE 1: All voltage values are with respect to network ground terminal.

2. The package thermal impedance is calculated in accordance with JESD 51, except for through-hole packages, which use a trace length of zero.

recommended operating conditions

		MIN	NOM	MAX	UNIT
Supply voltage, V_{CC}		4.5	5	5.5	V
High-level input voltage, V_{IH} (T1IN, T2IN)		2			V
Low-level input voltage, V_{IL} (T1IN, T2IN)				0.8	V
Receiver input voltage, R1IN, R2IN				± 30	V
Operating free-air temperature, T_A	MAX232	0		70	°C
	MAX232I	-40		85	



electrical characteristics over recommended ranges of supply voltage and operating free-air temperature range (unless otherwise noted)

PARAMETER		TEST CONDITIONS	MIN	TYP†	MAX	UNIT		
V _{OH}	High-level output voltage	T1OUT, T2OUT	R _L = 3 kΩ to GND		5	7	V	
		R1OUT, R2OUT	I _{OH} = -1 mA		3.5			
V _{OL}	Low-level output voltage‡	T1OUT, T2OUT	R _L = 3 kΩ to GND		-7	-5	V	
		R1OUT, R2OUT	I _{OL} = 3.2 mA		0.4			
V _{IT+}	Receiver positive-going input threshold voltage	R1IN, R2IN	V _{CC} = 5 V,	T _A = 25°C	1.7	2.4	V	
V _{IT-}	Receiver negative-going input threshold voltage	R1IN, R2IN	V _{CC} = 5 V,	T _A = 25°C	0.8	1.2	V	
V _{hys}	Input hysteresis voltage	R1IN, R2IN	V _{CC} = 5 V		0.2	0.5	1	V
r _i	Receiver input resistance	R1IN, R2IN	V _{CC} = 5,	T _A = 25°C	3	5	7	kΩ
r _o	Output resistance	T1OUT, T2OUT	V _{S+} = V _{S-} = 0, V _O = ± 2 V		300			Ω
I _{OS} §	Short-circuit output current	T1OUT, T2OUT	V _{CC} = 5.5 V, V _O = 0		±10			mA
I _{IS}	Short-circuit input current	T1IN, T2IN	V _I = 0				200	μA
I _{CC}	Supply current		V _{CC} = 5.5 V, T _A = 25°C	All outputs open,	8	10		mA

† All typical values are at V_{CC} = 5 V, T_A = 25°C.

‡ The algebraic convention, in which the least positive (most negative) value is designated minimum, is used in this data sheet for logic voltage levels only.

§ Not more than one output should be shorted at a time.

switching characteristics, V_{CC} = 5 V, T_A = 25°C

PARAMETER		TEST CONDITIONS	MIN	TYP	MAX	UNIT
t _{PLH(R)}	Receiver propagation delay time, low- to high-level output	See Figure 1		500		ns
t _{PHL(R)}	Receiver propagation delay time, high- to low-level output	See Figure 1		500		ns
SR	Driver slew rate	R _L = 3 kΩ to 7 kΩ, See Figure 2			30	V/μs
SR(tr)	Driver transition region slew rate	See Figure 3		3		V/μs

MAX232, MAX232I DUAL EIA-232 DRIVER/RECEIVER

SLLS047G – FEBRUARY 1989 – REVISED AUGUST 1998

PARAMETER MEASUREMENT INFORMATION

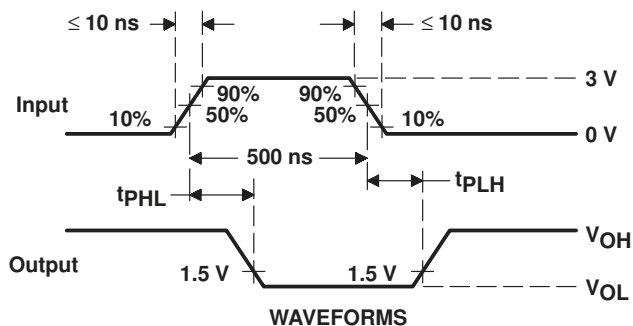
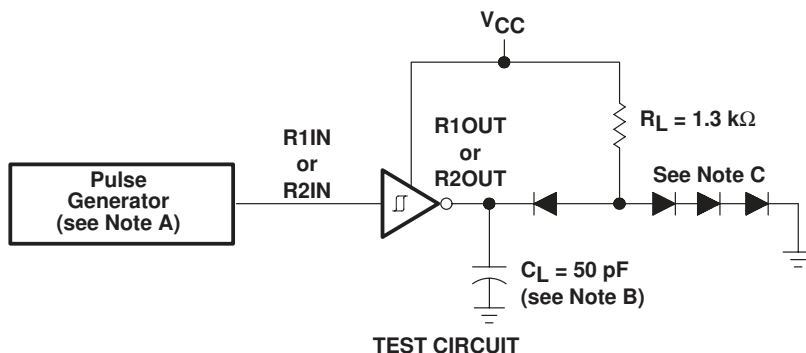

- NOTES: A. The pulse generator has the following characteristics: $Z_O = 50 \Omega$, duty cycle $\leq 50\%$.
 B. C_L includes probe and jig capacitance.
 C. All diodes are 1N3064 or equivalent.

Figure 1. Receiver Test Circuit and Waveforms for t_{PHL} and t_{PLH} Measurements

PARAMETER MEASUREMENT INFORMATION

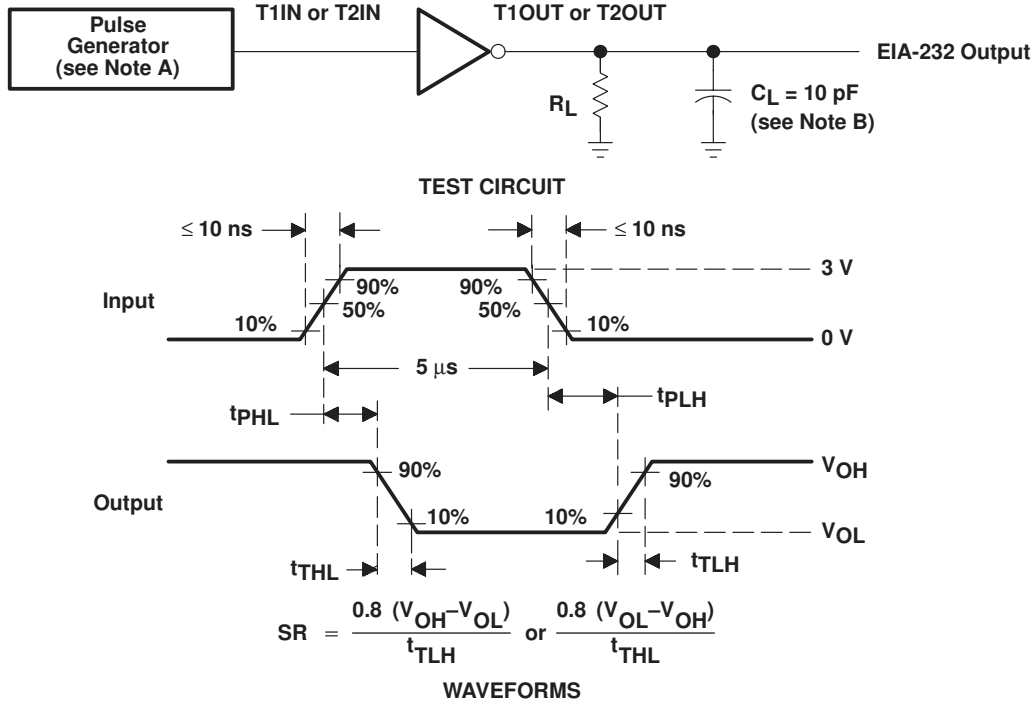

NOTES: A. The pulse generator has the following characteristics: $Z_O = 50 \Omega$, duty cycle $\leq 50\%$.
B. C_L includes probe and jig capacitance.

Figure 2. Driver Test Circuit and Waveforms for t_{PHL} and t_{PLH} Measurements (5- μs input)

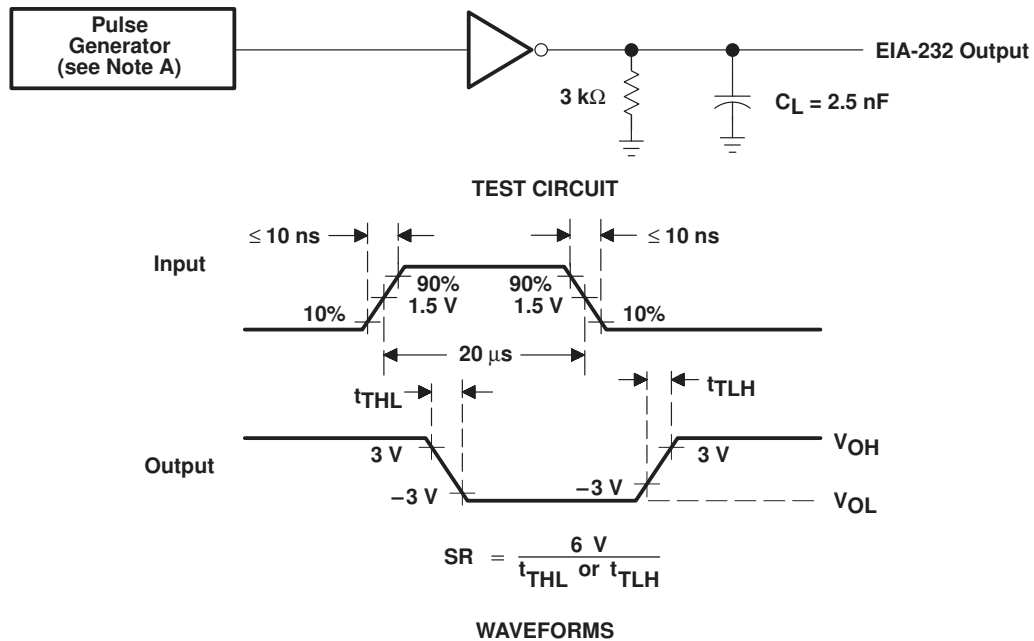

NOTE A: The pulse generator has the following characteristics: $Z_O = 50 \Omega$, duty cycle $\leq 50\%$.

Figure 3. Test Circuit and Waveforms for t_{THL} and t_{TLH} Measurements (20- μs input)

MAX232, MAX232I DUAL EIA-232 DRIVER/RECEIVER

SLLS047G – FEBRUARY 1989 – REVISED AUGUST 1998

APPLICATION INFORMATION

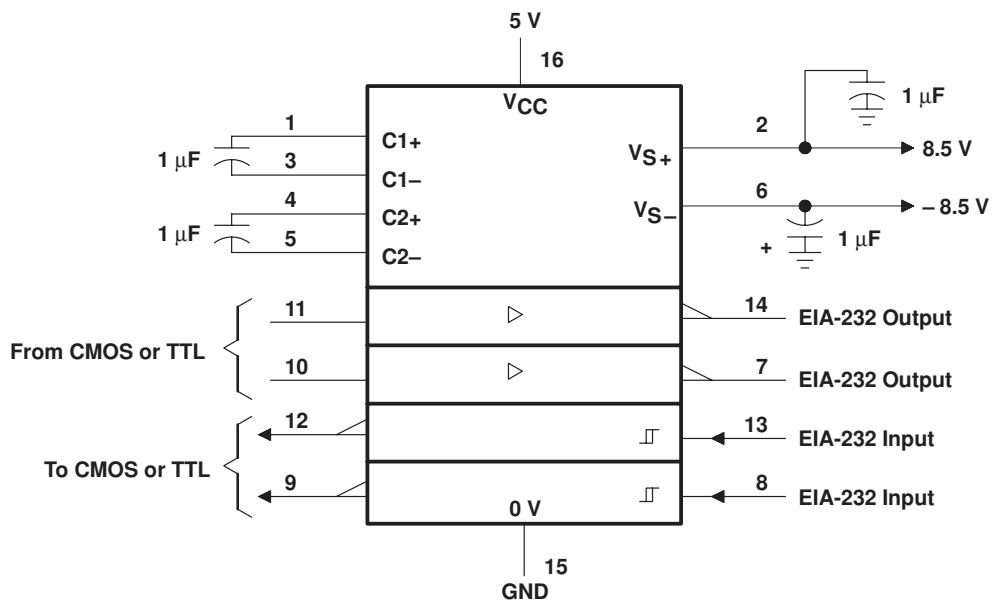

Figure 4. Typical Operating Circuit

IMPORTANT NOTICE

Texas Instruments and its subsidiaries (TI) reserve the right to make changes to their products or to discontinue any product or service without notice, and advise customers to obtain the latest version of relevant information to verify, before placing orders, that information being relied on is current and complete. All products are sold subject to the terms and conditions of sale supplied at the time of order acknowledgement, including those pertaining to warranty, patent infringement, and limitation of liability.

TI warrants performance of its semiconductor products to the specifications applicable at the time of sale in accordance with TI's standard warranty. Testing and other quality control techniques are utilized to the extent TI deems necessary to support this warranty. Specific testing of all parameters of each device is not necessarily performed, except those mandated by government requirements.

CERTAIN APPLICATIONS USING SEMICONDUCTOR PRODUCTS MAY INVOLVE POTENTIAL RISKS OF DEATH, PERSONAL INJURY, OR SEVERE PROPERTY OR ENVIRONMENTAL DAMAGE ("CRITICAL APPLICATIONS"). TI SEMICONDUCTOR PRODUCTS ARE NOT DESIGNED, AUTHORIZED, OR WARRANTED TO BE SUITABLE FOR USE IN LIFE-SUPPORT DEVICES OR SYSTEMS OR OTHER CRITICAL APPLICATIONS. INCLUSION OF TI PRODUCTS IN SUCH APPLICATIONS IS UNDERSTOOD TO BE FULLY AT THE CUSTOMER'S RISK.

In order to minimize risks associated with the customer's applications, adequate design and operating safeguards must be provided by the customer to minimize inherent or procedural hazards.

TI assumes no liability for applications assistance or customer product design. TI does not warrant or represent that any license, either express or implied, is granted under any patent right, copyright, mask work right, or other intellectual property right of TI covering or relating to any combination, machine, or process in which such semiconductor products or services might be or are used. TI's publication of information regarding any third party's products or services does not constitute TI's approval, warranty or endorsement thereof.