

FOR 客户名称	APPROVED 客户确认签字	ATTN 销售负责人

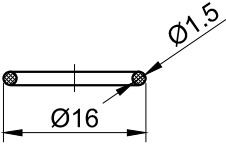
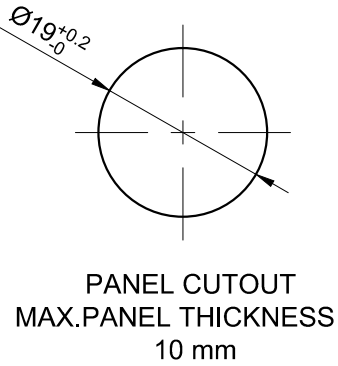
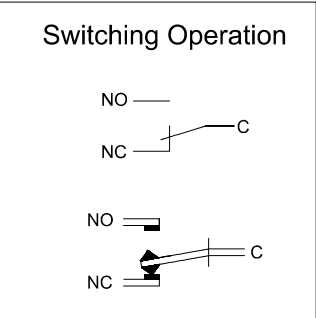
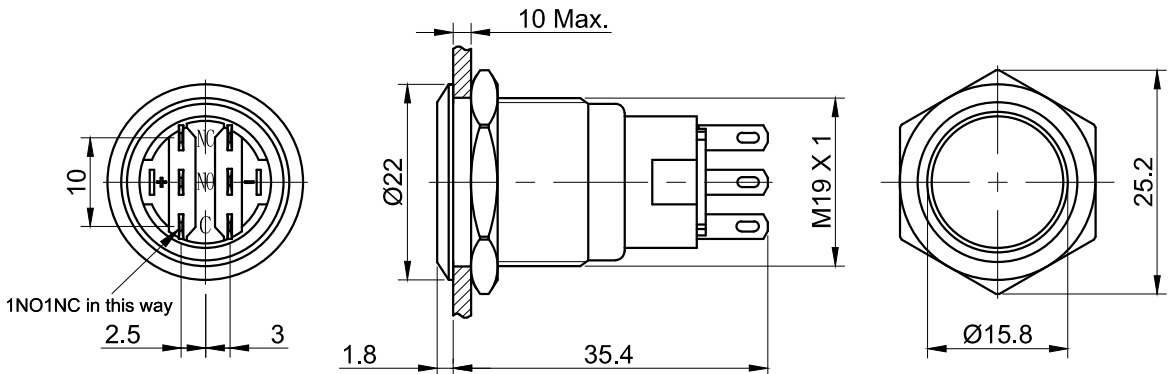

Part Number: LAS1-AGQ-□■/S

□	Contact structure	■	Operation mode
11	1NO 1NC	No Letter	Momentary
22	2NO 2NC	Z	Latching

SPECIFICATIONS:

- 1.Switch Rating: AC250V/0.5A, DC110V/0.1A.
- 2.Mechanical Life: ≥1,000,000cycles.
- 3.Electrical Life: ≥50,000cycles.
- 4.Contact Resistance: ≤50mΩ.
- 5.Insulation Resistance: ≥1,000MΩ.
- 6.Dielectric Strength: 1,500V, RMS 50Hz , 1min.
- 7.Operating Temperature: -25℃~ +55℃(No Freezing).
- 8.Operating Force: About 1.5N(1NO1NC),About 3N(2NO2NC).
- 9.Operating Travel: About 3.1mm.
- 10.Torque: About 0.6Nm max.applied to nut.
- 11.Protection degree: IP65;IK09.
- 12.Terminal Type: Pin Terminal(2.8 x 0.5mm).

MATERIALS:

- 1.Contact: Silver alloy.
- 2.Button: Stainless Steel.
- 3.Body: Stainless Steel.
- 4.Base: PBT.

BRAND 品牌 ONPOW	红波按钮制造有限公司 ONPOW PUSH BUTTON MANUFACTURE CO.,LTD.		
	THESE DRAWINGS AND SPECIFICATIONS ARE THE PROPERTY OF ONPOW PUSH BUTTON MANUFACTURE CO.,LTD. AND SHALL NOT BE REPRODUCED COPIED OR USED IN ANY MANNER WITHOUT THE PRIOR WRITTEN CONSENT OF ONPOW PUSH BUTTON MANUFACTURE CO.,LTD.	USED 用途	APPD 审核
	FINISH 处理	CHKD 校对	CH 2020/04/23 NCH 2020/04/23
	SCALE 比例	UNIT 单位	DR. 制图
	1.2 / 1	mm	ZPD 2020/04/23
DIMENSIONS	TOLERANCE	TITLE 名称	
0.00 TO 18.00mm	±0.43mm	GQ Series Anti-vandal push button	
18.01 TO 30.00mm	±0.52mm	DWG NO. 图号	SIZE 图纸
30.01 TO 50.00mm	±0.62mm	LAS1-AGQ-S不带灯	A4
50.01 TO 80.00mm	±0.74mm	FILE NAME 档案名称	SHEET 张
		LAS1-AGQ不带灯.DWG	1 / 1
		REV. 更改	1