



User Manual

EE895
MINIATURE SENSOR MODULE
FOR CO₂, TEMPERATURE AND
BAROMETRIC PRESSURE

YOUR PARTNER IN SENSOR TECHNOLOGY



E+E Elektronik Ges.m.b.H. does not accept warranty and liability claims neither upon this publication nor in case of improper treatment of the described products.

The document may contain technical inaccuracies and typographical errors. The content will be revised on a regular basis. These changes will be implemented in later versions. The described products can be improved and changed at any time without prior notice.

© Copyright E+E Elektronik Ges.m.b.H. All rights reserved.

EMC note USA (FCC):

This equipment has been tested and found to comply with the limits for a Class A digital device, pursuant to part 15 of the FCC Rules. These limits are designed to provide reasonable protection against harmful interference when the equipment is operated in a commercial environment. This equipment generates, uses, and can radiate radio frequency energy and, if not installed and used in accordance with the instruction manual, may cause harmful interference to radio communications. Operation of this equipment in a residential area is likely to cause harmful interference in which case the user will be required to correct the interference at his own expense.

EMC note Canada (ICES-003):

CAN ICES-3 (A) / NMB-3 (A)

CONTENTS

1	Introduction	4
1.1	General.....	4
1.2	Explanation of Symbols.....	4
1.3	Safety Instructions.....	4
1.3.1	General Safety Instructions.....	4
1.3.2	Intended Use.....	4
1.4	Environmental Aspects.....	5
1.5	Product Description.....	5
1.6	Operating Principle CO ₂ Measurement.....	5
2	Handling Instructions	5
3	Hardware.....	6
3.1	Dimensions.....	6
3.2	Mounting Recommendation	6
3.2.1	Mounting via Solder Pads	6
3.2.2	Mounting via Side Plated Contacts	7
3.3	EE895 Block Diagram	7
3.4	Pin Assignment.....	8
3.5	Pin Description	8
3.6	Electrical Characteristics.....	10
3.7	Typical Applications.....	11
3.7.1	EE895 Connected to USB Interface	11
3.7.2	EE895 in Battery Powered Devices	11
3.7.3	EE895 Connected to a KNX Bus	12
4	Digital Interface	12
4.1	I ² C Interface.....	12
4.1.1	Modbus Protocol Over I ² C Interface.....	12
4.1.2	I ² C Simplified Protocol	13
4.2	UART Interface.....	15
4.2.1	Modbus Protocol Over UART Interface	15
4.3	Modbus Register Map	15
4.4	General Purpose Registers for Individual Use	16
4.5	EE895 Commands	16
4.5.1	Information	16
4.5.2	General Settings	17
4.5.3	CO ₂ Parameter Settings.....	18
5	Technical Data	20

1 Introduction

1.1 General

This user manual serves for ensuring proper handling and optimal functioning of the device. It shall be read before commissioning and it shall be provided to all staff involved in transport, installation, operation, maintenance and repair.

The user manual may not be used for the purposes of competition without the written consent of E+E Elektronik® and may not be forwarded to third parties. Copies may be made for internal purposes. All information, technical data and diagrams included in the manual are based on the information available at the time of writing.

Disclaimer

The manufacturer or his authorized agent can only be held liable in case of willful or gross negligence. In any case, the scope of liability is limited to the corresponding amount of the order issued to the manufacturer. The manufacturer assumes no liability for damages incurred due to failure to comply with the applicable regulations, operating instructions or the operating conditions. Consequential damages are excluded from the liability.

1.2 Explanation of Symbols



This symbol indicates safety information.

It is essential that all safety information is strictly observed. Failure to comply with this information can lead to personal injuries or damage to property. E+E Elektronik® assumes no liability if this happens.



This symbol indicates instructions.

The instructions shall be observed in order to reach optimal performance of the device.



This symbol indicates ESD (electrostatic discharge) specific notes.

Non-observance can result in damage to the device.

1.3 Safety Instructions

1.3.1 General Safety Instructions



- Use the EE895 only as intended and observe all technical specs.
- This device is not appropriate for safety, emergency stop or other critical applications where device malfunction or failure could cause injury to human beings.

1.3.2 Intended Use

The EE895 miniature sensor module measures the CO₂ concentration, the temperature (T) and the absolute barometric pressure (p). It is intended to be used as sensor module in devices for diverse uses in non-condensing environments. Applications can be, e.g., in building automation, demand controlled ventilation and process control.

The sensor module can be mounted using several mounting methods. Please observe chapter 3 for mounting recommendations and descriptions. The use of the EE895 other than described in this manual is not recommended.

The manufacturer cannot be held responsible for damages as a result of incorrect handling, installation and maintenance of the device. Unauthorized modifications of the product lead to loss of all warranty claims. The device may only be powered with safety extra-low voltage (SELV).

1.4 Environmental Aspects



Products from E+E Elektronik® are developed and manufactured observing of all relevant requirements with respect to environment protection. Please observe local regulations for the device disposal.



The individual components of the device shall be disposed of according to local recycling regulations. The electronics shall be disposed of correctly as electronics waste.

1.5 Product Description

Beside CO₂ concentration up to 10 000 ppm, the EE895 measures temperature (T) and absolute barometric pressure (p). The active pressure and temperature compensation minimizes the impact of altitude and ambient conditions on the CO₂ measured data.

The CO₂, T and p measured data is available on I²C or UART digital interfaces. The solder pads, the plated half-holes and the through-holes allow for various mounting options.

1.6 Operating Principle CO₂ Measurement

The CO₂ measurement is based on the dual wavelength Non Dispersive Infra-Red (NDIR) technology which compensates for ageing effects, is highly insensitive to pollution and offers outstanding long term stability.

The infrared detector 1 (IR-1) is tuned to 4.2 µm, which is the wavelength absorbed by CO₂, the infrared detector 2 (IR-2) is tuned to 3.9 µm, which is not affected by any gas. For every single flash of the infrared lamp (IR-L), the device calculates the CO₂ concentration from the outputs of both infrared detectors IR-1 and IR-2. The measuring interval is user selectable (factory default: 15 s).

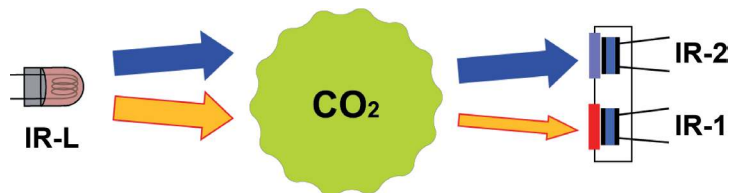

2 Handling Instructions



EE895 is an ESD sensitive device and must be handled with corresponding precautions. Protect the sensor outside the EPA (Electrostatic Protected Area) using ESD protective packaging.

The EE895 is packed in stacks of ESD trays with 50 pieces each. The tray dimension is 354.2 x 278.6 x 23.8 mm (13.94 x 10.97 x 0.94 inch).

Operating and storage conditions: -40...60 °C (-40...140 °F)
0...95 % RH (non-condensing)
700...1 100 mbar (10.15...15.95 psi)



The EE895 housing and the circuit board shall not be exposed to unnecessary mechanical stress during installation and operation. The forces exerted shall not exceed 50 N.

The sensor module deploys a fine dust filter for sensing element protection. If the EE895 is deployed in a device which is designed for harsh environments, the device shall deploy a filter as well.

3 Hardware

3.1 Dimensions

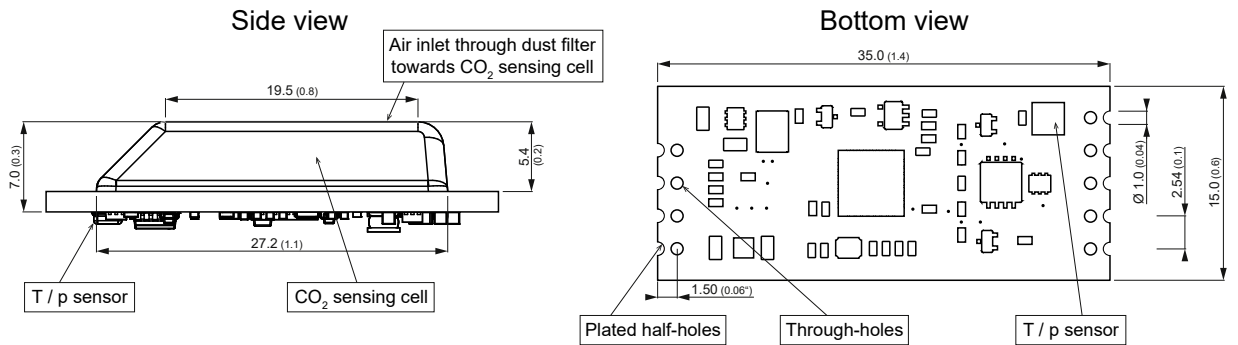

Fig. 1 Dimensions in mm (inch)

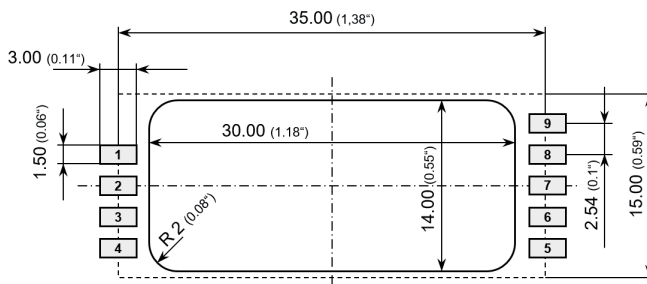

Fig. 2 Recommended PCB footprint

3.2 Mounting Recommendation



The EE895 is not intended for reflow soldering and consequently it does not feature a moisture sensitivity level rate (MSL). Nevertheless, for storage and handling it shall be regarded as compatible with MSL 1.



EE895 may only be soldered manually. A max. temperature of 360°C may be applied for max. 10 s per solder point.



ESD precautions shall be observed while manually soldering the EE895. The EE895 can be mounted facing either upwards or downwards.

3.2.1 Mounting via Solder Pads

The EE895 module can be mounted onto a pluggable female header or directly onto the electronics board by using a pin-header with 2.54 mm (0.1 inch) pitch.

The minimum clearance of 2 mm (0.08 inch) shall be strictly observed. This is necessary for free air flow around the CO₂ sensing cell and around the T/p sensor.

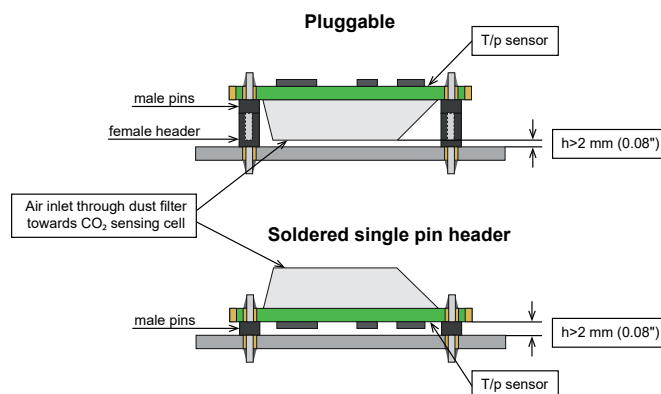

Fig. 3 Mounting with soldered pin header

3.2.2 Mounting via Side Plated Contacts

The EE895 can be mounted by manually soldering the plated half-holes onto the host board.

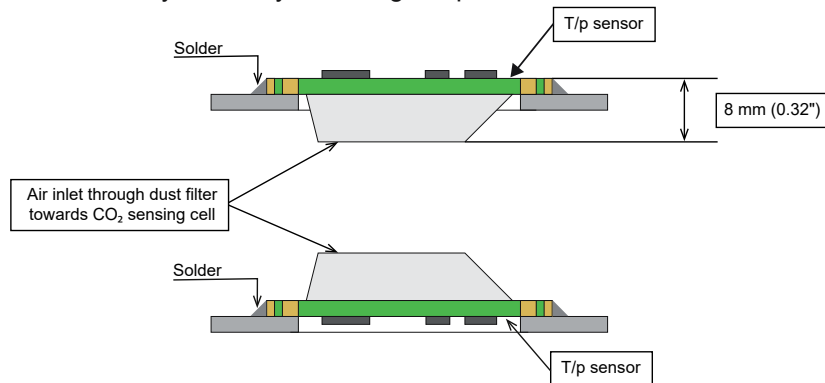

Fig. 4 Mounting by soldering at the side plated contacts

3.3 EE895 Block Diagram

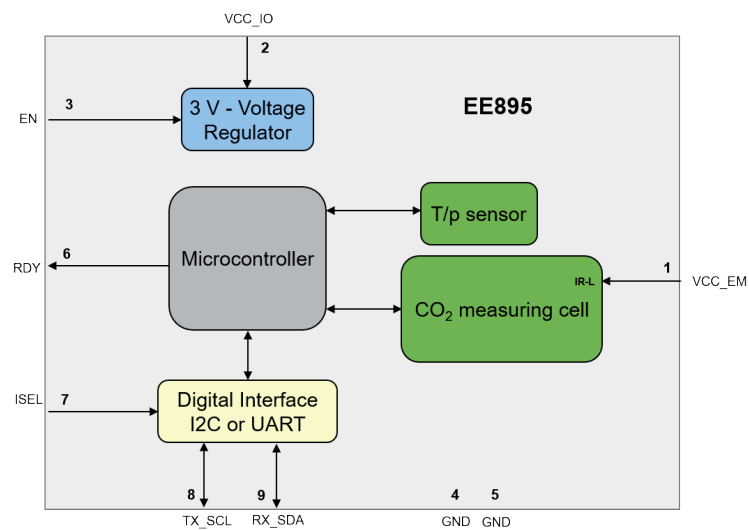

Fig. 5 Block diagram

3.4 Pin Assignment

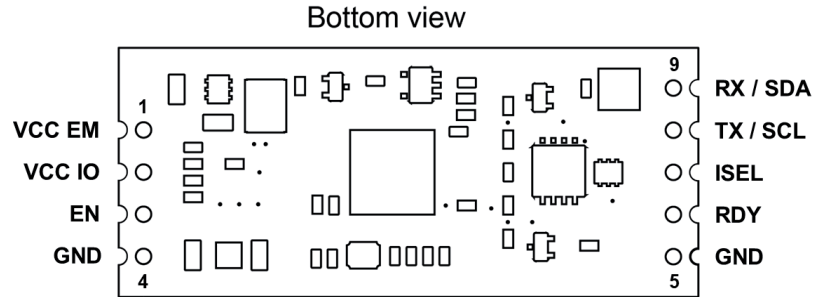

Fig. 6 Pin assignment

Pin	Name	Type	Comment
1	VCC_EM	Power supply	Power supply emitter infra-red lamp (IR-L)
2	VCC_IO	Power supply	Power supply for the microcontroller
3	EN	Input	Enable the module. Tie to Vcc_IO for normal operation
4	GND	Power supply	Ground ¹⁾
5	GND	Power supply	Ground ¹⁾
6	RDY	Output	Data ready (open drain output)
7	ISEL	Input	Interface selection
8	TX / SCL	I/O	Transmission line (TX) / Serial Clock (SCL)
9	RX / SDA	I/O	Receive line (RX) / Serial Data (SDA)

1) pins 4 and 5 shall be connected to the same potential

Tab. 1 Pin assignment

3.5 Pin Description

Pin 1 - VCC_EM

Power supply for the infrared lamp (IR-L). For optimizing of the energy consumption such as in battery-powered devices, the IR-L can be powered separately.

The IR-L does not have to be powered continuously, as it needs power supply during the measurement cycle t_{meas} only, see Fig. 7. Between the measurement cycles the current consumption of IR-L is approx. 0.1 μA .

Pin 2 - VCC_IO

Power supply for the microcontroller and the digital functional blocks.

Pin 3 – EN (Enable)

For battery-powered devices the user can optimize the energy consumption controlling the status of the EN pin by an external host controller.

When the EN pin is pulled-down to the logic Low ($\leq 0.4 V$), the internal voltage regulator of EE895 is switched off and the current consumption is typically 1 μA (max 2 μA).

When pulled-up to the logic state High ($\geq 0.9 V$), the EE895 operates normally.

If the energy consumption of EE895 is not relevant, the EN pin shall be connected to VCC_IO.

The EN pin may not be left open.

Pin 6 – RDY (Data ready)

During the measurement cycle (t_{meas}), when CO₂, T and p are measured and processed, the pin RDY is in logic state High. As soon as data is available for read out, the pin RDY goes to logic state Low. The falling edge at this pin indicates that measured data is available for reading, see Fig. 7.

If used, an external pull-up resistor is required. If not used, the RDY pin may be left open.

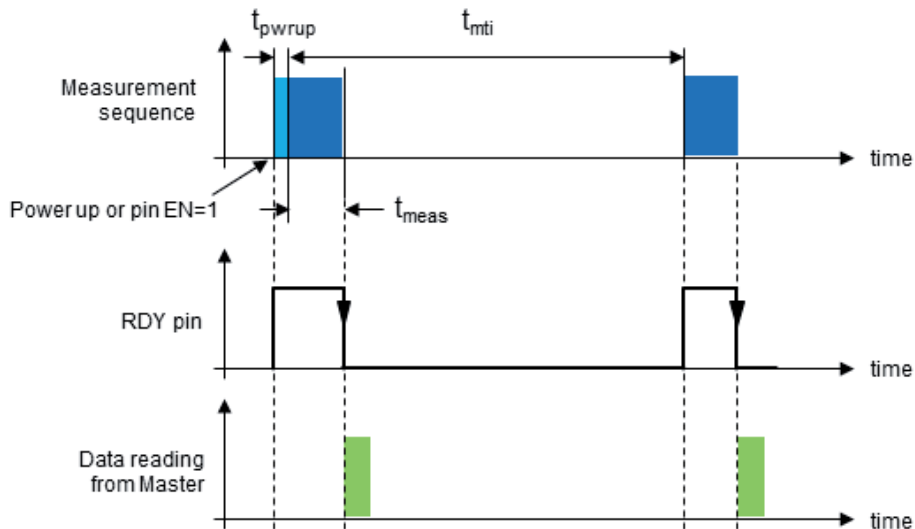

t_{pwrup}	power up time, approx. 150 ms
t_{meas}	measurement cycle (CO ₂ , RH, T,p) , approx. 300 ms warm-up + 300 ms IR lamp pulse
t_{mti}	measurement interval, user selectable 10...3600 s, +/-25 % (default: 15 s)

Fig. 7 Timing details (see chapter 4.5.3: "General Safety Instructions")

Pin 7 – ISEL (Interface selection)

The EE895 features I²C and UART interfaces.

Interface selection:

ISEL logic state	EE895 interface
Low (0...0.9 V)	I ² C
High (2.1...5.5 V) or not connected	UART

Tab. 2 Interface selection

Serial interface pins:

Pin 8 – TX_SCL Transmission data / Serial clock

Pin 9 – RX_SDA Receiving data / Serial data

The function of pins 8 and 9 depends on the interface selected with pin 7 ISEL:

Pin 7 – ISEL connected to ground: EE895 features I²C interface:

Pin	Mode	Note
8	SCL (serial clock)	External pull-up resistor to V+ (bus high voltage level) is required.
9	SDA (serial data)	External pull-up resistor to V+ (bus high voltage level) is required.

Tab. 3 Pin assignment I²C interface

Example:

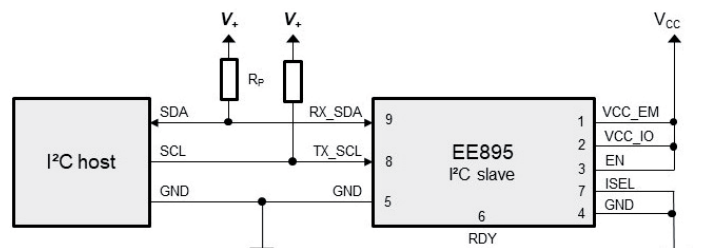

- V_{CC} = EE895 supply voltage: 3.3 – 5.5 V
- V₊ = Bus high voltage, typical 3.3 - 5.5 V
- R_p = I²C pull-up resistors, typical 10 kΩ
- V₊ and V_{CC} are independent but may be connected together
- Independently of V_{CC}, RX_SDA and TX_SCL pins are 5 V tolerant (max 5.5V)

Fig. 8 Example I²C interface

Pin 7 – ISEL connected to V_{CC} or left open: EE895 features UART interface:

Pin	Mode	Note
8	TX (transmission line)	CMOS compatible ($V_{OutLowMax}$ 0.4 V; $V_{OutHighMin}$ 2.6 V)
9	RX (receive line)	CMOS compatible ($V_{InputLowMax}$ 0.9 V; $V_{InputHighMin}$ 2.1 V)

Tab. 4 Pin assignement UART interface

Example:

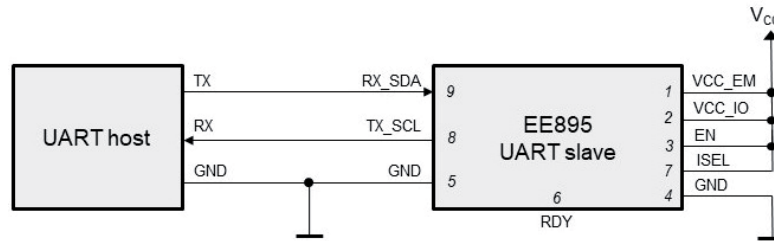

- V_{CC} = EE895 supply voltage: 3.3 – 5.5 V
- Independently of V_{CC}, RX_SDA pin is 5 V tolerant (5.5 V max)
- EE895 internal microcontroller uses 3 V supply
- RX_SDA/ TX_SCL pins are CMOS compatible:
 - RX_SDA $V_{InputLowMax}$ = 0.9 V; $V_{InputHighMin}$ = 2.1 V
 - TX_SCL $V_{OutLowMax}$ = 0.4 V; $V_{OutHighMin}$ = 2.6 V @ 8 mA

Fig. 9 Example UART interface

3.6 Electrical Characteristics

A DC/DC converter is used to flash the lamp (VCC_EM). Therefore, the supply current is reduced with higher voltage and vice versa. The microcontroller (VCC_IO) is supplied via a linear regulator, hence the supply current is constant.

The average current consumption at a sampling interval of 15 s (factory default) is 1.6 mA. Tab. 5 lists the typical and maximum current values in each individual state during the sampling interval, which is shown in the current profile in Fig. 10.

Status	Power Supply	VCC_IO	VCC_EM	
			3.3 V	5 V
Idle measurement		5.2 (7.9) mA	< 0.1 μ A	< 0.1 μ A
IR lamp pulse		5.2 (7.9) mA	93 (95) mA	60 (61) mA
Standby		170 (200) μ A	< 0.1 μ A	< 0.1 μ A
Power off		< 2 μ A	< 0.1 μ A	< 0.1 μ A

Tab. 5 Current values in the individual measurement states, typ. (max.)

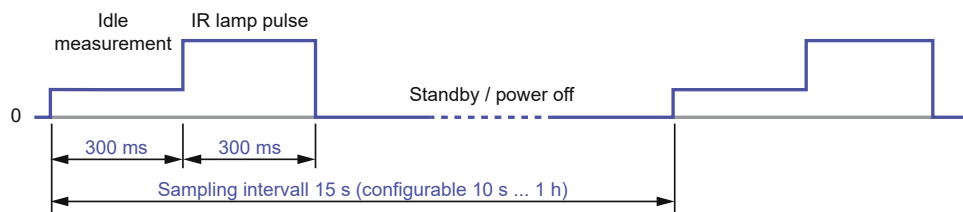

Fig. 10 States during a CO₂ sampling interval

Further electrical characteristics:

Signal	Unit	Min	Max	Note
Clock frequency	Hz	500	100000	
Pull-up resistor	k Ω	4.7	100	Typical 10 k Ω

Tab. 6 Electrical characteristics

3.7 Typical Applications

3.7.1 EE895 Connected to USB Interface

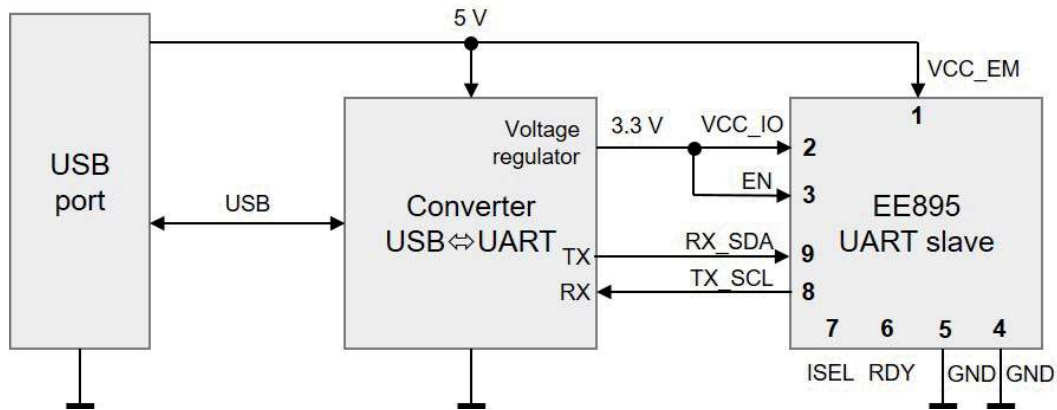

Fig. 11 Example USB Interface

Pin 7 - ISEL is not connected → the EE895 features UART interface.

VCC_EM is connected to the nominal 5 V from USB, the VCC_IO and EN are connected to 3.3 V voltage regulator.

The host can read the values at any time, pin 6 - RDY is not used.

3.7.2 EE895 in Battery Powered Devices

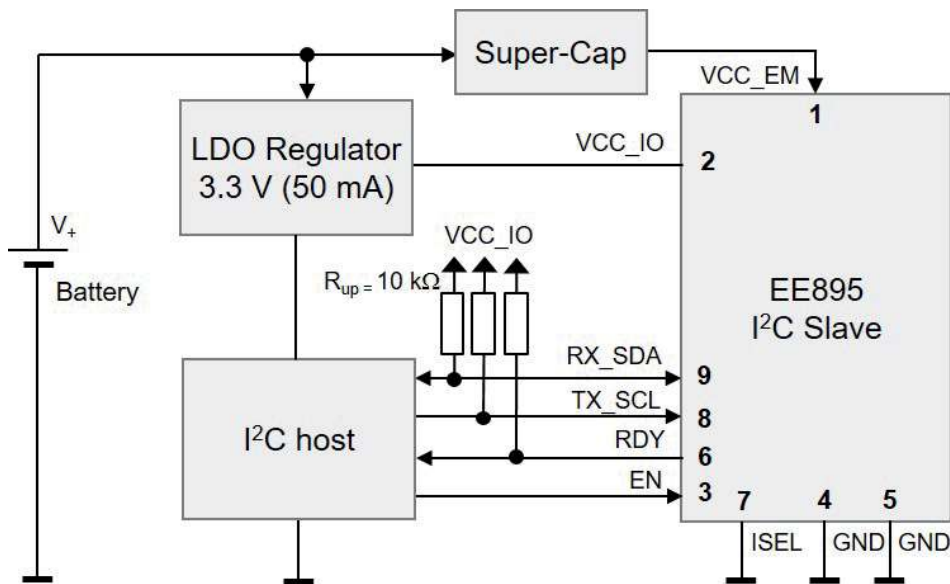

Fig. 12 Example battery powered devices

Pin 7 - ISEL is connected to the ground → the EE895 features I²C interface.

VCC_EM is supplied by a low ESR super-capacitor and VCC_IO is connected to a typical low drop 3.3 V regulator.

The I²C host enables the EE895 with pin 3 - EN.

By checking the status of pin 6 - RDY (pulled up), the host can read the data as soon as available. After reading the data, EE895 can be disabled with pin 3.

3.7.3 EE895 Connected to a KNX Bus

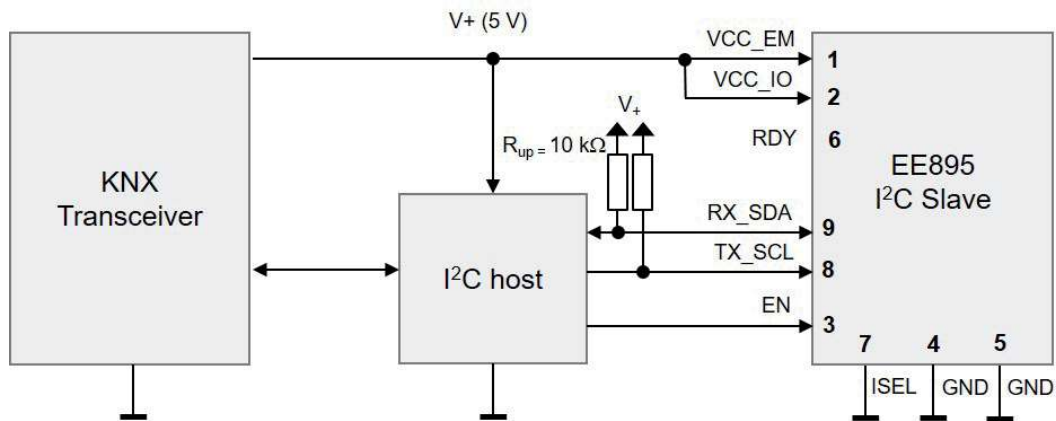

Fig. 13 Example KNX Bus

Pin 7 - ISEL is connected to the ground → the EE895 features I²C interface.
 The VCC_EM and the VCC_IO are connected to the typical 5 V bus voltage.
 The I²C host keeps the EE895 enabled with the pin 3 – EN and can read the values at any time, pin 6 - RDY is not used.

4 Digital Interface

The EE895 features standard I²C and UART interfaces.
 The interface selection is made with pin 7 – ISEL, see Tab. 2 on page 9.
 On both interfaces, I²C and UART, the data is encapsulated in Modbus Protocol Data Units (Modbus PDUs).



Please note: Modbus implementation details and request/response examples are described in detail in the Modbus Application Note AN0103 (available at www.epluse.com/EE895).

4.1 I²C Interface

The EE895 supports the standard I²C specification. For detailed information about the I²C interface, please refer to NXP document „I²C-bus specification and user manual“, Rev. 6, 4 April 2014: www.nxp.com/docs/en/user-guide/UM10204.pdf

The I²C interface simultaneously supports two protocols on two different slave addresses:

- Modbus over I²C address 0x5F
- I²C simplified address 0x5E

These addresses are fixed, they cannot be changed by the user.

4.1.1 Modbus Protocol Over I²C Interface

I²C slave address: 0x5F

The I²C interface encapsulates the data according Modbus PDU packets, including CRC:

S	Slave Address	W	A	Request: Modbus PDU + Modbus CRC	P
S	Slave Address	R	A	Response: Modbus PDU + Modbus CRC	P

Every byte of the Modbus PDU and the Modbus CRC must be acknowledged (according to I²C specification, not shown above).

The EE895 module supports repeated START or STOP conditions between the request packet and the response packet. If a START condition and an address match are detected, the EE895 will stay active until a STOP condition is received or an idle timeout of 500 ms occurs. This might increase the power consumption and self-heating. The I²C master shall ensure that the data is retrieved as soon as possible in case of a repeated START.

For the Modbus register map please refer to chapter 4.3, page 15.



Please note: The CRC16 shall be calculated including the unshifted slave address.

Example of command reading the temperature (floating point value) T = 25.30 °C from the register 0x3EA:

Request [Hex]: S BE 03 03 EA 00 02 E8 C5 P

START	Slave address 7-bit shifted	Function code	Starting address Hi	Starting address Lo	No. of register Hi	No. of register Lo	CRC		STOP
S	BE	03	03	EA	00	02	E8	C5	P

Response [Hex]: S BF 03 04 00 00 41 DC 74 3F P

START	Slave address 7-bit shifted	Function code	Byte count	Register 1 value Hi	Register 1 value Lo	Register 2 value Hi	Register 2 value Lo	CRC		STOP
S	BF	03	04	00	00	41	DC	74	3F	P

For decoding of float values stored according standard IEEE 754, please refer also to the Modbus Application Note AN0103.

Example of Decoding:

Response [Hex]:

Byte 1 (Register 2 - Hi)	Byte 2 (Register 2 - Lo)	Byte 3 (Register 1 - Hi)	Byte 4 (Register 1 - Lo)	Decimal value
41	DC	00	00	27.50



Please note: For obtaining the correct value, both registers have to be read with a single request. The measured value can change between two Modbus requests. Exponent and mantissa may get inconsistent in this case.

4.1.2 I²C Simplified Protocol

I²C slave address: 0x5E

This I²C protocol is intended for I²C master reading the measured values from EE895 in “EEPROM-like-mode”.

The simplified I²C does not support any error detection (such as CRC) and provides the measured data in 8 subsequent registers, as 16 bit integers.

Slave address	0x00	0x01	0x02	0x03	0x04	0x05	0x06	0x07
0x5E	CO ₂ high byte	CO ₂ low byte	T high byte	T low byte	reserved*) high byte	reserved*) low byte	p high byte	p low byte

*) Reserved for future use

The read pointer is the first register to be set. Additional bytes are answered by the EE895 module with NACK. If more bytes are read than the 8 registers, the EE895 answers with 0xFF (i.e. the SDA line is not pulled down). If a START condition and an address match are detected, the EE895 will stay active until a STOP condition is received or an idle timeout of 500 ms occurs.

The measured data is available as a 16 bit integer and is expressed in SI units:

Measurand	Register pointer	Unit	Scale
CO ₂ average, pc ¹⁾	0x00	ppm	1:1
T	0x02	°C	1:100 *
p	0x06	mbar	1:10 **
CO ₂ average, npc ²⁾	0x08	ppm	1:1
CO ₂ raw, pc ¹⁾	0x0A	ppm	1:1
CO ₂ raw, npc ²⁾	0x0C	ppm	1:1

* Example: 2575 means 25.75 °C

** Example: 10130 means 1013 mbar

1) pc ... pressure compensated

2) npc ... not pressure compensated

Tab. 7 Data availability from the EE895 Miniature Sensor Module

Example for reading all measurands (7-bit address shifted):

Request [Hex]: S BC 00 P

START	Slave address 7-bit shifted	Register pointer	STOP
S	BC	00	P

Response [Hex]: S BD 03 B0 0A B7 8D 00 26 70 P

START	Slave address 7-bit shifted	CO ₂ high byte	CO ₂ low byte	T high byte	T low byte	res.*) high byte	res.*) low byte	p high byte	p low byte	STOP
S	BD	03	B0	0A	B7	80	00	26	70	P

*) reserved for future use

Conversion:

Measurand	Response [Hex]	Response [Dec]	Value
CO ₂	0x03B0	944	944 ppm
T	0x0AB7	2743	27.43 °C
p	0x2670	9840	984.0 mbar

Tab. 8 Interpretation of data from the response

Example for reading the air pressure value (7-bit address shifted):

Request [Hex]: S BC 06 P

START	Slave address 7-bit shifted	Register pointer	STOP
S	BC	06	P

Response [Hex]: S BD 26 70 P

START	Slave address 7-bit shifted	p high byte	p low byte	STOP
S	BD	26	70	P

Conversion:

Measurand	Response [Hex]	Response [Dec]	Value
p	0x2670	9840	984.0 mbar

Tab. 9 Interpretation of data from the response

4.2 UART Interface

4.2.1 Modbus Protocol Over UART Interface

Modbus slave address: 0x5F

The interface settings are: Baud rate 9600, 8 Data, No parity, 1 Stop bit (9600 8 N 1)

The slave address and the interface settings are fixed, they cannot be changed by the user.

The EE895 module shall be addressed according to the specification “Modbus over serial line V1.02”, see http://www.modbus.org/docs/Modbus_over_serial_line_V1_02.pdf.

Modbus frame description (screenshot taken from the “Modbus over Serial Line Specification and Implementation Guide V1.02” mentioned above):

The MODBUS application protocol [1] defines a simple **Protocol Data Unit (PDU)** independent of the underlying communication layers:

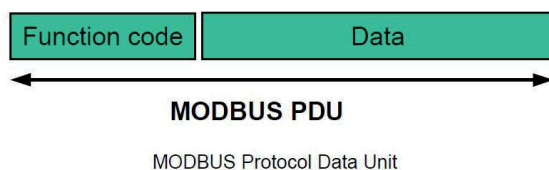

The mapping of MODBUS protocol on a specific bus or network introduces some additional fields on the **Protocol Data Unit**. The client that initiates a MODBUS transaction builds the MODBUS PDU, and then adds fields in order to build the appropriate communication PDU.

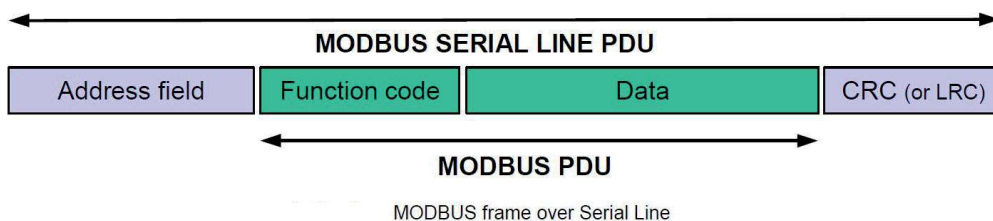

4.3 Modbus Register Map

Following Modbus register map is valid for both, the I²C and the UART interface. The measured data is saved as 32 bit floating point values (data type FLOAT) and as 16 bit signed integer values (data type INTEGER), please refer to Tab. 10 and Tab. 11 below:

FLOAT 32 bit			
Parameter	Unit	Register number ¹⁾ [DEC]	Register address ²⁾ [HEX]
<i>Read register: function code 0x03</i>			
Temperature T	° C	1003	0x3EA
Temperature T	° F	1005	0x3EC
Temperature T	K	1009	0x3F0
CO ₂ (average), pc ³⁾	ppm	1061	0x424
CO ₂ (raw), pc ³⁾	ppm	1063	0x426
CO ₂ (average), npc ⁴⁾	ppm	1065	0x428
CO ₂ (raw), npc ⁴⁾	ppm	1067	0x42A
Pressure p	mbar	1201	0x4B0
Pressure p	psi	1203	0x4B2

1) Register number starts from 1

2) Register address starts from 0

3) pc ... pressure compensated

4) npc ... not pressure compensated

Tab. 10 I²C and UART Modbus register map for 32 bit floating point values

INTEGER 16 bit				
Parameter	Unit	Scale ³⁾	Register number ¹⁾ [DEC]	Register address ²⁾ [HEX]
Read register: function code 0x03				
Temperature T	° C	100	4002	0xFA1
Temperature T	° F	50	4003	0xFA2
Temperature T	K	50	4005	0xFA4
CO ₂ (average), pc ⁴⁾	ppm	1	4031	0xFBE
CO ₂ (raw), pc ⁴⁾	ppm	1	4032	0xFBF
CO ₂ (average), npc ⁵⁾	ppm	1	4033	0xFC0
CO ₂ (raw), npc ⁵⁾	ppm	1	4034	0xFC1
Pressure p	mbar	10	4101	0x1004
Pressure p	psi	100	4102	0x1005

1) Register number starts from 1

2) Register address starts from 0

3) Examples: For scale 100, the reading of 2550 means a value of 25.5. For scale 50, the reading of 2550 means a value of 51.

4) pc ... pressure compensated

5) npc ... not pressure compensated

Tab. 11 I²C and UART Modbus register map for 16 bit signed integer values

4.4 General Purpose Registers for Individual Use

There are two registers reserved for any customer use, e.g. serial number, traceability, etc.

Register number ¹⁾ [DEC]	Register address ²⁾ [HEX]	Space (standard Modbus register)
Write register: function code 0x06 / Read register: function code 0x03		
5801	0x16A8	16 bits / 2x8 bits / 2 bytes
5802	0x16A9	16 bits / 2x8 bits / 2 bytes

1) Register number starts from 1

2) Register address starts from 0

Tab. 12 Registers for special customer purpose

4.5 EE895 Commands

The following commands are available via Modbus over I²C and Modbus over UART.



Please note: I²C simplified does not support Modbus encapsulation. Therefore, no Modbus communication and no settings are possible.

4.5.1 Information

Function code	Register address ¹⁾ [Hex]	Description	Note
0x03	0x00	Serial number	EE895 serial number, ASCII, 0 terminated
	0x08	FW-Version (Major, Minor)	High-Byte = Major Version Low-Byte = Minor Version Example: 0x011A = 1.26 [01=1; 1A=26]
	0x09	Sensor name	2 ASCII characters for each Register ("EE895") String is 0-terminated

1) Register address starts from 0

Tab. 13 Available commands for I²C and UART



Please note: When reading the serial number or the sensor name, it is always necessary to read all 8 registers, even if the desired information requires less.

4.5.2 General Settings

The following functions allow for EE895 settings. These are stored in the RAM, therefore they are volatile.

Measuring mode: continuous or single shot

Function code	Register address ¹⁾ [Hex]	Note
Read 0x03 Write 0x06	0x1F8	[Bit 0] Default status = 0 0 = continuous. The EE895 measures at the regular interval set with the command "CO ₂ measuring interval", see chapter 4.5.3. 1 = single shot. The EE895 measures only with the command "Measuring trigger", see below. [Bit 1..15] reserved (must be written as 0)

1) Register address starts from 0

Tab. 14 Continuous or single shot measurement

Measuring status: indicates when new single shot measurement is possible.

Function code	Register address ¹⁾ [Hex]	Note
0x03	0x1F9	[Bit 0]: Data ready. The data are available for read out. 0 = busy, 1 = ready [Bit 1]: Trigger ready. The EE895 is ready for new measurement cycle. The minimum time interval between two triggers is 10 s. 0 = trigger not possible 1 = ready for new trigger [Bit 2..15] reserved (do not use)

1) Register address starts from 0

Tab. 15 Single shot measurement possible

Measuring trigger: command for the single shot measurement. For accurate measurement results, there are recommended six single shot measurements under stable temperature conditions.

Function code	Register address ¹⁾ [Hex]	Note
0x06	0x1FA	[Bit 0]: Measurement Trigger 0 = don't care 1 = Start new measurement cycle [Bit 1..15] reserved (must be written as 0)

1) Register address starts from 0

Tab. 16 Command single shot measurement

EE895 detailed status

Function code	Register address ¹⁾ [Hex]	Note
0x03	0x258	[Bit 0]: CO ₂ measurement too high [Bit 1]: CO ₂ measurement too low [Bit 2]: T measurement too high [Bit 3]: T measurement too low [Bit 6]: p measurement too high [Bit 7]: p measurement too low [Bit 8...15]: reserved (do not use)

1) Register address starts from 0

Tab. 17 Status details

4.5.3 CO₂ Parameter Settings

The CO₂ parameter settings are non-volatile since they are stored in the flash memory.

Function code	Register address ¹⁾ [Hex]	Description	Unit	Note
0x06	0x1450	CO ₂ measuring interval	s	16 bit integer unsigned Scale 1:10. Example: 150 = 15 seconds Range 100...36 000 Default 15 s
	0x1451	CO ₂ filter coefficient ^{*)}	-	16 bit integer unsigned Range 1...20 Default: 4
	0x1452	CO ₂ customer offset	ppm	16 bit integer signed Range -32 786...32 785 Default: 0 ppm

1) Register address starts from 0

Tab. 18 CO₂ parameter settings

*) The EE895 features an exponential moving average filter which to a certain degree suppresses the influence of short-term CO₂ variations onto the output CO₂ data. The filter coefficient is user selectable and affects the response time of the EE895. A higher filter coefficient leads to smoother output data and to longer response time, see figure Fig. 14. Fig. 15 shows the number of samples required to reach 63% or 90% of a CO₂ step as function of the filter coefficient.

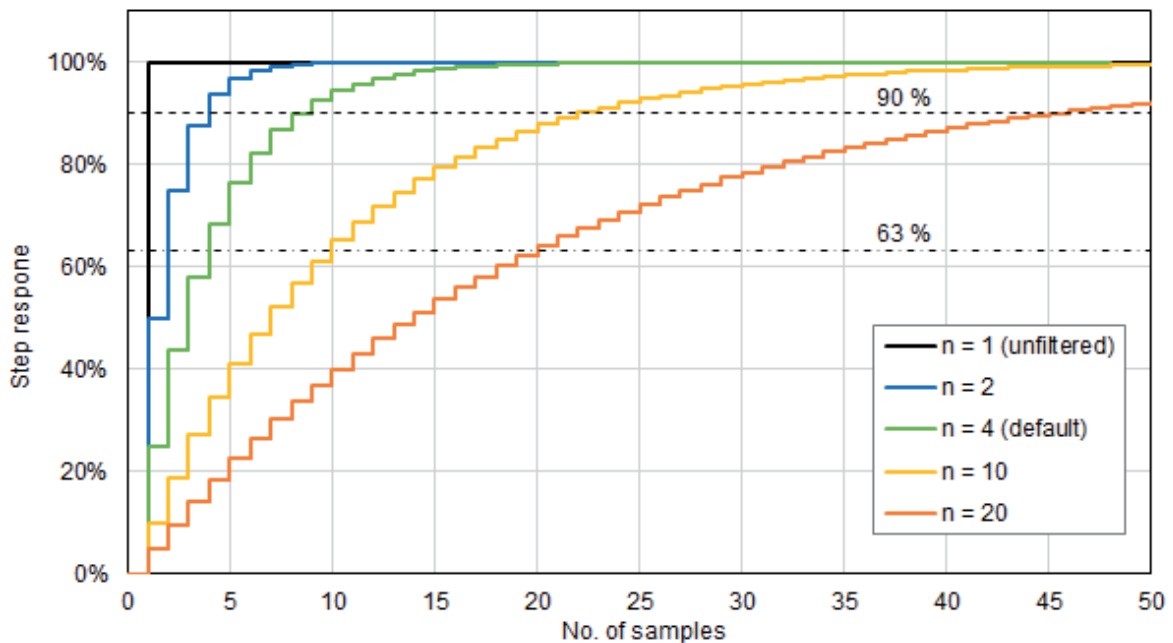

Fig. 14 Step response vs. samples

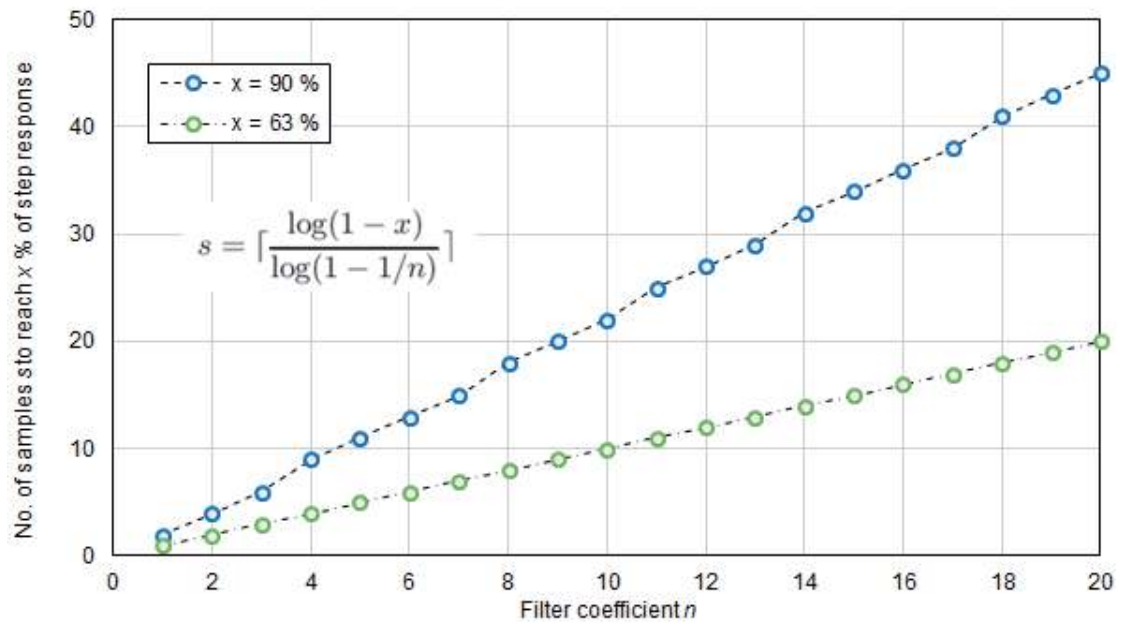

Fig. 15 Step response vs. filter coefficient

5 Technical Data

Measurands

CO₂	
Measurement principle	Dual wavelength NDIR (non-dispersive infrared technology)
Working range	0...2000 / 5000 / 10000 ppm
Accuracy at 25 °C and 1013 mbar ¹⁾ (77 °F and 14.69 psi)	0...2000 ppm < ± (50 ppm + 2 % of the measured value) 0...5000 ppm < ± (50 ppm + 3 % of the measured value) 0...10000 ppm < ± (100 ppm + 5 % of the measured value)
T and p compensation of the CO ₂ reading	With on-board sensors
Initialisation time (power on)	< 1 s
Response time t ₆₃	140 s with measured data averaging (smooth output) 75 s without measured data averaging
Temperature dependency, typ.	± (1 + CO ₂ concentration [ppm] / 1000) ppm/°C (-20...45 °C) (-4...113 °F)
Residual pressure dependency ²⁾ , typ.	± 0.014 % of the measured value / mbar (ref. to 1013 mbar)
Calibration interval ³⁾	5 years
Sampling interval	User configurable from 10 s up to 1 h; factory setup = 15 s
Pressure	
Working range	700...1100 mbar (10.15...15.95 psi)
Accuracy at 25 °C (77 °F), typ.	± 2 mbar (20...80 % RH)
Temperature dependency	± 0.015 mbar/K
Temperature	
Working range	-40...60 °C (-40...140 °F)
Accuracy at 25 °C (77 °F), typ.	± 0.5 °C (± 0.9 °F)

General

Digital interface (pin-selectable)	
I ² C	Up to 100 kbit/s
UART	9600 Baud, 8 bits, no parity, 1 stop bit
Module control	
Enable pin	Continuous operation / power down
Data ready pin	Indication of valid data
Supply voltage	3.3 - 5 V DC ± 5 %
Average current consumption for supply voltage 5 V, typ.	1.6 mA at 15 s sampling interval 177 µA at 1 h sampling interval with standby between measurements 7 µA at 1h sampling interval with power down between measurements
Current profile for supply voltage 5 V, typical values	
Electrical connection	Side plated contacts and solder pads, Ø 1 mm (0.04")
Working and storage conditions	-40...60 °C (-40...140 °F) 0...95 % RH (non-condensing) 700...1100 mbar (10...16 psi)

1) With data averaging for smooth output signal. Operation without measured data averaging or in short-time mode might lead to additional measurement uncertainty.

2) The pressure dependency of a device without pressure compensation: 0.14 % of measured value / mbar.

3) Recommended under normal operating conditions in building automation.



HEADQUARTERS

E+E Elektronik Ges.m.b.H.

Langwiesen 7
4209 Engerwitzdorf
Austria
Tel.: +43 7235 605-0
E-mail: info@epluse.com
Web: www.epluse.com

SUBSIDIARIES

E+E Elektronik China

18F, Kaidi Financial Building,
No.1088 XiangYin Road
200433 Shanghai
Tel.: +86 21 6117 6129
E-mail: info@epluse.cn

E+E Elektronik France

Le Norly III, 136 chemin du Moulin
69130 Ecully
Tel.: +33 4 74 72 35 82
E-mail: info@epluse.fr

E+E Elektronik Germany

Schöne Aussicht 8 C
61348 Bad Homburg
Tel.: +49 6172 13881-0
E-mail: info@epluse.de

E+E Elektronik Italy

Via Alghero 17/19
20128 Milano (MI)
Tel.: +39 02 2707 86 36
E-mail: info@epluse.it

E+E Elektronik Korea

Suite 2001, Heungdeok IT
Valley Towerdong, 13,
Heungdeok 1-ro, Giheung-gu
16954 Yongin-si, Gyeonggi-do
Tel.: +82 31 732 6050
E-mail: info@epluse.co.kr

E+E Elektronik USA

333 East State Parkway
Schaumburg, IL 60173
Tel.: +1 847 490 0520
E-mail: office@epluse.com

YOUR PARTNER IN SENSOR TECHNOLOGY



ELEKTRONIK®
Ges.m.b.H.