

NPN COMPLEMENTARY SILICON PLANAR EPITAXIAL TRANSISTORS

**BCY58, BCY59
TO-18**

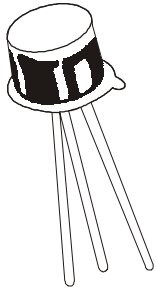

Low Noise Audio Amplifier Input Stages & Driver Applications

Complementary BCY78/79

ABSOLUTE MAXIMUM RATINGS

DESCRIPTION	SYMBOL	BCY58	BCY59	UNITS
Collector -Emitter Voltage	VCEO	32	45	V
Collector -Emitter Voltage(RBE=10 ohms)	VCES	32	45	V
Emitter -Base Voltage	VEBO		7.0	V
Collector Current Continuous	IC		0.2	A
Power Dissipation@ Ta=25 degC	PD		0.6	W
Derate Above 25 deg C			2.28	mW/deg C
Power Dissipation@ Tc=25 degC	PD		1.0	W
Derate Above 25 deg C			6.67	mW/deg C
Operating And Storage Junction Temperature Range	Tj, Tstg		-65 to +200	deg C
THERMAL RESISTANCE				
Junction to Case	Rth(j-c)		150	deg C/W
Junction to Ambient	Rth(j-a)		450	deg C/W

ELECTRICAL CHARACTERISTICS (Ta=25 deg C Unless Otherwise Specified)

DESCRIPTION	SYMBOL	TEST CONDITION	BCY58	BCY59	UNITS
Collector -Emitter Voltage	VCEO	IC=10mA, IB=0	>32	>45	V
Emitter-Base Voltage	VEBO	IE=1uA, IC=0	>7.0	>7.0	V
Collector-Cut off Current	ICES	VCE=32V, VBE=0	<10	-	nA
		VCE=45V, VBE=0	-	<10	nA
		Ta=150deg C			
		VCE=32V, VBE=0	<10	-	uA
Emitter-Cut off Current	IEBO	VCE=45V, VBE=0	-	<10	uA
		Ta=100deg C			
		VCE=32V, VBE=0.2V	<20	-	uA
DC Current Gain	hFE	VCE=5V, IC=0	All	<10	nA
		IC=10uA, VCE=5V			
		BCY58-7/59-7		-	
		BCY58-8/59-8		>20	
		BCY58-9/59-9		>40	
		BCY58-10/59-10		>100	
		IC=2mA, VCE=5V			
		BCY58-7/59-7		120-220	
		BCY58-8/59-8		180-310	
		BCY58-9/59-9		250-460	
		BCY58-10/59-10		380-630	

ELECTRICAL CHARACTERISTICS (Ta=25 deg C Unless Otherwise Specified)
BCY58/59

DESCRIPTION	SYMBOL	TEST CONDITION	VALUE	UNITS			
DC Current Gain	hFE	IC=10mA, VCE=1V	BCY58-7/59-7	>80			
			BCY58-8/59-8	120 to 400			
			BCY58-9/59-9	160 to 630			
			BCY58-10/59-10	240 to 1000			
				IC=100mA, VCE=1V	BCY58-7/59-7	>40	
					BCY58-8/59-8	>45	
					BCY58-9/59-9	>60	
					BCY58-10/59-10	>60	
Collector -Emitter Saturation Voltage	VCE(Sat)	IC=10mA, IB=0.25mA	0.05 to 0.35	V			
		IC=100mA, IB=2.5mA	0.15 to 0.70	V			
Base -Emitter Saturation Voltage	VBE(Sat)	IC=10mA, IB=0.25mA	0.60 to 0.85	V			
		IC=100mA, IB=2.5mA	0.75 to 1.2	V			
Base Emitter on Voltage	VBE(on)	IC=2mA, VCE=5V	0.55 to 0.70	V			
<u>DYNAMIC CHARACTERISTICS</u>							
Current Gain-Bandwidth Product	ft	IC=10mA, VCE=5V, f=100MHz	>125	MHz			
Output- Capacitance	Cob	VCB=10V, f=1MHz	<6.0	pF			
Input- Capacitance	Cib	VBE=0.5V, f=1MHz	<15	pF			
Small Signal Current Gain	hfe	ALL f=1kHz IC=2mA, VCE=5V	BCY58-7/59-7	125 to 250			
			BCY58-8/59-8	175 to 350			
			BCY58-9/59-9	250 to 500			
			BCY58-10/59-10	350 to 700			
Out put Admlttance	hoe	IC=2mA, VCE=5V	BCY58-7/59-7	<30	umhos		
			BCY58-8/59-8	<50			
			BCY58-9/59-9	<60			
			BCY58-10/59-10	<100			
Input Impedance	hie	IC=2mA, VCE=5V	BCY58-7/59-7	1.6 to 4.5	kohms		
			BCY58-8/59-8	2.5 to 6.0			
			BCY58-9/59-9	3.2 to 8.5			
			BCY58-10/59-10	4.5-12			
Voltage Feedback Ratio	hre	IC=2mA, VCE=5V	BCY58-7/59-7	Typ1.5	X10-4		
			BCY58-8/59-8	Typ 2.0			
			BCY58-9/59-9	Typ 2.0			
			BCY58-10/59-10	Typ 3.0			

ELECTRICAL CHARACTERISTICS (Ta=25 deg C Unless Otherwise Specified)

BCY58/59

DESCRIPTION	SYMBOL	TEST CONDITION	VALUE	UNITS
Noise Figure	NF	IC=0.2mA, VCE=5V Rs=2 kohms, f=1kHz	<6.0	dB
SWITCHING TIME				
Delay time	td		Typ35	ns
Rise time	tr	IC=10mA, IB1=1mA,	Typ50	
Turn on time	ton	IB2=1mA, VBB=3.6V	<150	
Storage time	ts	R1=R2=5 kohms	Typ400	
Fall time	tf	RL=990 ohms	Typ80	
Turn off time	toff		<800	
Delay time	td		Typ5.0	ns
Rise time	tr	IC=100mA, IB1=10mA,	Typ50	
Turn on time	ton	IB2=10mA, VBB=5V,	<150	
Storage time	ts	R1=500 ohms,	Typ250	
Fall time	tf	R2=700 ohms	Typ200	
Turn off time	toff	RL=98 ohms	<800	

TO-18 Metal Can Package

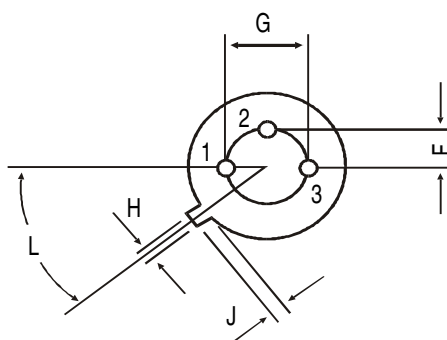
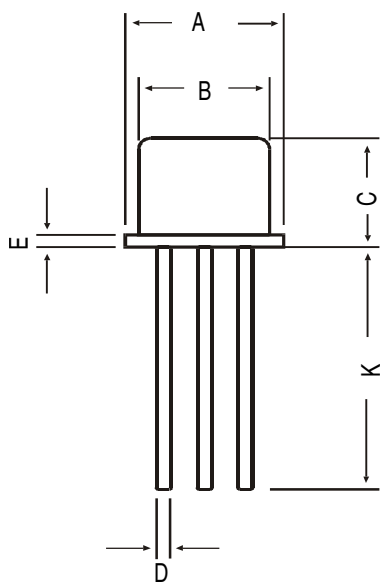

All dimensions in mm.

DIM	MIN	MAX
A	5.24	5.84
B	4.52	4.97
C	4.31	5.33
D	0.40	0.53
E	—	0.76
F	—	1.27
G	—	2.97
H	0.91	1.17
J	0.71	1.21
K	12.70	—
L	45 DEG	

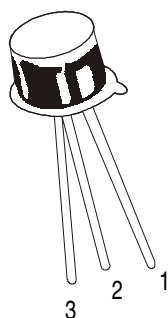

PIN CONFIGURATION

1. EMITTER
2. BASE
3. COLLECTOR

Packing Detail

PACKAGE	STANDARD PACK		INNER CARTON BOX		OUTER CARTON BOX		
	Details	Net Weight/Qty	Size	Qty	Size	Qty	Gr Wt
TO-18	1K/polybag	350 gm/1K pcs	3" x 7.5" x 7.5"	5.0K	17" x 15" x 13.5"	80.0K	34 kgs

Notes

Disclaimer

The product information and the selection guides facilitate selection of the CDIL's Discrete Semiconductor Device(s) best suited for application in your product(s) as per your requirement. It is recommended that you completely review our Data Sheet(s) so as to confirm that the Device(s) meet functionality parameters for your application. The information furnished on the CDIL Web Site/CD is believed to be accurate and reliable. CDIL however, does not assume responsibility for inaccuracies or incomplete information. Furthermore, CDIL does not assume liability whatsoever, arising out of the application or use of any CDIL product; neither does it convey any license under its patent rights nor rights of others. These products are not designed for use in life saving/support appliances or systems. CDIL customers selling these products (either as individual Discrete Semiconductor Devices or incorporated in their end products), in any life saving/support appliances or systems or applications do so at their own risk and CDIL will not be responsible for any damages resulting from such sale(s).

CDIL strives for continuous improvement and reserves the right to change the specifications of its products without prior notice.



CDIL is a registered Trademark of

Continental Device India Limited

C-120 Naraina Industrial Area, New Delhi 110 028, India.

Telephone + 91-11-579 6150 Fax + 91-11-579 9569, 579 5290

e-mail sales@cdil.com www.cdil.com