

REVISION RECORD			
REV	ECN	DESCRIPTION	DRFT DATE

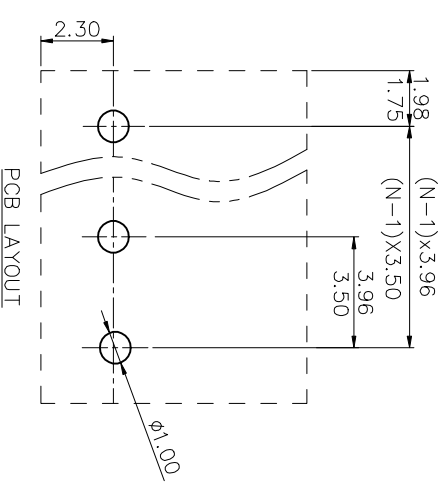
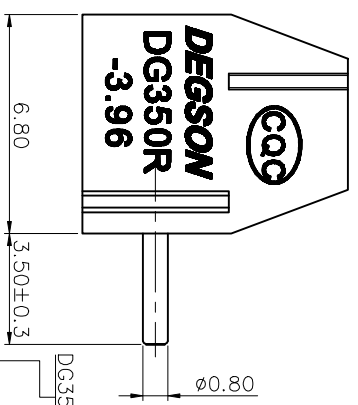
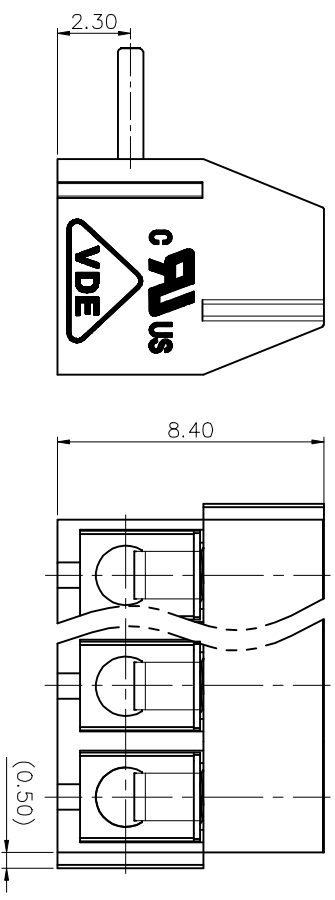
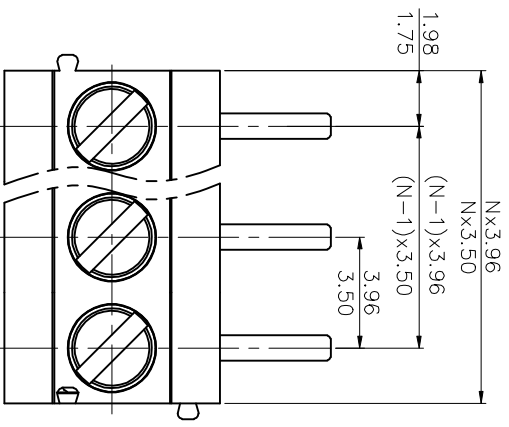

NOTES1:

- UL Standard
- 1. Rated Voltage/Current : 300V / 7A
- 2. Torque Value : M2 , 1.77Lb.in
- 3. Wire Range : 24~18AWG

IEC Standard

- 1. Rated Voltage/Current : 130V / 10A
- 2. Torque Value : M2 , 0.2N.m
- 3. Wire Range : 0.5~1.0mm<sup>2</sup>

NOTES2:

- 1. Dimension shall be interpreted per ASME Y14.5-2009
- 2. Pitch : 3.96/3.5mm, Poles : N=02~24P
- 3. Stripping length : 5mm
- 4. Withstanding Voltage : AC1250V/1Min.
- 5. Operating temperature: -40°C~+105°C
- 6. Undimensioned Tolerances:

Pitch Range in mm		Nominal Dimension Range in mm		Tolerance	
Over	Under	Over	Under	Over	Under
6	10	30	60	100	150
TO	TO	TO	TO	TO	TO
6	10	24	30	60	100
±0.15	±0.20	±0.30	±0.30	±0.50	±1.00
±1.00	±1.30	±1.00	±1.30	±1.30	±2.0

7. RoHS Compliance

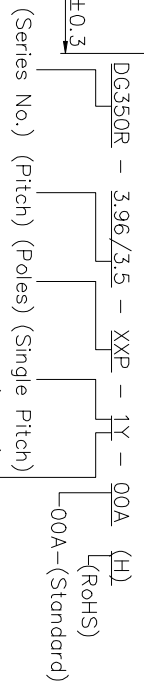

- 1. (Grey)
- 2. (Blue)
- 3. (Black)
- 4. (Green)
- 5. (Orange)
- 6. (Red)
- 7. (Transparent)
- 8. (Yellow)
- 9. (White)

DETACHED LISTS	
PART NO.:	/
APPD:	/
CHKD:	/
DRFT:	/
THIRD ANGLE PROJECTION	
NAME:	<b>DEGSON®</b> 宁波德森电子有限公司 NINGBO DEGSON ELECTRICAL CO., LTD
TITLE:	CUSTOMER DRAWING
DRAWING NO.:	/
REV	DO
SHEET	1/1
SCALE	1:1