

尺寸标注及检具说明：尺寸标有以下符号的尺寸为重点尺寸！

“C”卡尺	“P”塞规	“M”千分尺	“H”高度计	“MS”工显或影像仪	“GE”齿轮啮合仪	“GM”齿轮检测中心	“CM”三次元	“其他”其他重检项目	序号	日期	变更内容	修改者
									16-04-07	追加刻印要求		陶政邦

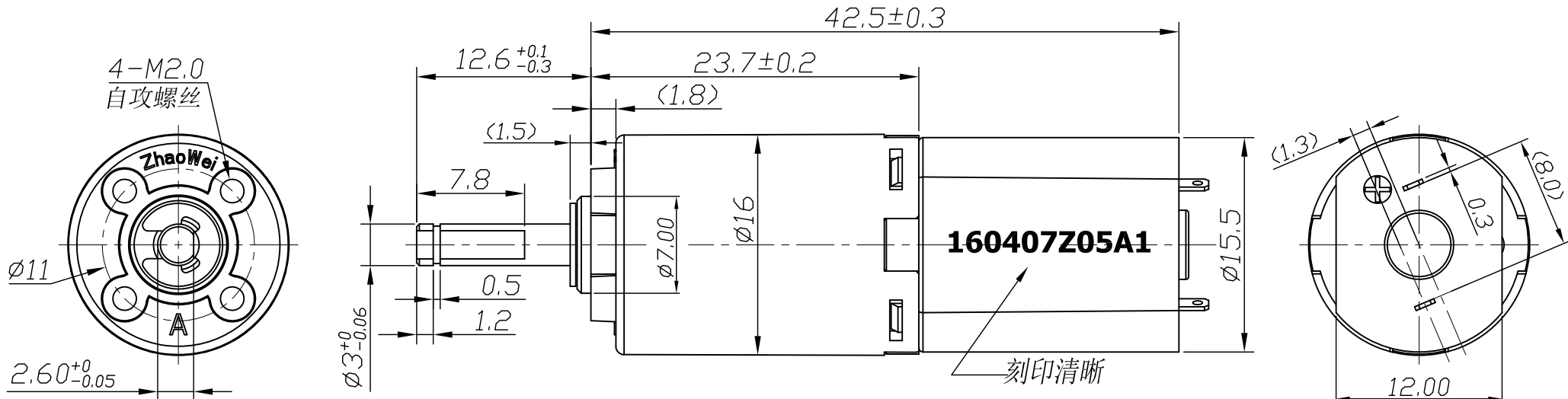

160407Z05A1

年 / 月 / 日 / 线别 / 班别
 组装车间

GEAR MOTOR DATA:

1	Rated Voltage	6.0 VDC	2	No Load Current	150mA MAX
3	No Load Speed	7.5 ± 15% rpm	4	Rated Torque	1200gf.cm
5	Rated Current	0.3A MAX	6	Rated Speed	6.5 ± 15% rpm
7	Stall Torque	5000gf.cm	8	Stall Current	0.6A MAX
9	Gear Ratio	1296:1	10	No Load Noise	62 db

Test Method: Detector with sponge to gearbox side at 10cm in ambient noise under 32dB.

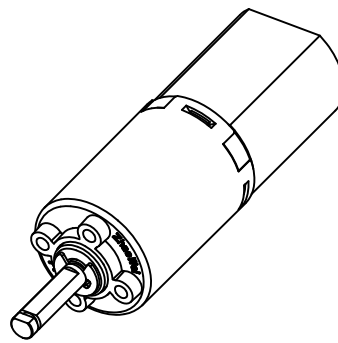

TECHNICAL REQUIREMENTS:

1. No defects such as crack, scratch, burr and deformation.
2. Dimensions in bracket for reference.
3. No abnormal noise in testing.
4. RoHS compliant.

客户编码: 310624

产品名称	φ16行星齿轮箱	未注公差	产品代码	ZWP016016-1296-02																									
客户代码	784	<table border="1"> <tr> <th colspan="3">TOLERANCE TABLE (mm)</th> </tr> <tr> <th></th> <th>IT 11</th> <th>IT 12</th> </tr> <tr> <td>0-3</td> <td>0.06</td> <td>0.10</td> </tr> <tr> <td>3-6</td> <td>0.075</td> <td>0.12</td> </tr> <tr> <td>6-10</td> <td>0.09</td> <td>0.15</td> </tr> <tr> <td>10-18</td> <td>0.11</td> <td>0.18</td> </tr> <tr> <td>18-30</td> <td>0.13</td> <td>0.21</td> </tr> <tr> <td>30-50</td> <td>0.16</td> <td>0.25</td> </tr> </table>	TOLERANCE TABLE (mm)				IT 11	IT 12	0-3	0.06	0.10	3-6	0.075	0.12	6-10	0.09	0.15	10-18	0.11	0.18	18-30	0.13	0.21	30-50	0.16	0.25	共 1 张	版本	B
TOLERANCE TABLE (mm)																													
	IT 11	IT 12																											
0-3	0.06	0.10																											
3-6	0.075	0.12																											
6-10	0.09	0.15																											
10-18	0.11	0.18																											
18-30	0.13	0.21																											
30-50	0.16	0.25																											
设计	陶政邦 2015-07-13		第 1 张	比例	1:1																								
审核		符合《ROHS相关禁止物质标准》																											
批准		ZHAOWEI 兆威																											